



SPECIFICATION FOR TFT LCD MODULE

CUSTOMER : _____

CUSTOMER MODULE : _____

HG MODEL : HG024QV021

Preliminary Specification

Final Specification

Customer Confirmation column:

Approved by : _____ Dept. : _____ Data : _____

Please return one of the copies of the specification with your signature to us within two weeks after you receive this document. If it is not returned, we will assume that you agree to the entire contents of this specification document.

Designed by	Checked by	Approved by



Contents

1. Block Diagram	5
2. Outline dimension	6
3. Input terminal Pin Assignment	7
4. LCD Optical Characteristics	9
4.1 Optical specification	9
5. Electrical Characteristics	13
5.1 Absolute Maximum Rating (Ta=25 VSS=0V)	13
5.2 DC Electrical Characteristics	13
5.3 LED Backlight Characteristics	14
6. AC Characteristic	16
6.1 8080 Series MCU Parallel Interface Characteristics: 18/16/9/8-bit Bus	16
6.2 Serial Interface Characteristics (3-line serial)	19
6.3 Serial Interface Characteristics (4-line serial)	20
6.4 RGB Interface Characteristics	21
6.5 Reset Timing	23
7. LCD Module Out-Going Quality Level	25
7.1 VISUAL & FUNCTION INSPECTION STANDARD	25
7.1.1 Inspection conditions	25
7.1.2 Definition	25
7.1.3 Sampling Plan	26
7.1.4 Criteria (Visual)	27
8. Reliability Test Result	32
Remark:	32
9. Cautions and Handling Precautions	33
9.1 Handling and Operating the Module	33
9.2 Storage and Transportation	33
10. Packing	34

Shenzhen Hongguang Display Co., Ltd

* Description

This is a color active matrix TFT (Thin Film Transistor) LCD (liquid crystal display) that uses amorphous silicon TFT as a switching device. This model is composed of a Transmissive type TFT-LCD Panel, driver circuit, back-light unit. The resolution of a 2.4'TFT-LCD contains 240X320 pixels, and can display up to 65K/262K colors.

* Features

- Low Input Voltage: 3.3V (TYP)
- Display Colors of TFT LCD: 65K/262K colors
- TFT Interface: 8/9/16/18Bit MCU Interface
3/4SPI+16/18Bit RGB Interface
3-line/4-line Serial Interface

General Information Items	Specification	Unit	Note
	Main Panel		
Display area(AA)	36.72(H) *48.96(V) (2.4inch)	mm	-
Driver element	TFT active matrix	-	-
Display colors	65K/262K	colors	-
Number of pixels	240(RGB)*320	dots	-
TFT Pixel arrangement	RGB vertical stripe	-	-
Pixel pitch	0.153 (H) x 0.153 (V)	mm	-
Viewing angle	SUPER WIDE	o'clock	-
TFT Controller IC	ST7789V	-	-
Display mode	Transflective /Normally Black VA	-	-
Operating temperature	-20~+70	°C	-
Storage temperature	-30~+80	°C	-

* Mechanical Informations

Item		Min.	Typ.	Max.	Unit	Note
Module size	Horizontal(H)		42.92		mm	-
	Vertical(V)		60.26		mm	-
	Depth(D)		2.45		mm	-
Weight			14		g	-

1. Block Diagram

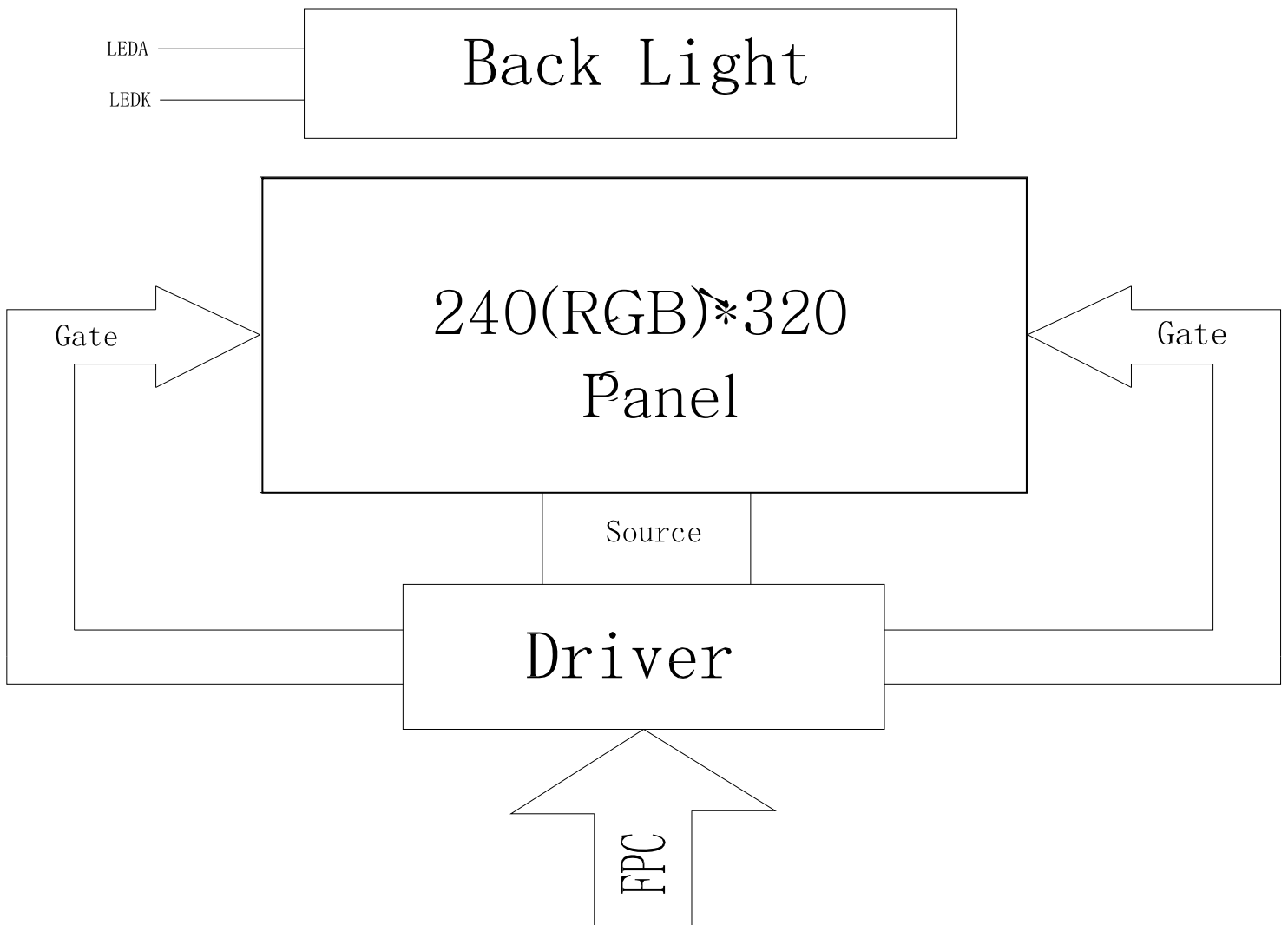



2. Outline dimension

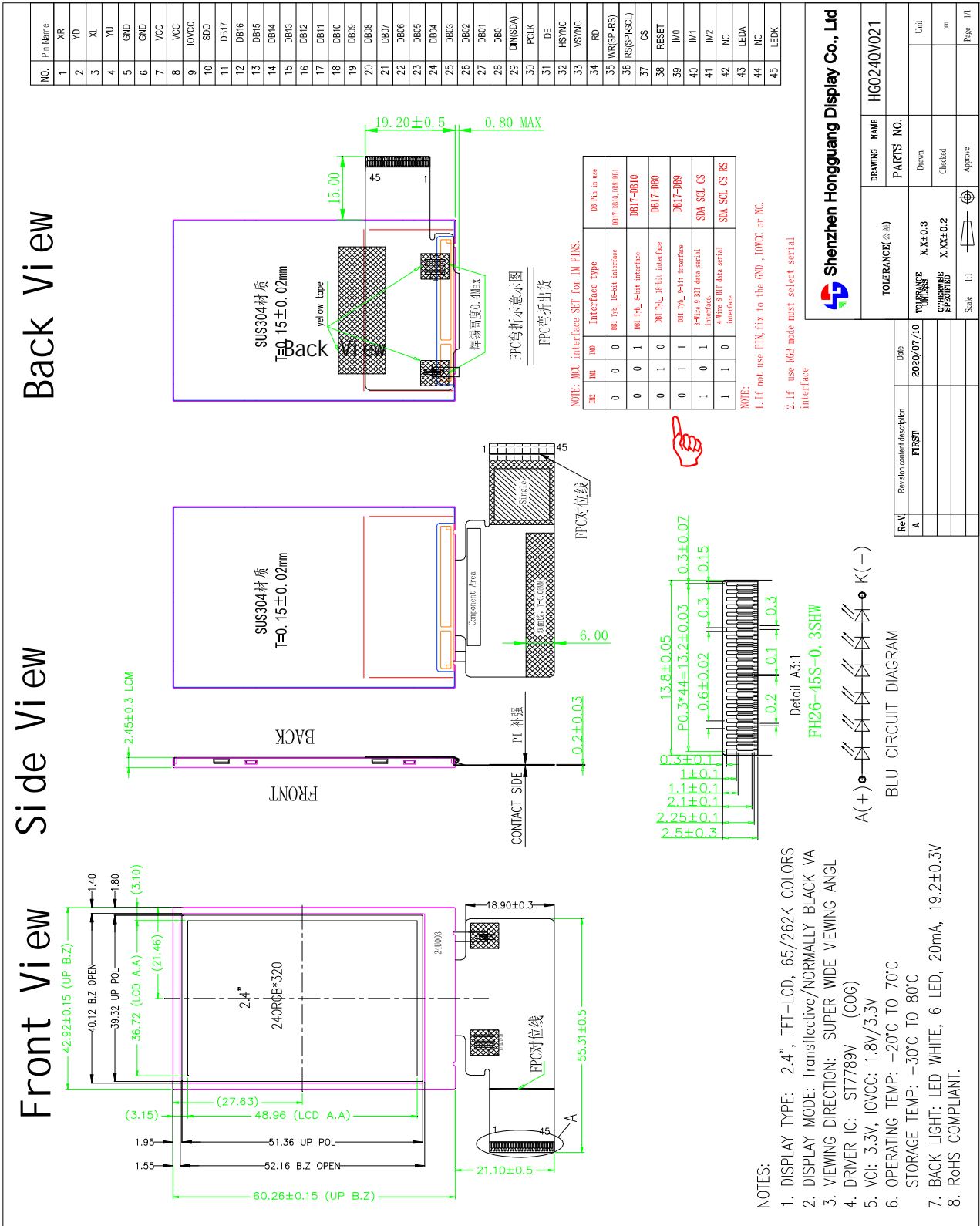

3. Input terminal Pin Assignment

NO.	SYMBOL	DISCRIPTION	I/O
1	XR	Touch panel Right Glass Terminal	A/D
2	YD	Touch panel Bottom Film Terminal	A/D
3	XL	Touch panel LIFT Glass Terminal	A/D
4	YU	Touch panel Top Film Terminal	A/D
5	GND	Ground.	P
6	GND	Ground.	P
7	VCC	Supply voltage(3.3V).	I
8	VCC	Supply voltage(3.3V).	I
9	IOVCC	Power Supply for I/O System.	I
10	SDO	SPI interface output pin. -The data is output on the falling edge of the SCL signal. -If not used, let this pin open.	O
11-28	DB17-DB0	18-bit parallel bi-directional data bus for MCU system and RGB interface mode. Fix to GND level when not in use	I/O
29	DIN(SDA)	Serial input signal. The data is latched on the rising edge of the SCL signal. fix this pin at IOVCC or GND when not in use.	I/O
30	PCLK	Dot clock signal for RGB interface operation. Fix this pin at IOVCC or GND when not in use.	I
31	DE	Data enable signal for RGB interface operation. fix this pin at IOVCC or GND when not in use.	I
32	HSYNC	Line synchronizing signal for RGB interface operation. fix this pin at IOVCC or GND when not in use.	I
33	VSYNC	Frame synchronizing signal for RGB interface operation. fix this pin at IOVCC or GND when not in use.	I
34	RD	Read enable in 8080 MCU parallel interface. -If not used, please fix this pin at IOVCC or DGND.	I
35	WR(SPI-RS)	-Write enable in MCU parallel interface. - Display data/command selection pin in 4-line serial interface. - Second Data lane in 2 data lane serial interface.	I

Shenzhen Hongguang Display Co., Ltd

		-If not used, please fix this pin at IOVCC or DGND.	
36	RS(SPI-SCL)	-Display data/command selection pin in parallel interface. -This pin is used to be serial interface clock. RS='1': display data or parameter. RS='0': command data. -If not used, please fix this pin at IOVCC or DGND.	I
37	CS	Chip select input pin ("Low" enable). fix this pin at IOVCC or GND when not in use.	I
38	RESET	This signal will reset the device and must be applied to properly initialize the chip.	I
39	IM0	18-bit parallel bi-directional data bus for MCU system and RGB interface mode. Fix to GND level when not in use	I
40	IM1		
41	IM2		
42	NC	--	--
43	LEDA	Anode pin of backlight	P
44	NC	--	--
45	LEDK	Cathode pin OF backlight	P



4. LCD Optical Characteristics

4.1 Optical specification

Item	Symbol	Condition	Min.	Typ.	Max.	Unit.	Note
Contrast Ratio	CR	$\Theta=0$	--	300	--		(1)(2)
Response time	Rising	Normal viewing angle	--	25	50	msec	(1)(3)
	Falling						
Color gamut	S(%)			60		%	(1)
Color Filter Chromaticity	White	W_X	0.241	0.281	0.321		(1)(4)
		W_Y	0.268	0.308	0.348		
	Red	R_X	0.403	0.443	0.483		
		R_Y	0.275	0.315	0.355		
	Green	G_X	0.270	0.310	0.350		
		G_Y	0.461	0.501	0.541		
	Blue	B_X	0.132	0.172	0.212		
		B_Y	0.087	0.127	0.167		
Viewing angle	Hor.	Θ_L	60	80	--		(1)(4)
		Θ_R	60	80	--		
	Ver.	Θ_U	60	80	--		
		Θ_D	60	80	--		
Option View Direction	SUPER WIDE						(5)



[1] Transmittance (T%)

The transmittance of the panel including polarizers is measured with electrical driving.

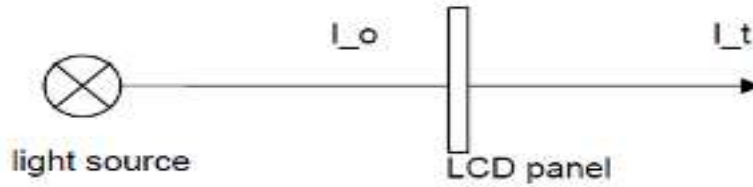

The Transmittance is defined as:

$$Tr = \frac{I_t}{I_o} \times 100\%$$

here,

I_o : the brightness of the light source.

I_t : the brightness after panel transmission.

[2] Response Time(T_r , T_f)

The rise time ' T_r ' is defined as the time for luminance to change from 90% to 10% as a result of a change of the electrical condition. The fall time ' T_f ' is defined as the time for luminance to change from 10% to 90% as a result of a change of the electrical condition.

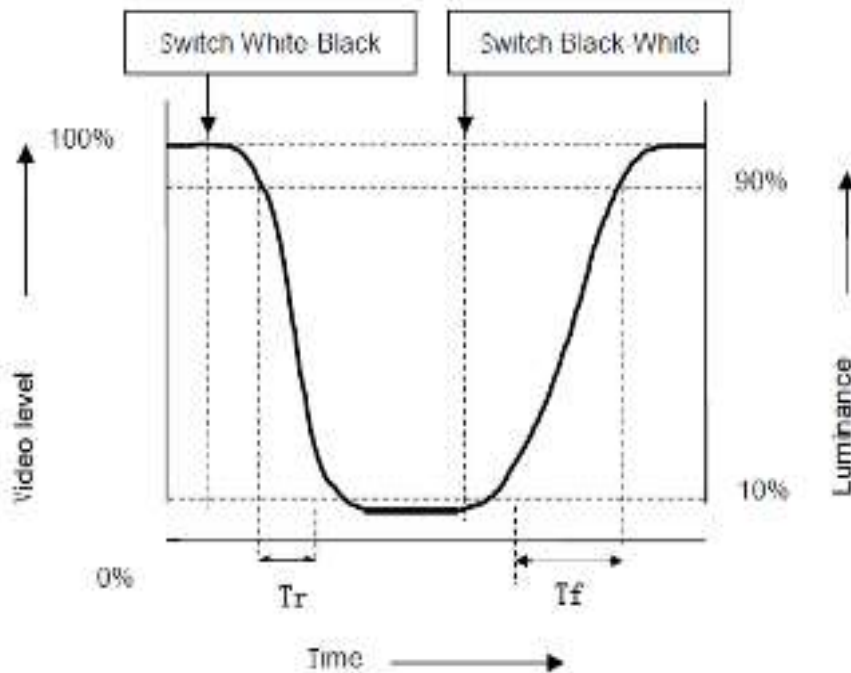



[3] Contrast ratio (Cr)

The contrast ratio (Cr), measured on a module, is the ratio between the luminance (L_w) in a full white area (R-G-B=1) and the luminance (L_d) in a dark area (R-G-B=0);

$$Cr = \frac{L_w}{L_d}$$

[4] Viewing angle diagram

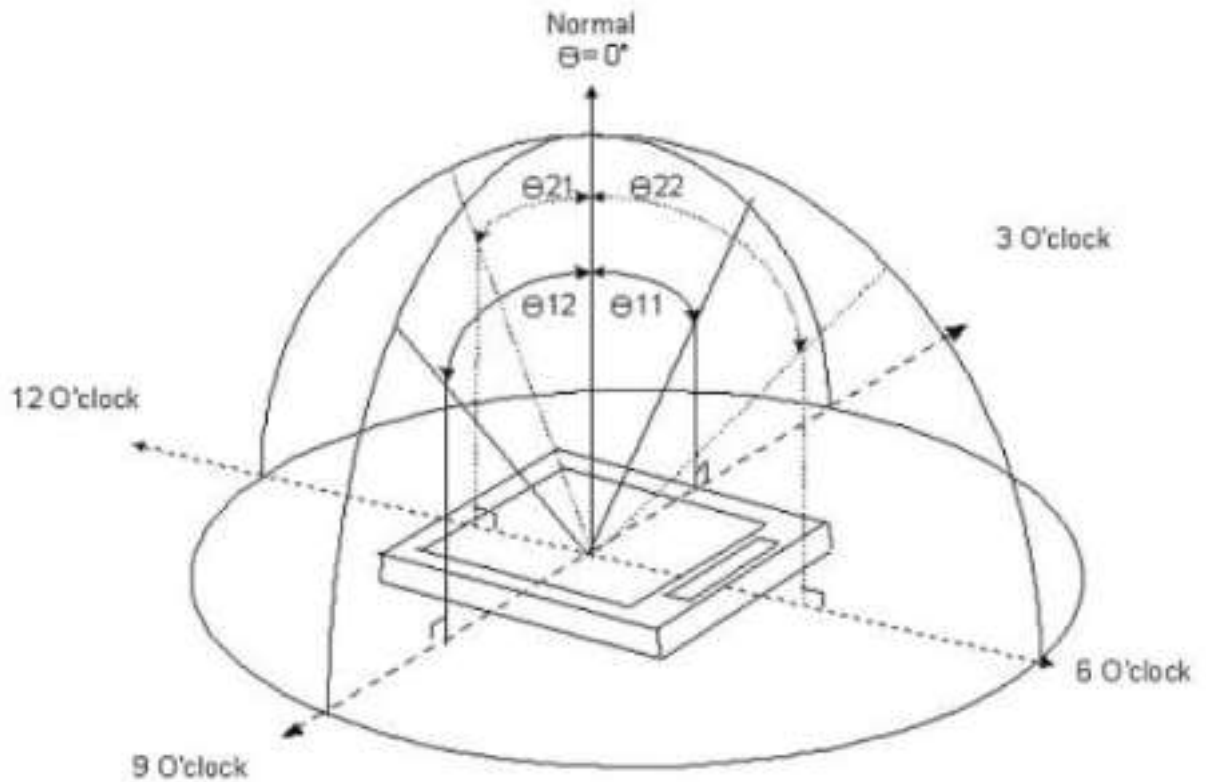



[5] Definition of color gamut

Measuring machine: CFT-01. NTSC'S Primaries: R(x,y,Y), G(x,y,Y), B(x,y,Y).

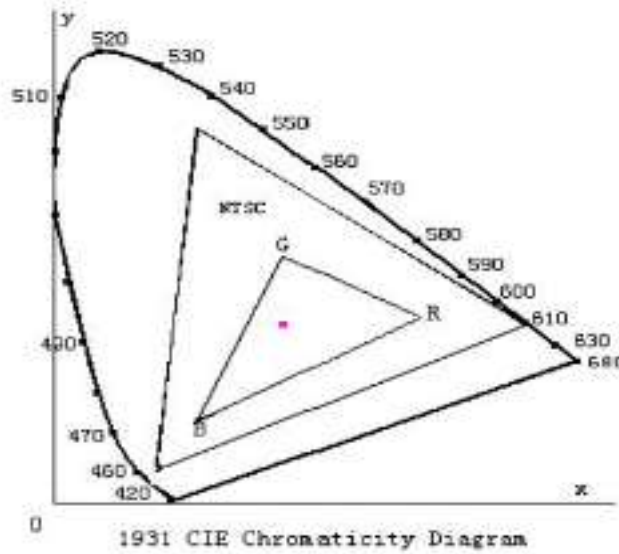

Fig. 1931 CIE chromaticity diagram

$$\text{Color gamut: } S = \frac{\text{Area of RGB triangle}}{\text{Area of NTSC triangle}} \times 100\%$$

5. Electrical Characteristics

5.1 Absolute Maximum Rating (Ta=25 VSS=0V)

Characteristics	Symbol	Min.	Max.	Unit
Digital Supply Voltage	VCC	-0.3	4.6	V
Supply Voltage (Logic)	IOVCC	-0.3	4.6	
Operating temperature	T _{OP}	-20	+70	°C
Storage temperature	T _{ST}	-30	+80	°C

NOTE: If the absolute maximum rating of even is one of the above parameters is exceeded even momentarily, the quality of the product may be degraded. Absolute maximum ratings, therefore, specify the values exceeding which the product may be physically damaged. Be sure to use the product within the range of the absolute maximum ratings.

5.2 DC Electrical Characteristics

Characteristics	Symbol	Min.	Typ.	Max.	Unit	Note
Digital Supply Voltage	VCC	2.4	3.3	3.6	V	
Supply Voltage (Logic)	IOVCC	1.65	1.8	3.3		
Normal mode Current consumption	IDD	--	7.3	--	mA	
Level input voltage	V _{IH}	0.7 Iovcc		Iovcc	V	
	V _{IL}	GND		0.3Iovcc	V	
Level output voltage	V _{OH}	0.8 Iovcc		Iovcc	V	
	V _{OL}	GND		0.2 Iovcc	V	

5.3 LED Backlight Characteristics

The back-light system is edge-lighting type with 6 chips White LED

Item	Symbol	Min.	Typ.	Max.	Unit	Note
Forward Current	I_F	15	20	--	mA	
Forward Voltage	V_F	--	19.2	--	V	
LCM Luminance	L_v	310	360	--	cd/m ²	Note3
LED life time	Hr	50000	--	--	Hour	Note1,2
Uniformity	AVg	80	--	--	%	Note3

SNote (1) LED life time (Hr) can be defined as the time in which it continues to operate under the condition:

$T_a=25\pm 3\text{ }^\circ\text{C}$, typical IL value indicated in the above table until the brightness becomes less than 50%.

Note (2) The "LED life time" is defined as the module brightness decrease to 50% original brightness at $T_a=25\text{ }^\circ\text{C}$ and $I_L=20\text{mA}$. The LED lifetime could be decreased if operating I_L is larger than 20mA. The constant current driving method is suggested.

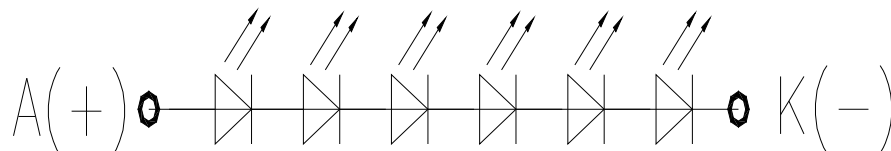

BLU CIRCUIT DIAGRAM



NOTE 3: Luminance Uniformity of these 9 points is defined as below:

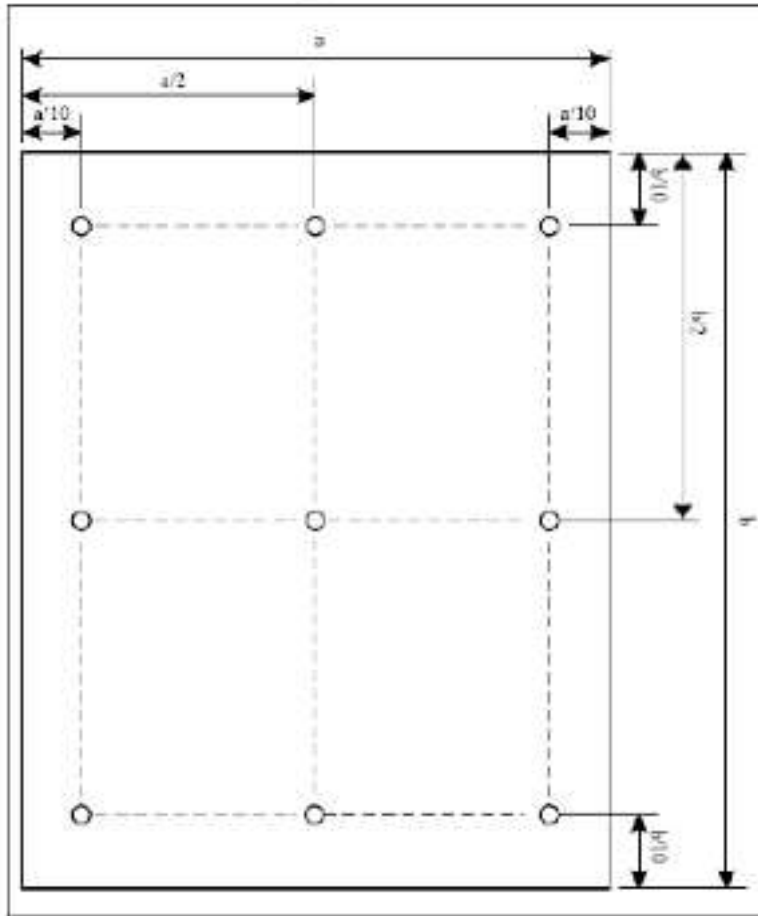

$$\text{Uniformity} = \frac{\text{minimum luminance in 9 points (1-9)}}{\text{maximum luminance in 9 points (1-9)}}$$

$$\text{Luminance} = \frac{\text{Total Luminance of 9 points}}{9}$$



6. AC Characteristic

6.1 8080 Series MCU Parallel Interface Characteristics: 18/16/9/8-bit Bus

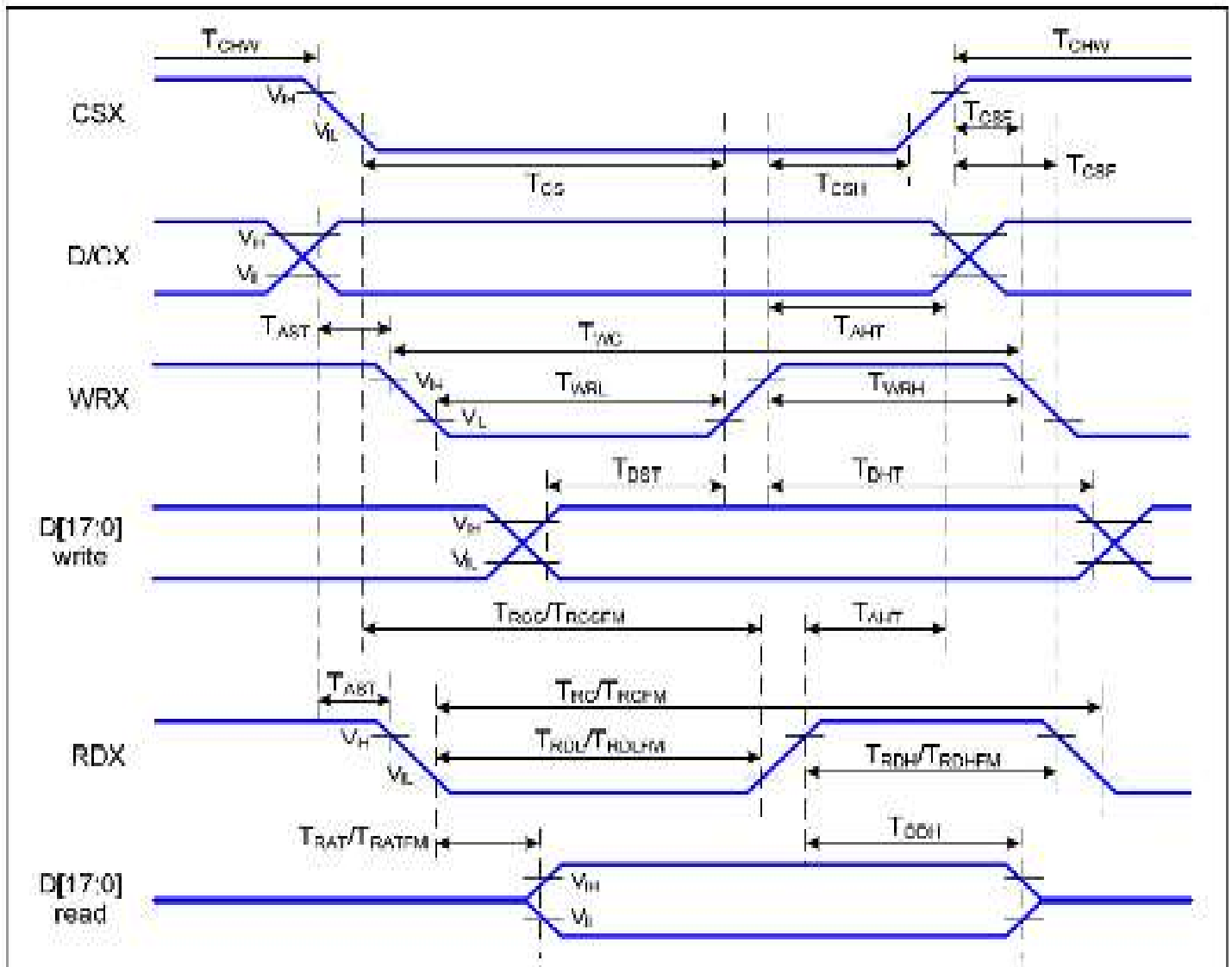

Figure 1 Parallel Interface Timing Characteristics (8080-Series MCU Interface)



VDDI=1.65 to 3.3V, VDD=2.4 to 3.3V, AGND=DGND=0V, Ta=25℃

Signal	Symbol	Parameter	Min	Max	Unit	Description
D/CX	T_{AST}	Address setup time	0		ns	-
	T_{AHT}	Address hold time (Write/Read)	10		ns	
CSX	T_{CHW}	Chip select "H" pulse width	0		ns	-
	T_{CS}	Chip select setup time (Write)	15		ns	
	T_{RCS}	Chip select setup time (Read ID)	45		ns	
	T_{RCSFM}	Chip select setup time (Read FM)	355		ns	
	T_{CSF}	Chip select wait time (Write/Read)	10		ns	
	T_{CSH}	Chip select hold time	10		ns	
WRX	T_{WC}	Write cycle	66		ns	
	T_{WRH}	Control pulse "H" duration	15		ns	
	T_{WRL}	Control pulse "L" duration	15		ns	
RDX (ID)	T_{RC}	Read cycle (ID)	160		ns	When read ID data
	T_{RDH}	Control pulse "H" duration (ID)	90		ns	
	T_{RDL}	Control pulse "L" duration (ID)	45		ns	
RDX (FM)	T_{RDFM}	Read cycle (FM)	450		ns	When read from frame memory
	T_{RDHFM}	Control pulse "H" duration (FM)	90		ns	
	T_{RDLFM}	Control pulse "L" duration (FM)	355		ns	
D[17:0]	T_{DST}	Data setup time	10		ns	For CL=30pF



T_{DHT}	Data hold time	10		ns
T_{RAT}	Read access time (ID)		40	ns
T_{RATFM}	Read access time (FM)		340	ns
T_{ODH}	Output disable time	20	80	ns

Table 4 8080 Parallel Interface Characteristics

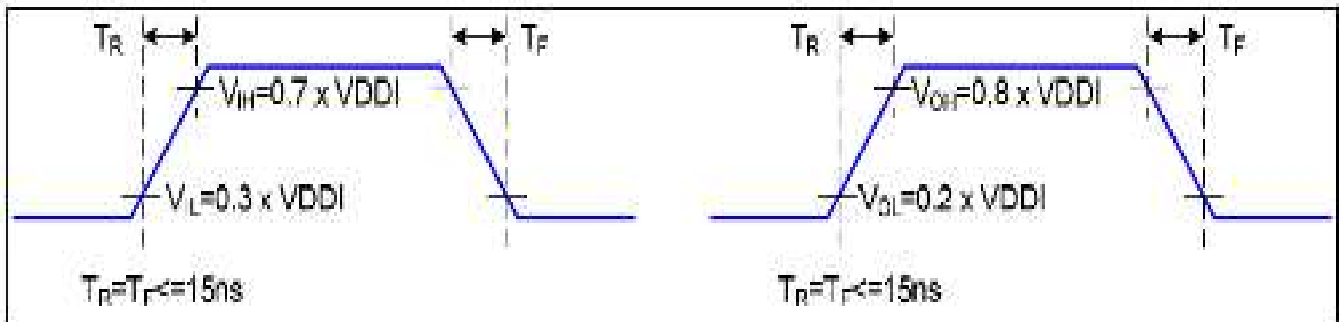

Figure 2 Rising and Falling Timing for I/O Signal

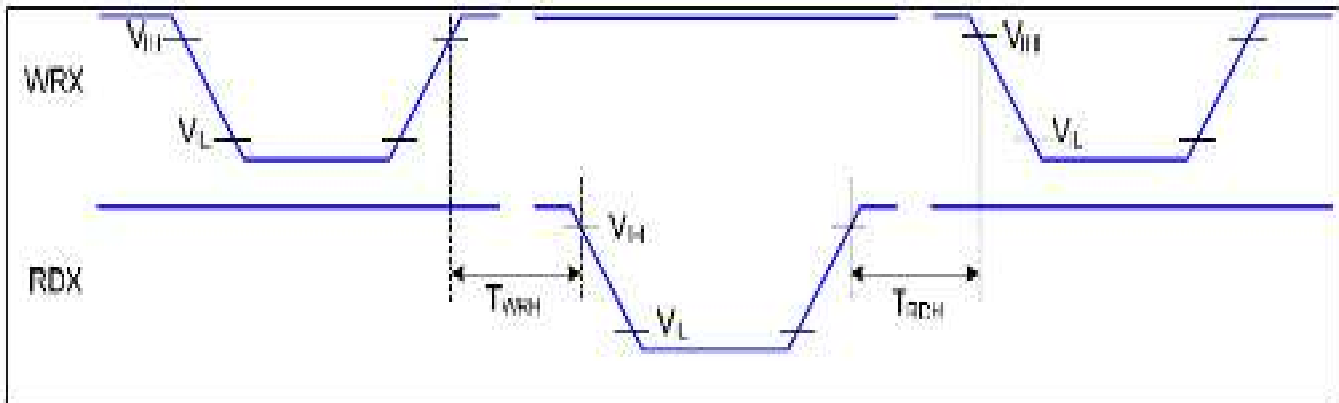

Figure 3 Write to Read and Read to Write Timing

Note: The rising time and falling time (T_r , T_f) of input signal and fall time are specified at 15 ns or less. Logic high and low levels are specified as 30% and 70% of VDDI for Input signals.



6.2 Serial Interface Characteristics (3-line serial)

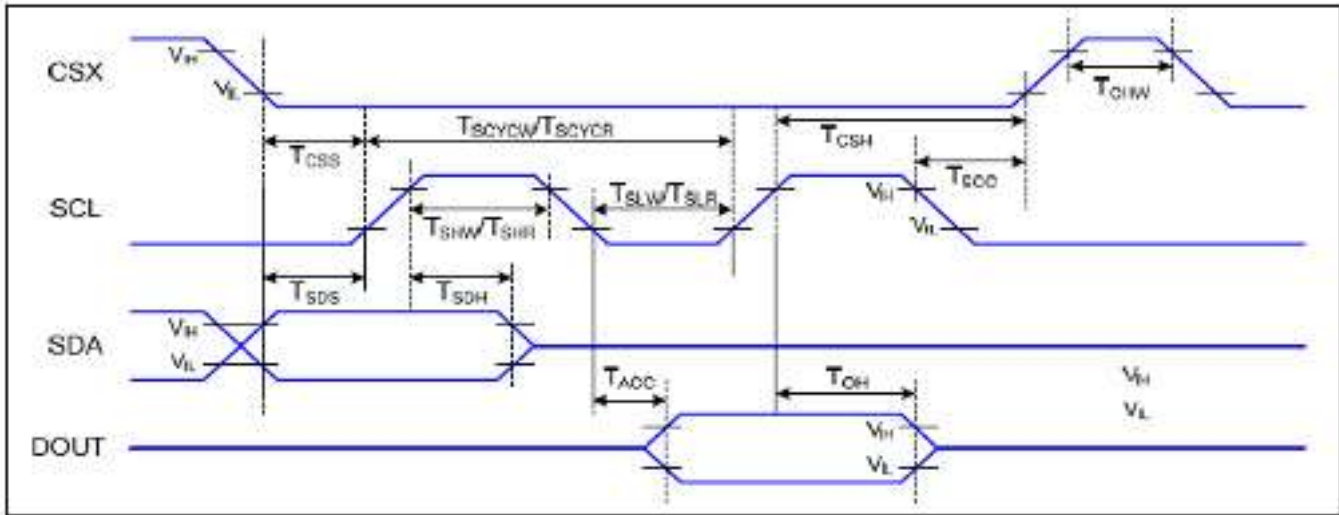

Figure 4 3-line serial Interface Timing Characteristics

VDDI=1.65 to 3.3V, VDD=2.4 to 3.3V, AGND=DGND=0V, Ta=25°C

Signal	Symbol	Parameter	Min	Max	Unit	Description
CSX	T_{CSS}	Chip select setup time (write)	15		ns	
	T_{CCH}	Chip select hold time (write)	15		ns	
	T_{CSS}	Chip select setup time (read)	60		ns	
	T_{CCH}	Chip select hold time (read)	65		ns	
	T_{CHW}	Chip select "H" pulse width	40		ns	
SCL	T_{SCYOW}	Serial clock cycle (Write)	66		ns	
	T_{SHW}	SCL "H" pulse width (Write)	15		ns	
	T_{SLW}	SCL "L" pulse width (Write)	15		ns	
	T_{SCYOR}	Serial clock cycle (Read)	150		ns	
	T_{SHR}	SCL "H" pulse width (Read)	60		ns	
	T_{SLR}	SCL "L" pulse width (Read)	60		ns	
SDA (DIN)	T_{SDS}	Data setup time	10		ns	
	T_{SDH}	Data hold time	10		ns	
DOUT	T_{ACC}	Access time	10	50	ns	For maximum CL=30pF
	T_{OH}	Output disable time	15	50	ns	For minimum CL=8pF

Table 5 3-line serial Interface Characteristics

Note : The rising time and falling time (T_r , T_f) of Input signal are specified at 15 ns or less. Logic high and low levels are specified as 30% and 70% of VDDI for Input signals.



6.3 Serial Interface Characteristics (4-line serial)

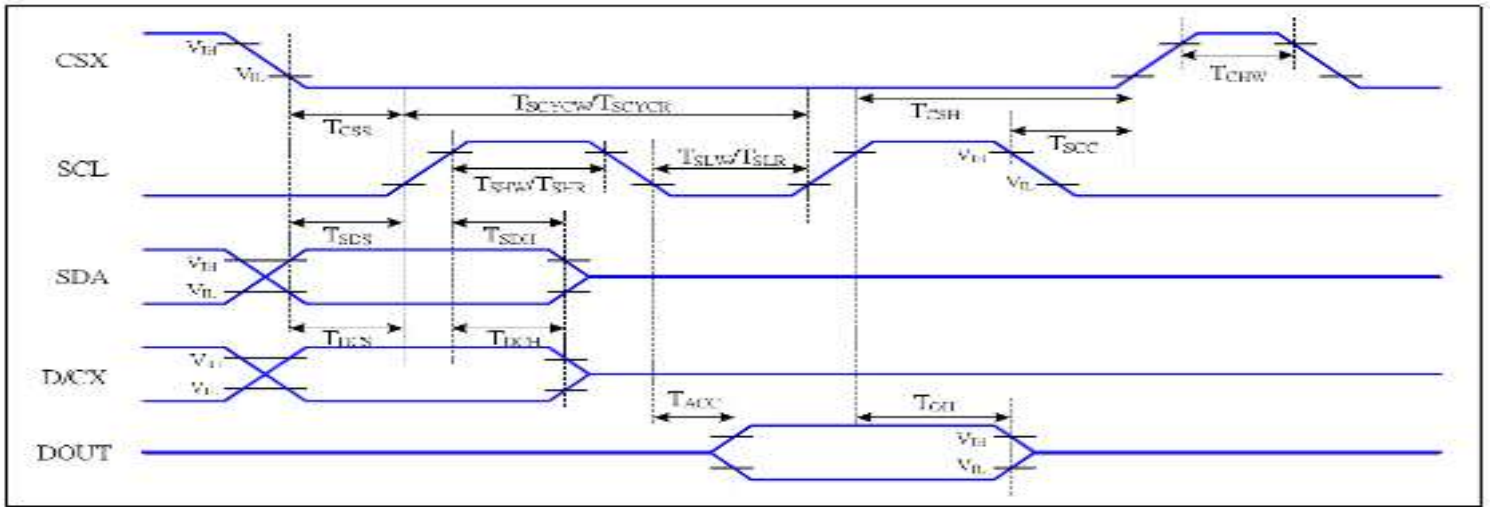

Figure 5 4-line serial Interface Timing Characteristics

VDDI=1.65 to 3.3V, VDD=2.4 to 3.3V, AGND=DGND=0V, Ta=25°C

Signal	Symbol	Parameter	MIN	MAX	Unit	Description
CSX	T_{CSS}	Chip select setup time (write)	15		ns	
	T_{CSH}	Chip select hold time (write)	15		ns	
	T_{CSS}	Chip select setup time (read)	60		ns	
	T_{SCC}	Chip select hold time (read)	65		ns	
	T_{CHW}	Chip select "H" pulse width	40		ns	
SCL	T_{SCYCW}	Serial clock cycle (Write)	66		ns	-write command & data ram
	T_{SHW}	SCL "H" pulse width (Write)	15		ns	
	T_{SLW}	SCL "L" pulse width (Write)	15		ns	
	T_{SCYCR}	Serial clock cycle (Read)	150		ns	-read command & data ram
	T_{SHR}	SCL "H" pulse width (Read)	60		ns	
	T_{SLR}	SCL "L" pulse width (Read)	60		ns	
D/CX	T_{DCS}	D/CX setup time	10		ns	
	T_{DCH}	D/CX hold time	10		ns	
SDA (DIN)	T_{SDS}	Data setup time	10		ns	
	T_{SDH}	Data hold time	10		ns	
DOUT	T_{ACC}	Access time	10	50	ns	For maximum CL=30pF
	T_{OH}	Output disable time	15	50	ns	For minimum CL=8pF

Table 6 4 line serial Interface Characteristics

Note : The rising time and falling time (T_r , T_f) of input signal are specified at 15 ns or less. Logic high and low levels are specified as



6.4 RGB Interface Characteristics

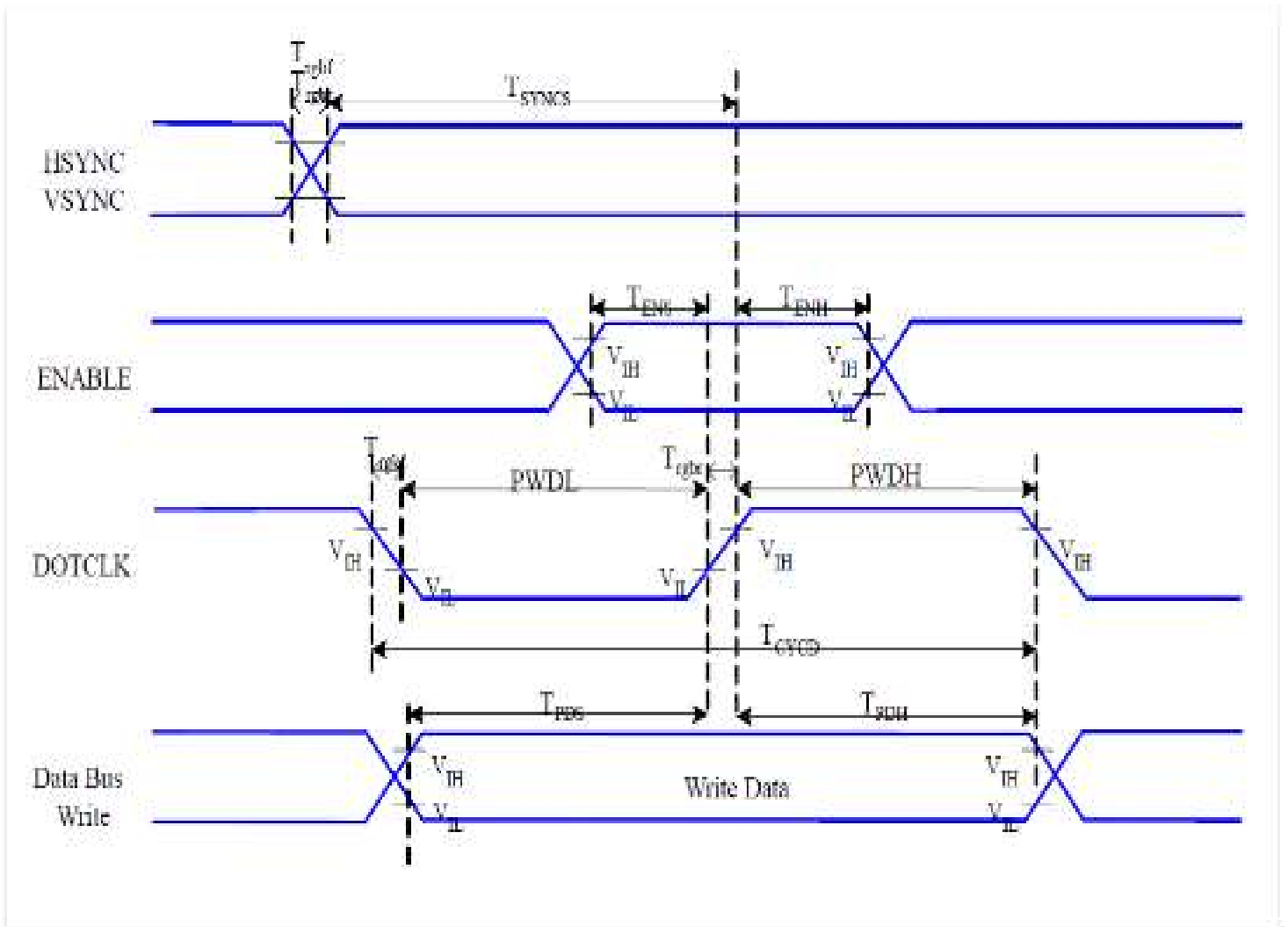

Figure 6 RGB Interface Timing Characteristics



VDDI=1.65 to 3.3V, VDD=2.4 to 3.3V, AGND=DGND=0V, Ta=25 °C

Signal	Symbol	Parameter	MIN	MAX	Unit	Description
HSYNC, VSYNC	T_{SYNCS}	VSYNC, HSYNC Setup Time	30	-	ns	
ENABLE	T_{ENS}	Enable Setup Time	25	-	ns	
	T_{ENH}	Enable Hold Time	25	-	ns	
DOTCLK	PWDH	DOTCLK High-level Pulse Width	60	-	ns	
	PWDL	DOTCLK Low-level Pulse Width	60	-	ns	
	T_{CYCD}	DOTCLK Cycle Time	120	-	ns	
	Trghr, Trghf	DOTCLK Rise/Fall time	-	20	ns	
DB	T_{PDS}	PD Data Setup Time	50	-	ns	
	T_{PDH}	PD Data Hold Time	50	-	ns	

Table 7 18/16 Bits RGB Interface Timing Characteristics

Signal	Symbol	Parameter	MIN	MAX	Unit	Description
HSYNC, VSYNC	T_{SYNCS}	VSYNC, HSYNC Setup Time	25	-	ns	
ENABLE	T_{ENS}	Enable Setup Time	25	-	ns	

Sitronix Confidential The information contained herein is the exclusive property of Sitronix and shall not be distributed, reproduced, or disclosed in whole or in part without prior written permission of Sitronix.

	T_{ENH}	Enable Hold Time	25	-	ns	
DOTCLK	PWDH	DOTCLK High-level Pulse Width	25	-	ns	
	PWDL	DOTCLK Low-level Pulse Width	25	-	ns	
	T_{CYCD}	DOTCLK Cycle Time	55	-	ns	
	Trghr, Trghf	DOTCLK Rise/Fall time	-	10	ns	
DB	T_{PDS}	PD Data Setup Time	25	-	ns	
	T_{PDH}	PD Data Hold Time	25	-	ns	

Table 8 6 Bits RGB Interface Timing Characteristics

6.5 Reset Timing

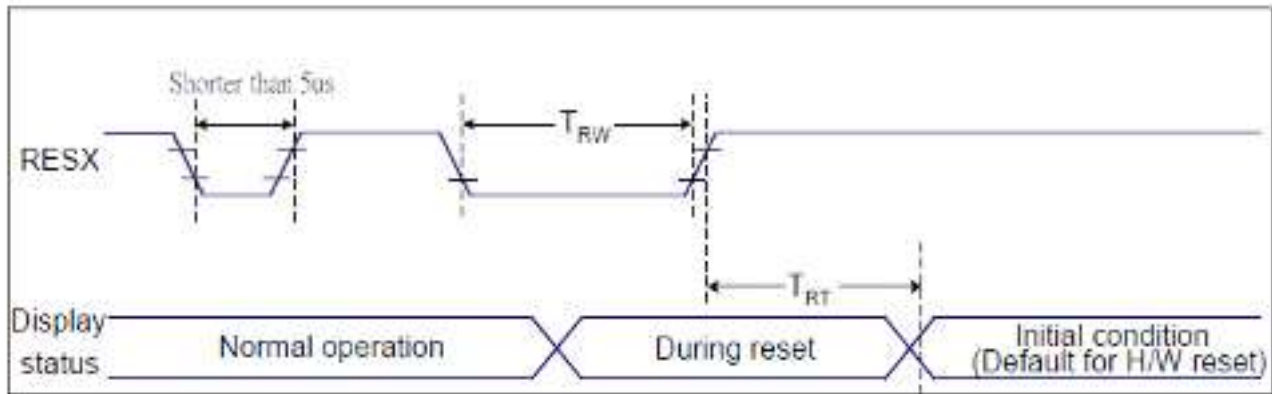

Figure 7 Reset Timing

VDDI=1.65 to 3.3V, VDD=2.4 to 3.3V, AGND=DGND=0V, Ta=25 °C

Related Pins	Symbol	Parameter	MIN	MAX	Unit
RESX	TRW	Reset pulse duration	10	-	us
	TRT	Reset cancel	-	5 (Note 1, 5)	ms
				120 (Note 1, 6, 7)	ms

Table 9 Reset Timing

Notes:

1. The reset cancel includes also required time for loading ID bytes, VCOM setting and other settings from NVM (or similar device) to registers. This loading is done every time when there is HW reset cancel time (TRT) within 5 ms after a rising edge of RESX.

2. Spike due to an electrostatic discharge on RESX line does not cause irregular system reset according to the table below:

RESX Pulse	Action
Shorter than 5us	Reset Rejected
Longer than 9us	Reset
Between 5us and 9us	Reset starts

3. During the Resetting period, the display will be blanked (The display is entering blanking sequence, which maximum time is 120 ms, when Reset Starts in Sleep Out-mode. The display remains the blank state in Sleep In-mode.) and then return to Default condition for Hardware Reset.

4. Spike Rejection also applies during a valid reset pulse as shown below:

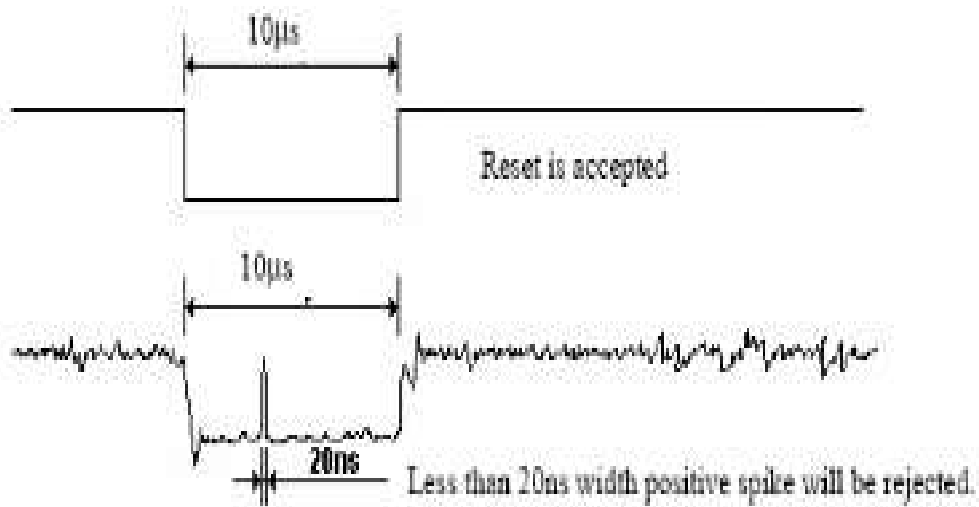

5. When *Reset* applied during *Sleep In Mode*.

6. When *Reset* applied during *Sleep Out Mode*.

7. It is necessary to wait 5msec after releasing *RESX* before sending commands. Also *Sleep Out* command cannot be sent for 120msec.



7. LCD Module Out-Going Quality Level

7.1 VISUAL & FUNCTION INSPECTION STANDARD

7.1.1 Inspection conditions

Inspection performed under the following conditions is recommended.

Temperature : $25\pm 5^{\circ}\text{C}$

Humidity : $65\%\pm 10\%\text{RH}$

Viewing Angle : Normal viewing Angle.

Illumination: Single fluorescent lamp (300 to 700Lux)

Viewing distance:30-50cm

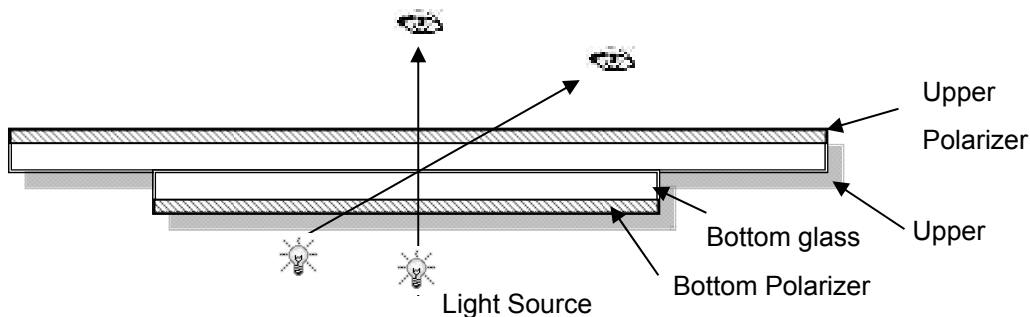

7.1.2 Definition

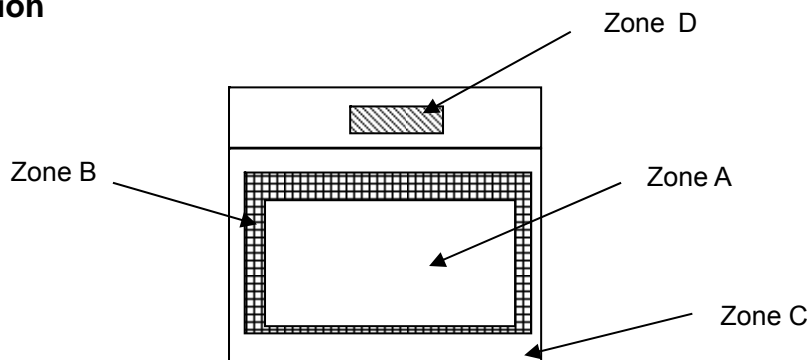

Zone A : Effective Viewing Area(Character or Digit can be seen)

Zone B : Viewing Area except Zone A

Zone C : Outside (Zone A+Zone B) which can not be seen after assembly by customer .)

Zone D : IC Bonding Area

Note:

As a general rule ,visual defects in Zone C can be ignored when it doesn't effect product function or appearance after assembly by customer

Shenzhen Hongguang Display Co., Ltd

7.1.3 Sampling Plan

According to GB/T 2828-2003 ; , normal inspection, Class II

AQL:

Major defect	Minor defect
0.65	1.5

LCD: Liquid Crystal Display , TP: Touch Panel , LCM: Liquid Crystal Module

No	Items to be inspected	Criteria	Classification of defects
1	Functional defects	1) No display, Open or miss line 2) Display abnormally, Short 3) Backlight no lighting, abnormal lighting. 4) TP no function	Major
2	Missing	Missing component	
3	Outline dimension	Overall outline dimension beyond the drawing is not allowed	
4	Color tone	Color unevenness, refer to limited sample	Minor
5	Spot Line defect	Light dot, Dim spot, Polarizer Bubble ; Polarizer accidented spot.	
6	Soldering appearance	Good soldering , Peeling off is not allowed.	
7	LCD/Polarizer/TP	Black/White spot/line, scratch, crack, etc.	

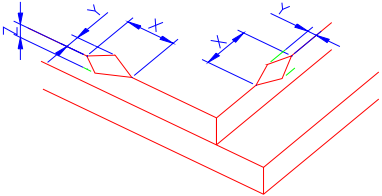
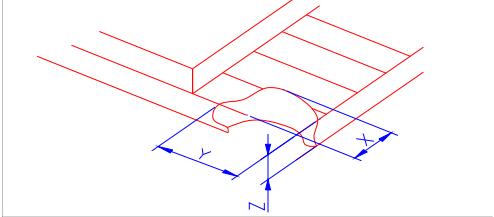
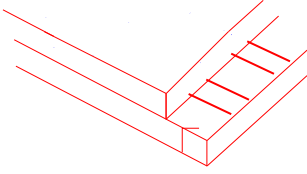

7.1.4 Criteria (Visual)

Number	Items	Criteria(mm)						
1.0 LCD Crack/Broken NOTE: X: Length Y: Width Z: Height L: Length of ITO, T: Height of LCD	(1) The edge of LCD broken	 <table border="1" data-bbox="756 667 1455 815"> <thead> <tr> <th>X</th> <th>Y</th> <th>Z</th> </tr> </thead> <tbody> <tr> <td>≤3.0mm</td> <td><Inner border line of the seal</td> <td>≤T</td> </tr> </tbody> </table>	X	Y	Z	≤3.0mm	<Inner border line of the seal	≤T
X	Y	Z						
≤3.0mm	<Inner border line of the seal	≤T						
	(2)LCD corner broken	 <table border="1" data-bbox="836 1122 1375 1218"> <thead> <tr> <th>X</th> <th>Y</th> <th>Z</th> </tr> </thead> <tbody> <tr> <td>≤3.0mm</td> <td>≤L</td> <td>≤T</td> </tr> </tbody> </table>	X	Y	Z	≤3.0mm	≤L	≤T
X	Y	Z						
≤3.0mm	≤L	≤T						
	(3) LCD crack	 <p style="text-align: center;">Crack Not allowed</p>						

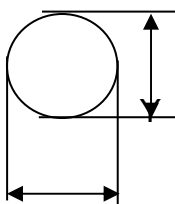

2.0	Spot defect	① light dot (LCD/TP/Polarizer black/white spot , light dot, pinhole, dent, stain)																									
		<table border="1" style="width: 100%; border-collapse: collapse;"> <thead> <tr> <th rowspan="2" style="text-align: center;">Zone Size (mm)</th> <th colspan="3" style="text-align: center;">Acceptable Qty</th> </tr> <tr> <th style="text-align: center;">A</th> <th style="text-align: center;">B</th> <th style="text-align: center;">C</th> </tr> </thead> <tbody> <tr> <td style="text-align: center;">$\Phi \leq 0.10$</td> <td colspan="3" style="text-align: center;">Ignore</td> </tr> <tr> <td style="text-align: center;">$0.10 < \Phi \leq 0.20$</td> <td colspan="3" style="text-align: center;">3(distance $\geq 10\text{mm}$)</td> </tr> <tr> <td style="text-align: center;">$0.20 < \Phi \leq 0.25$</td> <td colspan="3" style="text-align: center;">2</td> </tr> <tr> <td style="text-align: center;">$\Phi > 0.3$</td> <td colspan="3" style="text-align: center;">0</td> </tr> </tbody> </table>			Zone Size (mm)	Acceptable Qty			A	B	C	$\Phi \leq 0.10$	Ignore			$0.10 < \Phi \leq 0.20$	3(distance $\geq 10\text{mm}$)			$0.20 < \Phi \leq 0.25$	2			$\Phi > 0.3$	0		
	Zone Size (mm)	Acceptable Qty																									
		A	B	C																							
	$\Phi \leq 0.10$	Ignore																									
$0.10 < \Phi \leq 0.20$	3(distance $\geq 10\text{mm}$)																										
$0.20 < \Phi \leq 0.25$	2																										
$\Phi > 0.3$	0																										
X	<table border="1" style="width: 100%; border-collapse: collapse;"> <thead> <tr> <th rowspan="2" style="text-align: center;">Zone Size (mm)</th> <th colspan="3" style="text-align: center;">Acceptable Qty</th> </tr> <tr> <th style="text-align: center;">A</th> <th style="text-align: center;">B</th> <th style="text-align: center;">C</th> </tr> </thead> <tbody> <tr> <td style="text-align: center;">$\Phi \leq 0.1$</td> <td colspan="3" style="text-align: center;">Ignore</td> </tr> <tr> <td style="text-align: center;">$0.10 < \Phi \leq 0.20$</td> <td colspan="3" style="text-align: center;">3(distance $\geq 10\text{mm}$)</td> </tr> <tr> <td style="text-align: center;">$0.20 < \Phi \leq 0.25$</td> <td colspan="3" style="text-align: center;">2</td> </tr> <tr> <td style="text-align: center;">$\Phi > 0.3$</td> <td colspan="3" style="text-align: center;">0</td> </tr> </tbody> </table>			Zone Size (mm)	Acceptable Qty			A	B	C	$\Phi \leq 0.1$	Ignore			$0.10 < \Phi \leq 0.20$	3(distance $\geq 10\text{mm}$)			$0.20 < \Phi \leq 0.25$	2			$\Phi > 0.3$	0			
Zone Size (mm)					Acceptable Qty																						
				A	B	C																					
$\Phi \leq 0.1$				Ignore																							
$0.10 < \Phi \leq 0.20$	3(distance $\geq 10\text{mm}$)																										
$0.20 < \Phi \leq 0.25$	2																										
$\Phi > 0.3$	0																										
$\Phi = (X+Y)/2$	<table border="1" style="width: 100%; border-collapse: collapse;"> <thead> <tr> <th rowspan="2" style="text-align: center;">Zone Size (mm)</th> <th colspan="3" style="text-align: center;">Acceptable Qty</th> </tr> <tr> <th style="text-align: center;">A</th> <th style="text-align: center;">B</th> <th style="text-align: center;">C</th> </tr> </thead> <tbody> <tr> <td style="text-align: center;">$\Phi \leq 0.2$</td> <td colspan="3" style="text-align: center;">Ignore</td> </tr> <tr> <td style="text-align: center;">$0.3 < \Phi \leq 0.5$</td> <td colspan="3" style="text-align: center;">2(distance $\geq 10\text{mm}$)</td> </tr> <tr> <td style="text-align: center;">$\Phi > 0.5$</td> <td colspan="3" style="text-align: center;">0</td> </tr> </tbody> </table>			Zone Size (mm)	Acceptable Qty			A	B	C	$\Phi \leq 0.2$	Ignore			$0.3 < \Phi \leq 0.5$	2(distance $\geq 10\text{mm}$)			$\Phi > 0.5$	0							
Zone Size (mm)					Acceptable Qty																						
	A	B	C																								
$\Phi \leq 0.2$	Ignore																										
$0.3 < \Phi \leq 0.5$	2(distance $\geq 10\text{mm}$)																										
$\Phi > 0.5$	0																										
	<table border="1" style="width: 100%; border-collapse: collapse;"> <thead> <tr> <th rowspan="2" style="text-align: center;">Zone Size (mm)</th> <th colspan="3" style="text-align: center;">Acceptable Qty</th> </tr> <tr> <th style="text-align: center;">A</th> <th style="text-align: center;">B</th> <th style="text-align: center;">C</th> </tr> </thead> <tbody> <tr> <td style="text-align: center;">$\Phi \leq 0.1$</td> <td colspan="3" style="text-align: center;">Ignore</td> </tr> <tr> <td style="text-align: center;">$0.15 < \Phi \leq 0.2$</td> <td colspan="3" style="text-align: center;">2(distance $\geq 10\text{mm}$)</td> </tr> <tr> <td style="text-align: center;">$\Phi > 0.2$</td> <td colspan="3" style="text-align: center;">0</td> </tr> </tbody> </table>			Zone Size (mm)	Acceptable Qty			A	B	C	$\Phi \leq 0.1$	Ignore			$0.15 < \Phi \leq 0.2$	2(distance $\geq 10\text{mm}$)			$\Phi > 0.2$	0							
Zone Size (mm)	Acceptable Qty																										
	A	B	C																								
$\Phi \leq 0.1$	Ignore																										
$0.15 < \Phi \leq 0.2$	2(distance $\geq 10\text{mm}$)																										
$\Phi > 0.2$	0																										
	<table border="1" style="width: 100%; border-collapse: collapse;"> <thead> <tr> <th rowspan="2" style="text-align: center;">Zone Size (mm)</th> <th colspan="3" style="text-align: center;">Acceptable Qty</th> </tr> <tr> <th style="text-align: center;">A</th> <th style="text-align: center;">B</th> <th style="text-align: center;">C</th> </tr> </thead> <tbody> <tr> <td style="text-align: center;">$\Phi \leq 0.2$</td> <td colspan="3" style="text-align: center;">Ignore</td> </tr> <tr> <td style="text-align: center;">$0.3 < \Phi \leq 0.4$</td> <td colspan="3" style="text-align: center;">3(distance $\geq 10\text{ m}$)</td> </tr> <tr> <td style="text-align: center;">$0.4 < \Phi \leq 0.5$</td> <td colspan="3" style="text-align: center;">2</td> </tr> <tr> <td style="text-align: center;">$\Phi > 0.5$</td> <td colspan="3" style="text-align: center;">0</td> </tr> </tbody> </table>			Zone Size (mm)	Acceptable Qty			A	B	C	$\Phi \leq 0.2$	Ignore			$0.3 < \Phi \leq 0.4$	3(distance $\geq 10\text{ m}$)			$0.4 < \Phi \leq 0.5$	2			$\Phi > 0.5$	0			
Zone Size (mm)	Acceptable Qty																										
	A	B	C																								
$\Phi \leq 0.2$	Ignore																										
$0.3 < \Phi \leq 0.4$	3(distance $\geq 10\text{ m}$)																										
$0.4 < \Phi \leq 0.5$	2																										
$\Phi > 0.5$	0																										



3.0	Line defect (LCD/TP /Polarizer backlight black/white line, scratch, stain)	Width(mm)	Length(m m)	Acceptable Qty		
				A	B	C
		$\Phi \leq 0.03$	Ignore	Ignore		
		$0.03 < W \leq 0.04$	$L \leq 3.0$	$N \leq 2$		
		$0.04 < W \leq 0.05$	$L \leq 2.0$	$N \leq 1$		
	$0.05 < W$	Define as spot defect				
4.0	Electronic Comp onents SMT	Not allow missing parts, solderless connection, cold solder joint, mis match, The positive and negative polarity opposite				
5.0	Display color& B rightness	1. Color: Measuring the color coordinates, The measurement standar d according to the datasheet or samples. 2. Brightness: Measuring the brightness of White screen, The measu rement standard according to the datasheet or Samples.				
6.0	LCD Mura	By 5% ND filter invisible.				

7.0	RTP Related	TP film bubble/ accident ed spot	Size Φ (mm)	Acceptable Qty		
				A	B	C
			$\Phi \leq 0.1$	Ignore		
			$0.1 < \Phi \leq 0.2$	3 (distance ≥ 10 mm)		
			$0.25 < \Phi \leq 0.3$	2		
	$\Phi > 0.3$	0				
			Ignore			



			<table border="1"> <thead> <tr> <th rowspan="2">Width(mm)</th> <th rowspan="2">Length(mm)</th> <th colspan="3">Acceptable Qty</th> </tr> <tr> <th>A</th> <th>B</th> <th>C</th> </tr> </thead> <tbody> <tr> <td>$\Phi \leq 0.03$</td> <td>Ignore</td> <td colspan="2">Ignore</td> <td rowspan="3">Ignore</td> </tr> <tr> <td>$0.03 < W \leq 0.04$</td> <td>$L \leq 3.0$</td> <td colspan="2">$N \leq 2$</td> </tr> <tr> <td>$0.04 < W \leq 0.05$</td> <td>$L \leq 2.0$</td> <td colspan="2">$N \leq 1$</td> </tr> <tr> <td>$0.05 < W$</td> <td colspan="4">Define as spot defect</td> </tr> </tbody> </table>	Width(mm)	Length(mm)	Acceptable Qty			A	B	C	$\Phi \leq 0.03$	Ignore	Ignore		Ignore	$0.03 < W \leq 0.04$	$L \leq 3.0$	$N \leq 2$		$0.04 < W \leq 0.05$	$L \leq 2.0$	$N \leq 1$		$0.05 < W$	Define as spot defect			
Width(mm)	Length(mm)	Acceptable Qty																											
		A	B	C																									
$\Phi \leq 0.03$	Ignore	Ignore		Ignore																									
$0.03 < W \leq 0.04$	$L \leq 3.0$	$N \leq 2$																											
$0.04 < W \leq 0.05$	$L \leq 2.0$	$N \leq 1$																											
$0.05 < W$	Define as spot defect																												
		Assembly deflection	beyond the edge of backlight $\leq 0.2\text{mm}$																										
		Bulge (undulation included)	<p>The ITO film plumped below 0.40mm, it's ok.</p>																										
		Newton Ring	<p>Newton Ring area $> 1/3$ TP area NG</p> <p>Newton Ring area $\leq 1/3$ TP area OK</p>																										



		TP corner broken X : length Y : width Z : height	<table border="1"> <tr> <td>X</td> <td>Y</td> <td>Z</td> </tr> <tr> <td>X≤3mm</td> <td>Y≤3mm</td> <td>Z<COVER thickness s</td> </tr> </table>	X	Y	Z	X≤3mm	Y≤3mm	Z<COVER thickness s	
		X	Y	Z						
X≤3mm	Y≤3mm	Z<COVER thickness s								
TP edge broken X : length Y : width Z : height	<table border="1"> <tr> <td>X</td> <td>Y</td> <td>Z</td> </tr> <tr> <td>X≤4mm</td> <td>Y≤2mm</td> <td>Z<COVER thickness</td> </tr> </table>	X	Y	Z	X≤4mm	Y≤2mm	Z<COVER thickness			
X	Y	Z								
X≤4mm	Y≤2mm	Z<COVER thickness								

*Circuitry broken is not allowed.

* Circuitry broken is not allowed.

Criteria (functional items)

Number	Items	Criteria (mm)
1	No display	Not allowed
2	Missing segment	Not allowed
3	Short	Not allowed
4	Backlight no lighting	Not allowed
5	TP no function	Not allowed



8. Reliability Test Result

Item	Condition	Inspection after test
High Temperature Operating	70℃,96H	Inspection after 2~4hours storage at room temperature, the sample shall be free from defects: 1.Air bubble in the LCD; 2.Non-display; 3.Missing segments/line; 4.Glass crack; 5.Current IDD is twice higher than initial value.
Low Temperature Operating	-20℃, 96HR	
High Temperature Storage	80℃, 96HR	
Low Temperature Storage	-30℃, 96HR	
High Temperature & High Humidity Storage	+60℃, 90% RH ,96 hours.	
Thermal Shock (Non-operation)	-30℃,30 min ↔ 80℃,30 min, Change time:5min 20CYC.	
ESD test	C=150pF, R=330,5points/panel	
	Air:±8KV, 5times; Contact:±6KV, 5 times; (Environment: 15℃~35℃, 30%~60%).	
Vibration (Non-operation)	Frequency range:10~55Hz, Stroke:1.5mm	
	Sweep:10Hz~55Hz~10Hz 2 hours for each direction of X.Y.Z. (6 hours for total) (Package condition).	
Box Drop Test	1 Corner 3 Edges 6 faces,80cm(MEDIUM BOX)	

Remark:

- 1.The test samples should be applied to only one test item.
- 2.Sample size for each test item is 5~10pcs.
- 3.For Damp Proof Test, Pure water(Resistance > 10MΩ) should be used.
- 4.In case of malfunction defect caused by ESD damage, if it would be recovered to normal state after resetting, it would be judged as a good part.
- 5.Failure Judgment Criterion: Basic Specification, Electrical Characteristic, Mechanical Characteristic, Optical Characteristic.



9. Cautions and Handling Precautions

9.1 Handling and Operating the Module

- (1) When the module is assembled, it should be attached to the system firmly.
Do not warp or twist the module during assembly work.
- (2) Protect the module from physical shock or any force. In addition to damage, this may cause improper operation or damage to the module and back-light unit.
- (3) Note that polarizer is very fragile and could be easily damaged. Do not press or scratch the surface.
- (4) Do not allow drops of water or chemicals to remain on the display surface.
If you have the droplets for a long time, staining and discoloration may occur.
- (5) If the surface of the polarizer is dirty, clean it using some absorbent cotton or soft cloth.
- (6) The desirable cleaners are water, IPA (Isopropyl Alcohol) or Hexane.
Do not use ketene type materials (ex. Acetone), Ethyl alcohol, Toluene, Ethyl acid or Methyl chloride. It might permanent damage to the polarizer due to chemical reaction.
- (7) If the liquid crystal material leaks from the panel, it should be kept away from the eyes or mouth. In case of contact with hands, legs, or clothes, it must be washed away thoroughly with soap.
- (8) Protect the module from static; it may cause damage to the CMOS ICs.
- (9) Use finger-stalls with soft gloves in order to keep display clean during the incoming inspection and assembly process.
- (10) Do not disassemble the module.
- (11) Protection film for polarizer on the module shall be slowly peeled off just before use so that the electrostatic charge can be minimized.
- (12) Pins of I/F connector shall not be touched directly with bare hands.
- (13) Do not connect, disconnect the module in the "Power ON" condition.
- (14) Power supply should always be turned on/off by the item 6.1 Power On Sequence & 6.2 Power Off Sequence

9.2 Storage and Transportation.

- (1) Do not leave the panel in high temperature, and high humidity for a long time.
It is highly recommended to store the module with temperature from 0 to 35 °C and relative humidity of less than 70%
- (2) Do not store the TFT-LCD module in direct sunlight.
- (3) The module shall be stored in a dark place. When storing the modules for a long time, be sure to adopt effective measures for protecting the modules from strong ultraviolet radiation, sunlight, or fluorescent light.
- (4) It is recommended that the modules should be stored under a condition where no condensation is allowed. Formation of dewdrops may cause an abnormal operation or a failure of the module.
In particular, the greatest possible care should be taken to prevent any module from being operated where condensation has occurred inside.
- (5) This panel has its circuitry FPC on the bottom side and should be handled carefully in order not to be stressed.