



SPECIFICATION FOR TFT LCD MODULE

CUSTOMER : _____

CUSTOMER MODULE : _____

HL MODEL : HG043HV002T02

Preliminary Specification

Final Specification

Customer Confirmation column:

Approved by : _____ Dept. : _____ Date : _____

Please return one of the copies of the specification with your signature to us within two weeks after you receive this document. If it is not returned, we will assume that you agree to the entire contents of this specification document.

Designed by	Checked by	Approved by



CONTENTS

No.	ITEM	PAGE
1.	GENERAL INFORMATION	4
2.	DIAGRAM FOR LCM	5
3.	I/O CONNECTION & BLOCK DIAGRAM	6~7
4.	ELECTRICAL CHARACTERISTICS	8~9
5.	ELECTRO-OPTICAL CHARACTERISTICS	10~12
6.	RELIABILITY TEST CONDITIONS	13
7.	INSPECTION STANDARDS	14~15
8.	PACKAGE DRAWING	16



1. GENERAL INFORMATION

1.1 features

- 1) Structure: TFT PANNEL+IC+FPC+BL+CTP
- 2) IPS Type LCD 480 dot-segment and 272 dot-common outputs
- 3) 252K Color can be selected by software
- 4) White LED back light
- 5) RGB-24 interface
- 6) Operation Temperature : -20~60℃
- 7) Storage Temperature : -30~70℃
- 8) CTP cover lens : Asahi
- 9) CTP structure : G+G
- 10) LED life time: -/

1.2 General specification

Item of	Contents	Unit
Panel Size	4.3	inch
LCD Type	a-si/TRANSMISSIVE	/
Display mode	Normally White	/
Pixel arrangement	480*3(RGB)*272	Dots
Pixel pitch (W*H)	0.066(V)*0.198(V)	um
Active Area	53.856 x 95.04	Mm
Module area (W*H*T)	105.5*67.2*3.0	Mm
Recommended Viewing Direction	12	0' clock
Interface	RGB-24	/
Luminance for LCM+TP	270	cd/m2
NTSC	52	%
Weight	TBD	g



2. DIAGRAM FOR LCM

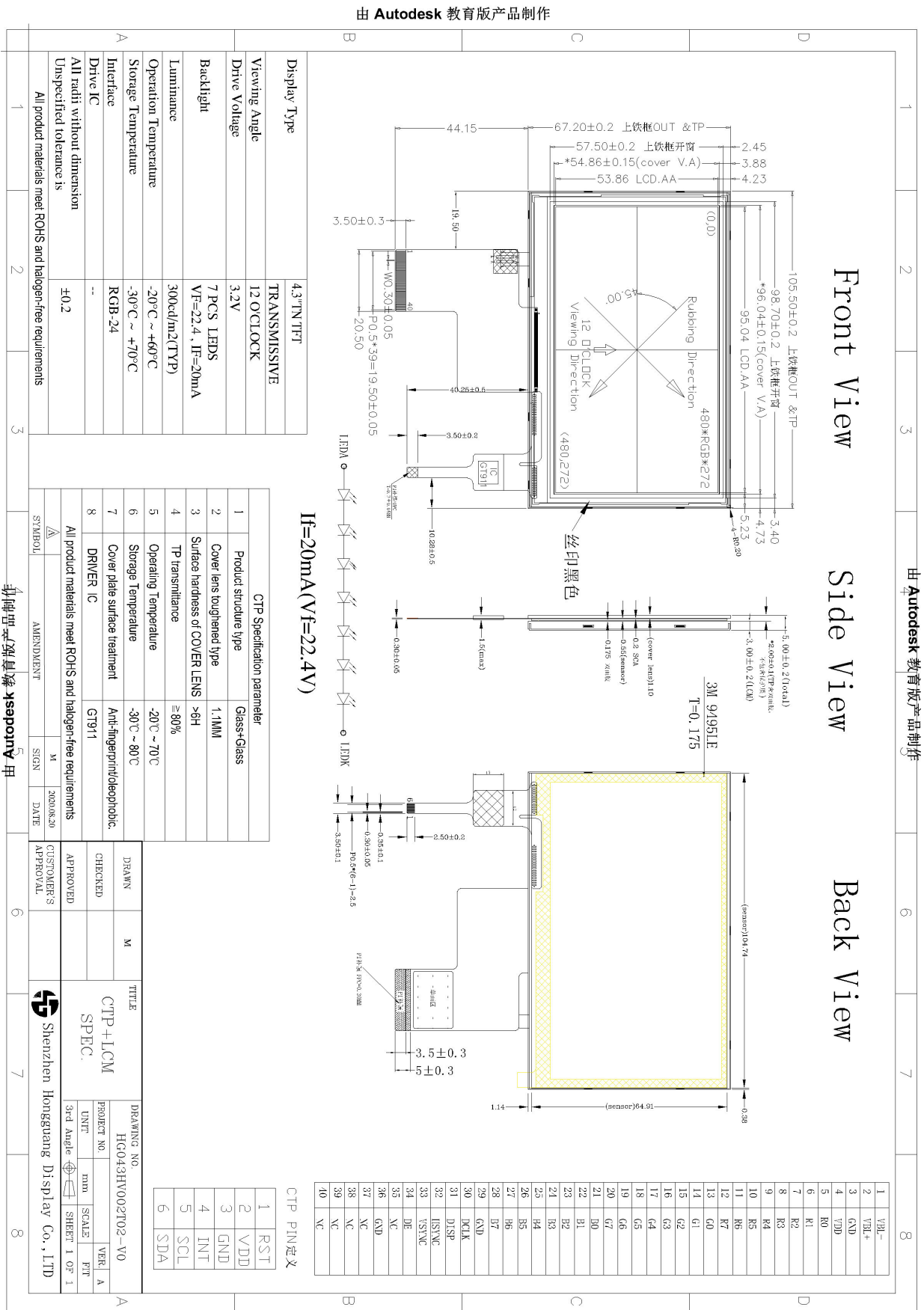



3. I/O CONNECTION & BLOCK DIAGRAM

3.1 I/O connection

LCM Pin NO.	Symbol	I/O	Description
1	LED_K	P	Power supply for LED-
2	LED_A	P	Power supply for LED+
3	GND	P	Power Ground
4	VCC (2.8V)	P	Power supply to the internal logic power regulator(2.8V)
5-12	R0-R7	I	RED data
13-20	G0-G7	I	GREEN data
21-28	B0-B7	I	BLUE data
29	GND	P	Power Ground
30	DCLK	I	Parallel RGB clock input
31	DISP	I	Display control / standby mode selection
32	HSYNC	I	Horizontal sync signal; negative polarity.
33	VSYNC	I	Vertical sync signal; negative polarity.
34	DE	I	DATA INPUT Enable
35	NC	-	No connect
36	GND	P	Power Ground
37-40	NC	-	No connect

I: Input; O: Output; P: Power

TP Pin NO.	Symbol	I/O	Description
1	RST	I	The signal will reset the TP, Signal is active low.
2	AVDD	P	TP-VCC(3.3V) Power Supply for TP
3	GND	P	Power Ground
4	INT	O	Interrupt signals for TP
5	SCL	I	I2C clock signals for TP
6	SDA	I/O	I2C data signals for TP



3.2 block diagram

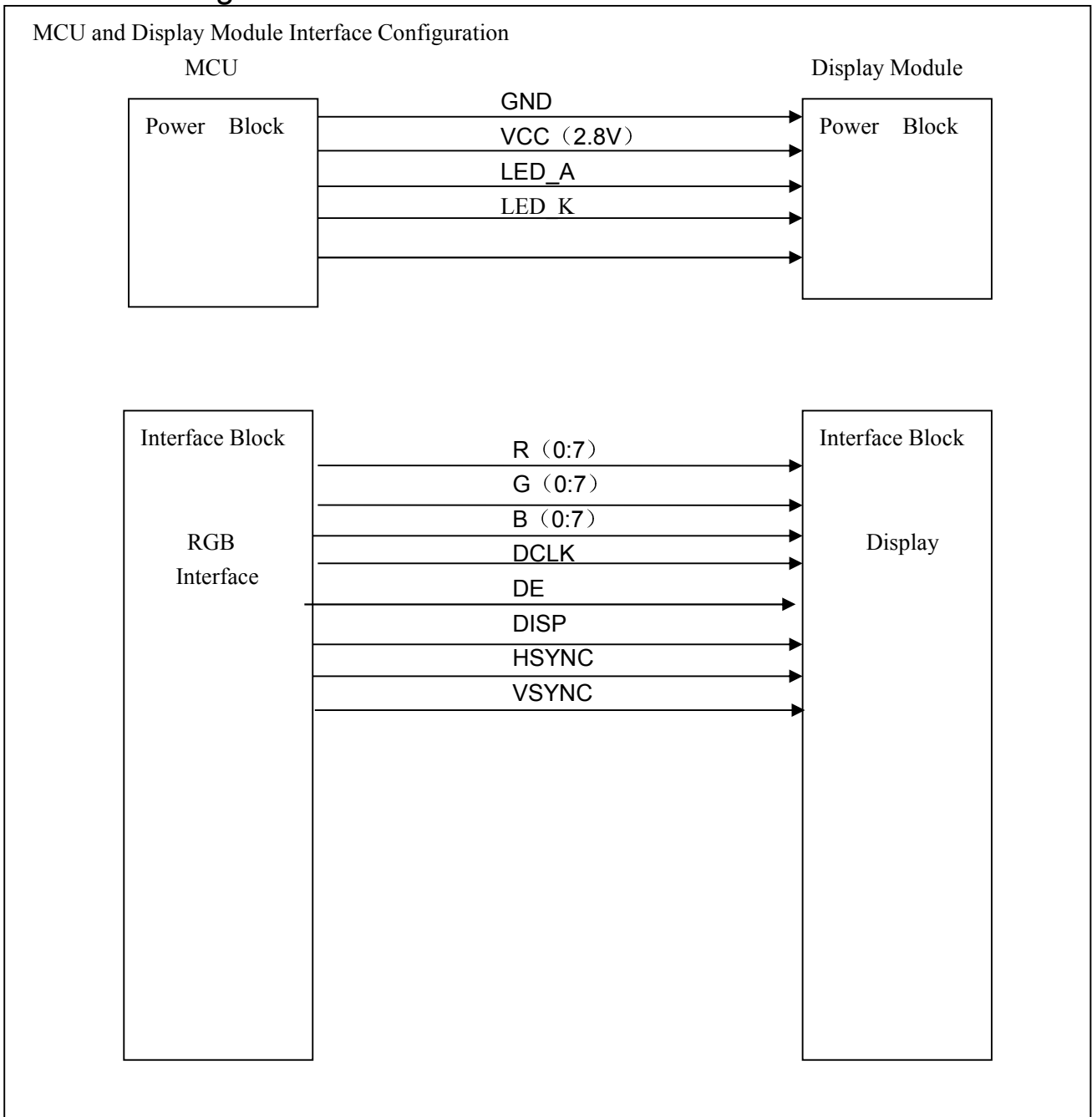



4. ELECTRICAL CHARACTERISTICS

4.1 Typical Operation Conditions

Item	Symbol	Values			Unit	Remarks
		Min.	Typ.	Max.		
Power Voltage Supply1	VCC(2.8V)	3.0	3.3	3.6	V	-
Luminance	Lv	-	270	-	cd/m2	
Backlight Forward Voltage	Vf	-	22.4	-	V	-
LED Forward Current	If	-	20	-	MA	Note

Note: The "LED life time" is defined as the module brightness decrease to 50% of original brightness at $I_L=20\text{mA}$ (for each led). The LED life time could be decreased if operating I_L is larger than 20mA



背光电路图



4.2 DC CHARACTERISTICS

Item	Symbol	Condition	Min.	Typ.	Max.	Unit
Input high voltage	V _{IH}		0.7*V _{DDI}	-	V _{DDI}	V
Input low voltage	V _{IL}		V _{SS}	-	0.3*V _{DDI}	V
Output high voltage	V _{OH}	I _{OH} =-1.0mA I _{OL} =+1.0mA	0.8*V _{DDI}	-	V _{DDI}	V
Output low voltage	V _{OL}		V _{SS}	-	0.2*V _{DDI}	V
Current for main LCD	I _{cc}	-	-	-	TBD	mA

4.3 OPERATING PRINCIPLES & METHODS

Please refer to ST7282-G4 atasheet for more details.

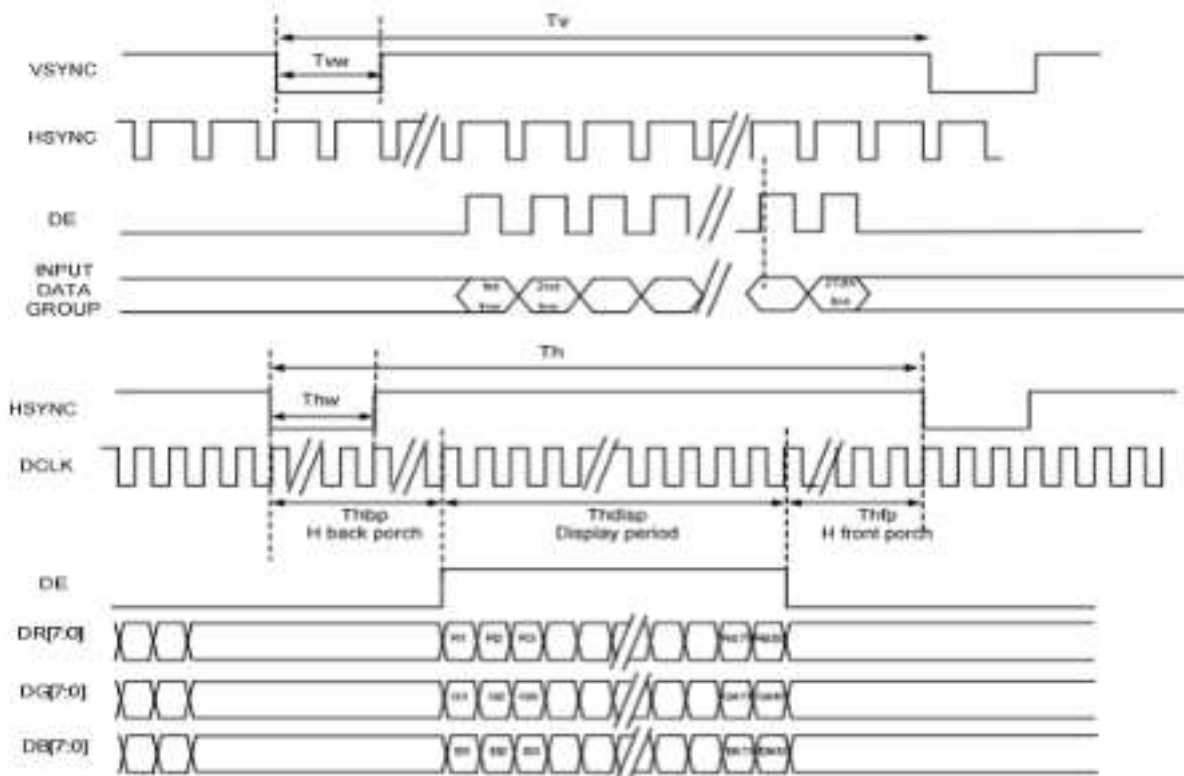



5. ELECTRO-OPTICAL CHARACTERISTICS

Parameter		Symbol	Condition	Min.	Typ.	Max.	Unit	Note
Contrast Ratio (Center point)		C/R	-	-	500	-	-	Note(1)
Luminance uniformity		U _w	θ = 0. Normal viewing angle B/L On Note(1)	80	85	-	%	Note(2)
Response Time		Tr + Tf		-	25	35	ms	Note(3)
Color Chromaticity (CIE 1931)	White	W _x			0.313			Note(5)
		W _y			0.323			
	Red	R _x		0.618				
		R _y		0.343				
	Green	G _x	-0.02	0.306	+0.02			
		G _y		0.527				
	Blue	B _x		0.139				
		B _y		0.098				
Viewing Angle	Hor.	∅ 3R	C/R≥10		70	-	Deg	Note(4)
		∅ 9L			70	-		
	Ver.	∅ 12U			50	-		
		∅ 6D		-	70	-		



Note1 Definition of Contrast Ratio (CR):

$$\text{Contrast ratio (CR)} = \frac{\text{Luminance measured when LCD on the "White" state}}{\text{Luminance measured when LCD on the "Black" state}}$$

Note2: Definition of Luminance Uniformity: Active area is divided into 9 measuring areas (Shown in below), every measuring point is placed at the center of each measuring area.

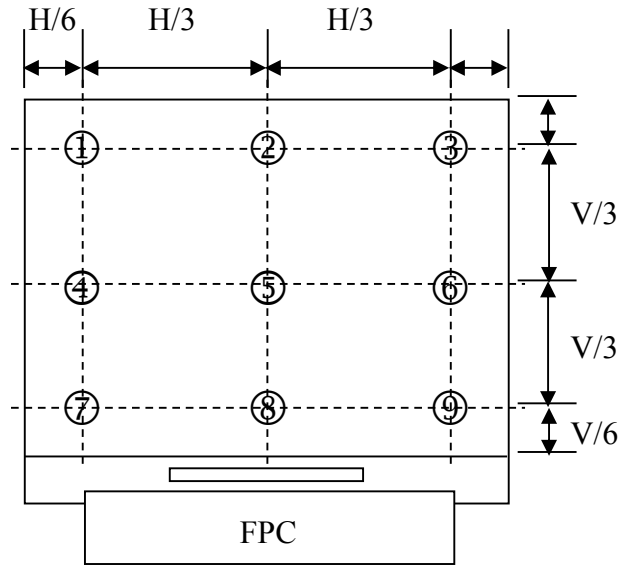

The spot locations for luminance measurement

$$\text{Luminance Uniformity} = \frac{H/6 \cdot B_{\min}}{V/6 \cdot B_{\max}} \times 100\%$$

B_{\max} : The measured maximum luminance of all measurement position.

B_{\min} : The measured minimum luminance of all measurement position.

Note 3: Definition of Response time: Sum of T_r and T_f

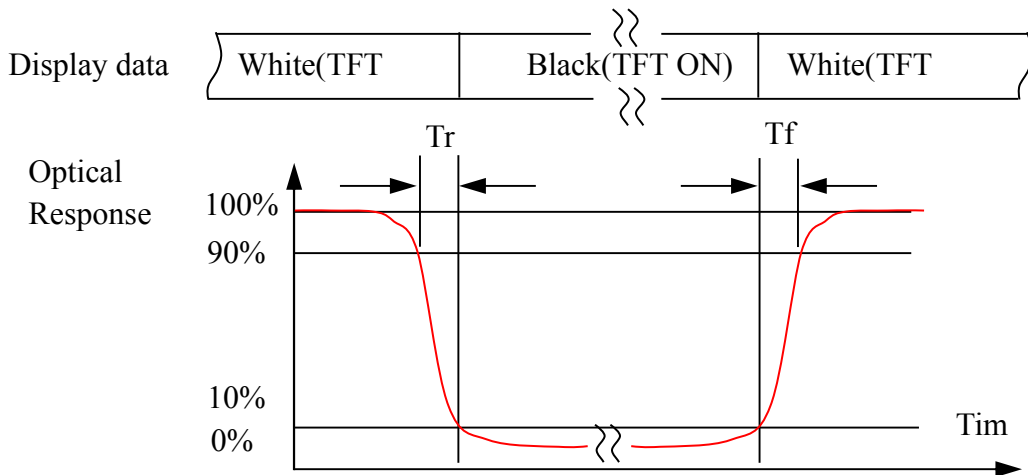



Note4. Definition of Viewing Angle: The viewing angle range that the $CR \geq 10$

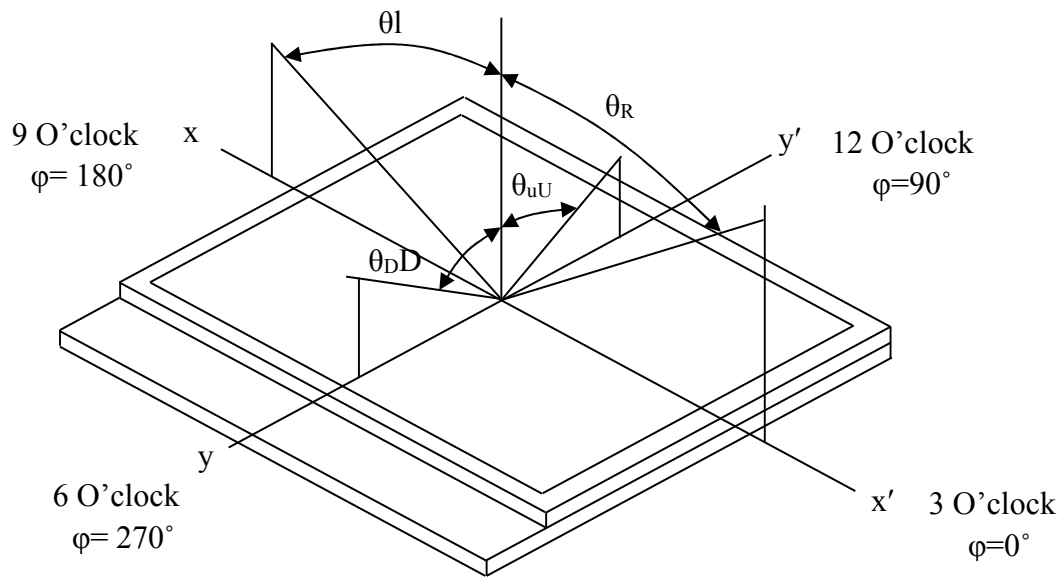

Note 5: Definition of Color Chromaticity (CIE 1931)

Color coordinate of white & red, green, blue at center point.



6. RELIABILITY TEST CONDITIONS

No	Test Item	Test Condition	STANDARD
1	High Temperature Storage	+70°C / 96Hours	1. Functional test is OK. Missing Segment, short, unclear segment, on-display, display abnormally and liquid crystal leak are un-allowed. 2. No low temperature bubbles, end seal loose and fall, frame rainbow.
2	Low Temperature Storage	-30°C / 96Hours	
3	High Temperature Operating	+60°C / 96Hours	
4	Low Temperature Operating	-20°C / 96Hours	
5	Thermal and cold shock	0°C↔+50°C x 10cycles (30min) (5min) (30min)	
6	Operate at High Temperature and Humidity	60°C x 90%RH / 24H	
7	Vibration Test	Frequency: 10Hz~55Hz~10Hz Amplitude:1.5mm, 2 hours for each direction of X, Y, Z	1. Function test is OK. 2. No glass crack, chipped glass, end seal loose and fall, epoxy frame crack and so on. 3. No structure loose and fall.
8	Dropping test	Drop to the ground from 1m height, 1 corner, 3 edges, 6 surfaces.	
9	ESD test	Contact: ±6KV Air: ±10KV 150PF/330Ω,5Points/panel,5times	The test results shall be subject to the whole machine test.

NOTE:

1. The reliability items will be fully performed in new sample qualification,
2. The reliability status will be tested as monitor during mass production. Individual reliability test shall be performed by lot, Moreover, the individual reliability item shall be decided according to reliability plan.
3. All samples are inspected after keeping in the room with normal temperature and humidity for 2 hours or above.
4. Vibration test: It is not necessary to test for those products without assembly frame, backlight, PCB and so on.
5. Dropping test: It is necessary for affirming new package.
6. For the high temperature and high humidity test, pure water of over 10 MΩ.cm should be used.
7. Each test item applies for test LCM only once. Then tested LCM cannot be used again in any other test item.
8. The quantity of LCM examination for each test item is 5pcs to 10pcs.



7. INSPECTION STANDARDS

8.1 AQL Sampling inspection standard

使用 GB/T 2828-2003 一般 II 水平, 采用正常检查一次抽样方式; 具体抽检方式参照《成品检验管理程序》、《抽样管理规范》

缺陷区分	AQL 允收水准
严重缺陷	0 收 1 退
重缺	0.4
轻缺	1.0

8.2 Inspect the condition

8.2.1 在 20—40W 日光灯的照明条件下, 样品离检查者眼睛约 30cm 处进行检查。检验方向以垂直线前后左右 45° (以时钟 3 点、6 点、9 点、12 点)

8.2.2 检验者视力需达到标准视力 1.0 以上。

8.2.3 检验者需戴静电手环、两手八个手指套。

8.2.4 外观检验者以目视检查或以菲林对比卡比对。

8.2.5 电性测试使用电测测架, 主板, 电源线及单片机。

8.2.6 若标准与规格书不符时, 以产品发行之规格书特殊检验规格、工程变更为准

8.2.7 辉色度检测请参照样品, 检测方法依照辉色度检验标准。

8.2.8 电测检验环境: 照度为 200LUX 以下, 外观检验环境: 照度为 600LUX-1000LUX, 检验时间: 1 秒-3 秒。

8.2.9 检验工具: 电测测架, 主板, 电源线及单片机, 菲林对比卡, 游标卡尺, 放大镜, 实体显微镜 (必要时) 等等。

8.3 Judgment criterion

小尺寸点、线判定标准: (6.2 寸以内)

1	点状缺陷 (磨伤、异物、针孔、凹痕、缺膜、气泡、白点、彩点、脏点)		判定 (A/B/C 区)	$D \leq 0.10$, 忽略不计, 但密集型不允许	MI	OK
				$0.1 < D \leq 0.15$, $ds \geq 10$		$N \leq 2$
				$0.15 < D \leq 0.2$, $ds \geq 10$		$N \leq 1$
				LCD 亮点: $0.15 < D$		$N \leq 1$
				$D > 0.2$		NG
			判定 (D 区)	同背面丝印油墨区杂质判定标准		
			注: 1) D 区的点状缺陷需在不影响 CTP 功能、客户组装及整机的外观的情况下, 判定 OK		MI	
2	线状缺陷 (磨伤、无感划伤、毛屑、纤维等)		判定 (A/B/C 区)	$W \leq 0.03mm$, $L \leq 3mm$, $ds \geq 10$	MI	$N \leq 2$
				$0.03mm < W \leq 0.05mm$, $L \leq 3mm$, $ds \geq 10$		$N \leq 1$
				$W > 0.05mm$ 或 $L > 3mm$		NG



中尺寸点、线判定标准：(6.2 8 寸以内)

1	点状缺陷 (磨伤、异物、针孔、凹痕、缺膜、气泡、白点、彩点、脏点)		判定 (A /B/C 区)	$D \leq 0.10$, 忽略不计, 但密集型不允许	MI	OK
				$0.15 < D \leq 0.25$, $ds \geq 10$		$N \leq 2$
				$0.25 < D \leq 3$, $ds \geq 10$		$N \leq 1$
				LCD 亮点: $0.2 < D$		$N \leq 1$
				$D > 0.3$		NG
			判定 (D 区)	同背面丝印油墨区杂质判定标准		
			注: 1) D 区的点状缺陷需在不影响 CTP 功能、客户组装及整机的外观的情况下, 判定 OK		MI	
2	线状缺陷 (磨伤、无感划伤、毛屑、纤维等)		判定 (A /B/C 区)	$W \leq 0.03mm$, $L \leq 3mm$, $ds \geq 10$	MI	$N \leq 2$
				$0.03mm < W \leq 0.05mm$, $L \leq 3mm$, $ds \geq 10$		$N \leq 1$
				$W > 0.05mm$ 或 $L > 3mm$		NG

大尺寸点、线判定标准：(8.1~13.3 寸以内)

1	点状缺陷 (磨伤、异物、针孔、凹痕、缺膜、气泡、白点、彩点、脏点)		判定 (A /B/C 区)	$D \leq 0.1$, 忽略不计, 但密集型不允许	MI	OK
				$0.15 < D \leq 0.3$, $ds \geq 10$		$N \leq 2$
				$0.3 < D \leq 0.35$, $ds \geq 10$		$N \leq 1$
				LCD 亮点: $0.25 < D$		$N \leq 1$
				$D > 0.35$		NG
			判定 (D 区)	同背面丝印油墨区杂质判定标准		
			注: 1) D 区的点状缺陷需在不影响 CTP 功能、客户组装及整机的外观的情况下, 判定 OK		MI	
2	线状缺陷 (磨伤、无感划伤、毛屑、纤维等)		判定 (A /B/C 区)	$W \leq 0.05mm$, $L \leq 5mm$, $ds \geq 10$	MI	$N \leq 2$
				$0.05mm < W \leq 0.07mm$, $L \leq 5mm$, $ds \geq 10$		$N \leq 1$
				$W > 0.07mm$ 或 $L > 5mm$		NG



8. PACKAGE DRAWING

