



# SPECIFICATION FOR TFT LCD MODULE

CUSTOMER : \_\_\_\_\_

CUSTOMER MODULE : \_\_\_\_\_

HL MODEL :           HG050WV032          

Preliminary Specification

Final Specification

Customer Confirmation column:

Approved by : \_\_\_\_\_ Dept. : \_\_\_\_\_ Data : \_\_\_\_\_

Please return one of the copies of the specification with your signature to us within two weeks after you receive this document. If it is not returned, we will assume that you agree to the entire contents of this specification document.

Designed by	Checked by	Approved by



## 1 Document revision history :

DOCUMENT REVISION	DATE	DESCRIPTION	PREPARED BY	APPROVED BY
A	2019.08.14	First Release.	GARY	



## 2. General Feature:

Item	Standard Value	Unit
Display Size	5.0"	--
Number of Pixels	800(V)x3(RGB)x480(H)	--
Active Area	108.00(L) *64.8(W)	mm
Pixel pitch	0.135(L) × 0.135(W)	mm
Outline Dimension	120.80(H) ×75.95(W) × 3.0(T)	mm
Pixel Arrangement	RGB vertical stripe	-
Display Mode	Normally black	-
Number of color	16.7M	-
Viewing Direction	6 O' CLOCK	-
Surface Treatment	Anti-Glare	-
Interface	TTL interface(24bit RGB)	-
Driver IC	HX8264/HX8664	-
Driver Condition	3.3	V
Backlight	White LED	-
Touch Panel	No Touch Panel	-
Operation Temperature	-20~70	°C
Storage Temperature	-30~80	°C





## 4.Pin Description

Pin NO.	Symbol	Description
1	LEDK	Back light cathode
2	LEDA	Back light anode
3	GND	Ground
4	VCC	Power supply
5-12	R0-R7	Data bus
13-20	G0-G7	Data bus(no connect)
21-28	B0-B7	Data bus(no connect)
29	GND	Ground
30	CLK	Colock signal
31	NC	Not connect
32	HS	Line synchronizing signal
33	VSYNC	Frame synchronizing signal
34	DE	Data ENEABLE signal
35	NC	Not connect
36	GND	Ground
37	XR	touch panel X-right
38	YD	touch panel Y-bottom
39	XL	touch panel X-left
40	YU	touch panel Y-upl



## 5. Electrical Characteristics

### 5-1 LED back light specification (per a chip)

Item	Symbol	Condition	Min	Type	Max	Unit
Forward voltage	Vt	If=20mA	17	18	19	V
Forward current	Ipn	/1-chip	-	40	-	mA
Reverse voltage	Vr	Per chip	-	-	4.0	V
Reverse Current	Ir	Vr=4V	-	-	15	uA
Uniformity(with L/G)	-	If=20mA	80	-	-	%
Luminance(With LCD)	Lv	If=20mA	-	300	-	cd/m2
Luminous color	White					



## 6. Timing Characteristics of Input Signals

### 6-1 Display timing characteristics

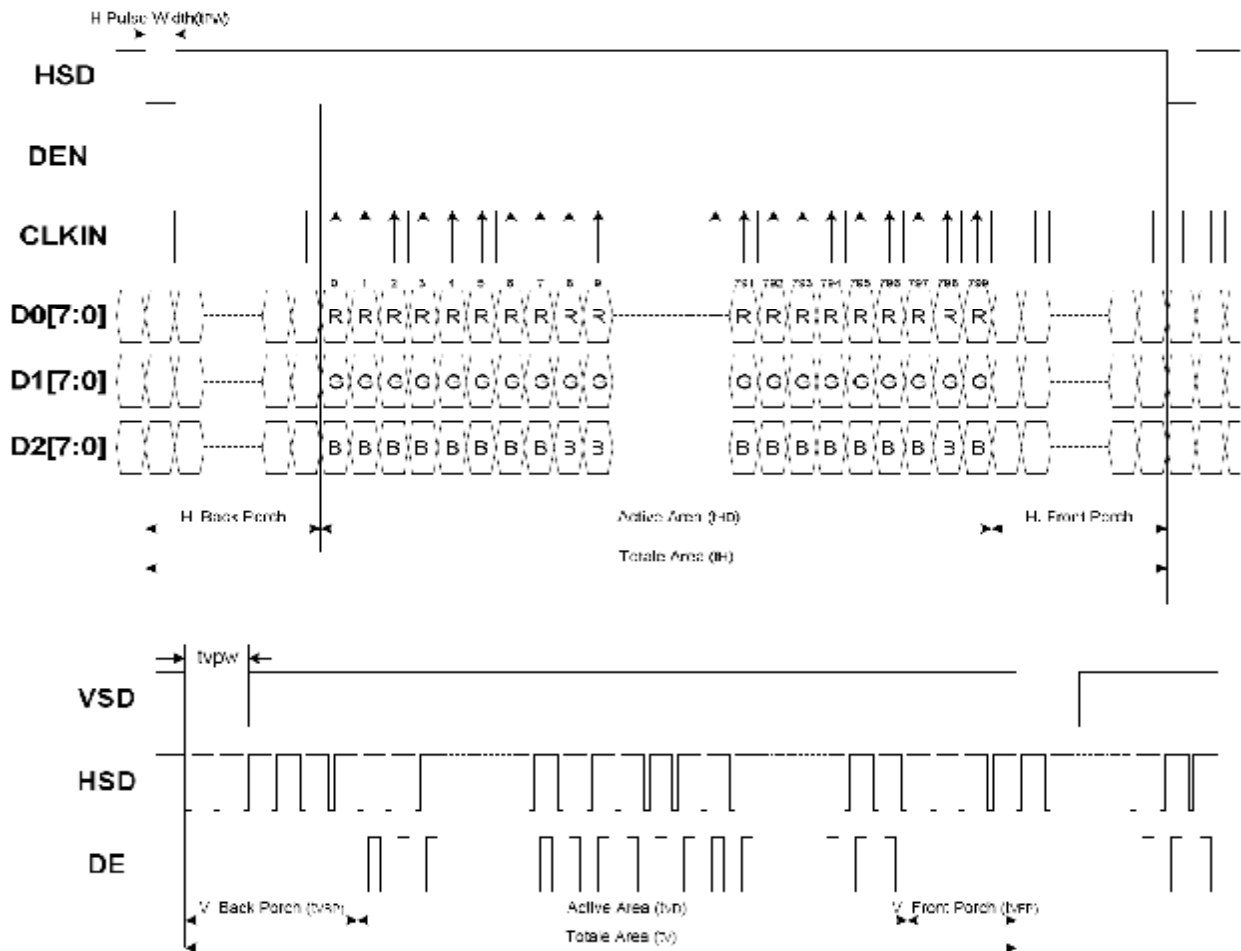

Item	Symbol	Values			Unit	Remark
		Min.	Typ.	Max.		
DCLK Frequency		Fclk	26.4	33.3	46.8	MHz
Hsync	Period time	Th	862	1056	1200	DCLK
	Display Period	Thdisp	-	800	-	DCLK
	Back Porch	Thbp	1	-	40	DCLK
	Front Porch	Thfp	16	210	354	DCLK
Vsync	Period time	Tv	510	525	650	H
	Display Period	Tvdisp	-	480	-	H
	Back Porch	Tvbp	1	-	20	H
	Front Porch	Tvfp	7	22	147	H



## 6-2 Parallel RGB Mode

### DE Mode (MODE='1')

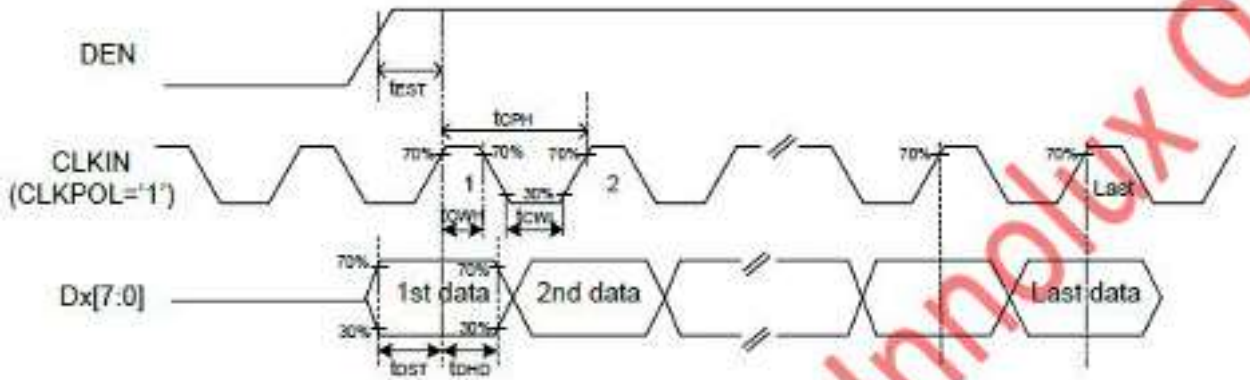

### SYNC Mode (MODE='0')

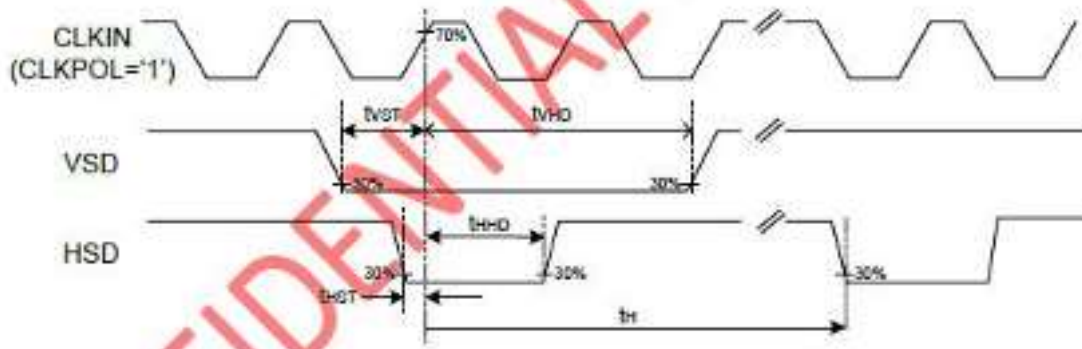

## 7. Power On/Off Sequence

### 7.1 Power On/Off sequence





## a. Power on:

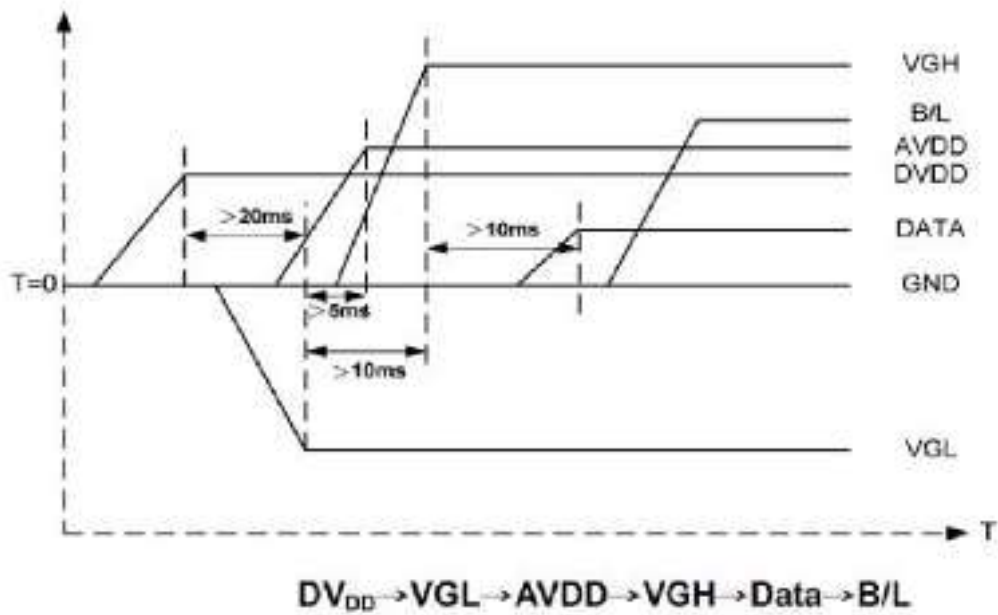

## 7.2 Standby ON/OFF sequence

### b. Power off:

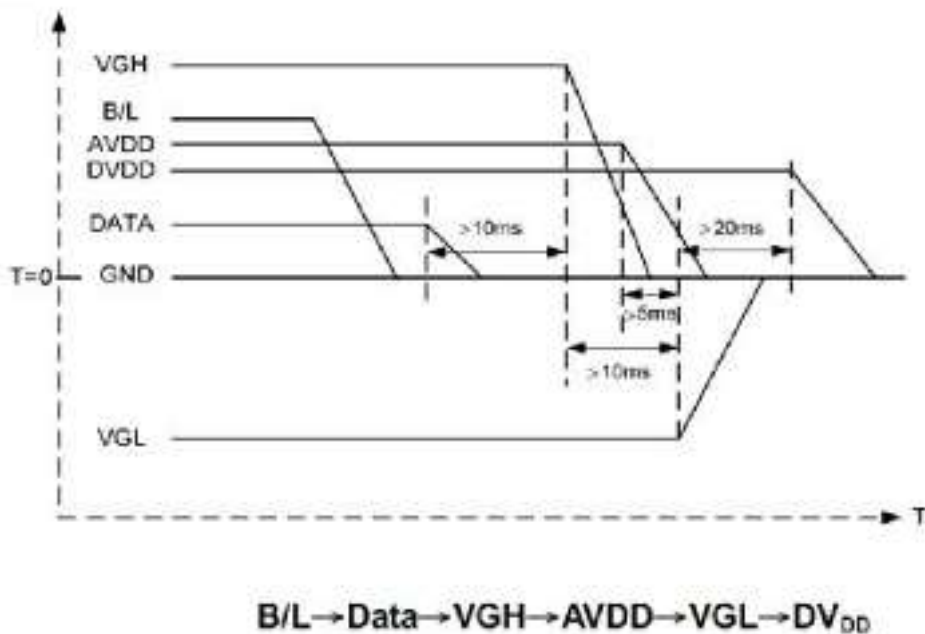

Note: Data include R0-R7, B0-B7, GO-G7, U/D, L/R, DCLK, HS, VS, DE.



## 8. Optical Characteristics

Item	Symbol	Condition	Min	Type	Max	Unit
Transmittance	Tr	-	5.6	6.3	-	%
Contrast Ratio	CR		350	500	-	-
Response time	Tr+Tf		-	25	-	ms
Viewing Angle	U	CR ≥ 10	-	55	-	Deg.
	D		-	35	-	
	L		-	65	-	
	R		-	65	-	
Color of CIE Coordinate	W	x	0.285	0.305	0.325	
		y	0.314	0.334	0.354	
	R	x	0.588	0.608	0.628	
		y	0.296	0.316	0.336	
	G	x	0.285	0.305	0.325	
		y	0.536	0.556	0.576	
	B	x	0.115	0.135	0.155	
		y	0.117	0.137	0.157	

## 9. RELIABILITY TEST

### 9-1 Temperature and Humidity

TEST ITEMS	CONDITIONS	NOTE
High Temperature Operation	70°C ; 48hrs	
High Temperature Storage	80°C ; 96hrs	
High Temperature High Humidity Operation	40°C; 90%RH ; 48hrs (No condensation)	
Low Temperature Operation	-20°C ; 48hrs	
Low Temperature Storage	-30°C ; 96hrs	
Thermal Shock	-20°C (0.5hr) ~ 70°C (0.5hr) ; 10 Cycles	Non-Operating
ESD Test (Non-operation)	150pF, 330 Ω , Contact ±4KV, Air : ±8KV. Note 1	
	200pF, 0 Ω , ±200V Contact test. Note 2	

Note: Measure Point:

1. LCD glass and metal bezel
2. IF connector pins

- END -