



SPECIFICATION FOR TFT LCD MODULE

CUSTOMER : _____

CUSTOMER MODULE : _____

HG MODEL : HG064XG003

Preliminary Specification

Final Specification

Customer Confirmation column:

Approved by : _____ Dept. : _____ Data : _____

Please return one of the copies of the specification with your signature to us within two weeks after you receive this document. If it is not returned, we will assume that you agree to the entire contents of this specification document.

Designed by	Checked by	Approved by



Revision History

Version NO.	DATE	Description	Remak
V1.0	2018.09.12	FIRST ISSUE	



CONTENTS

No.	ITEM	PAGE
1.	GENERAL INFORMATION	4
2.	DIAGRAM FOR LCM	5
3.	I/O CONNECTION & BLOCK DIAGRAM	6~7
4.	ABSOLUTE MAXIMUM RATINGS	8
5.	ELECTRICAL CHARACTERISTICS	9~13
6.	ELECTRO-OPTICAL CHARACTERISTICS	14~16
7.	RELIABILITY TEST CONDITIONS	17
8.	INSPECTION STANDARDS	18~19
9.	PACKAGE DRAWING	20



1. GENERAL INFORMATION

1.1 features

- 1) Structure: TFT PANNEL+IC+FPC+BL
- 2) IPS Type LCD 1024 dot-segment and 768 dot-common outputs
- 3) 16.7M Color can be selected by software
- 4) White LED back light
- 5) LVDS interface
- 6) Operation Temperature : -20~70°C
- 7) Storage Temperature : -25~70°C
- 8) CTP cover lens : -/
- 9) CTP structure : -/
- 10) LED life time: -/

1.2 General specification

Item of	Contents	Unit
Panel Size	6.4	inch
LCD Type	a-si/TRANSMISSIVE	/
Display mode	Normally Black	/
Pixel arrangement	1024*3(RGB)*768	Dots
Pixel pitch (W*H)	0.12675*0.12675	Mm
Active Area	129.792*97.344	Mm
Module area (W*H*T)	153.4*122*9.9	Mm
Recommended Viewing Direction	ALL	0' clock
Interface	LVDS	/
Weight	TBD	g



2. DIAGRAM FOR LCM

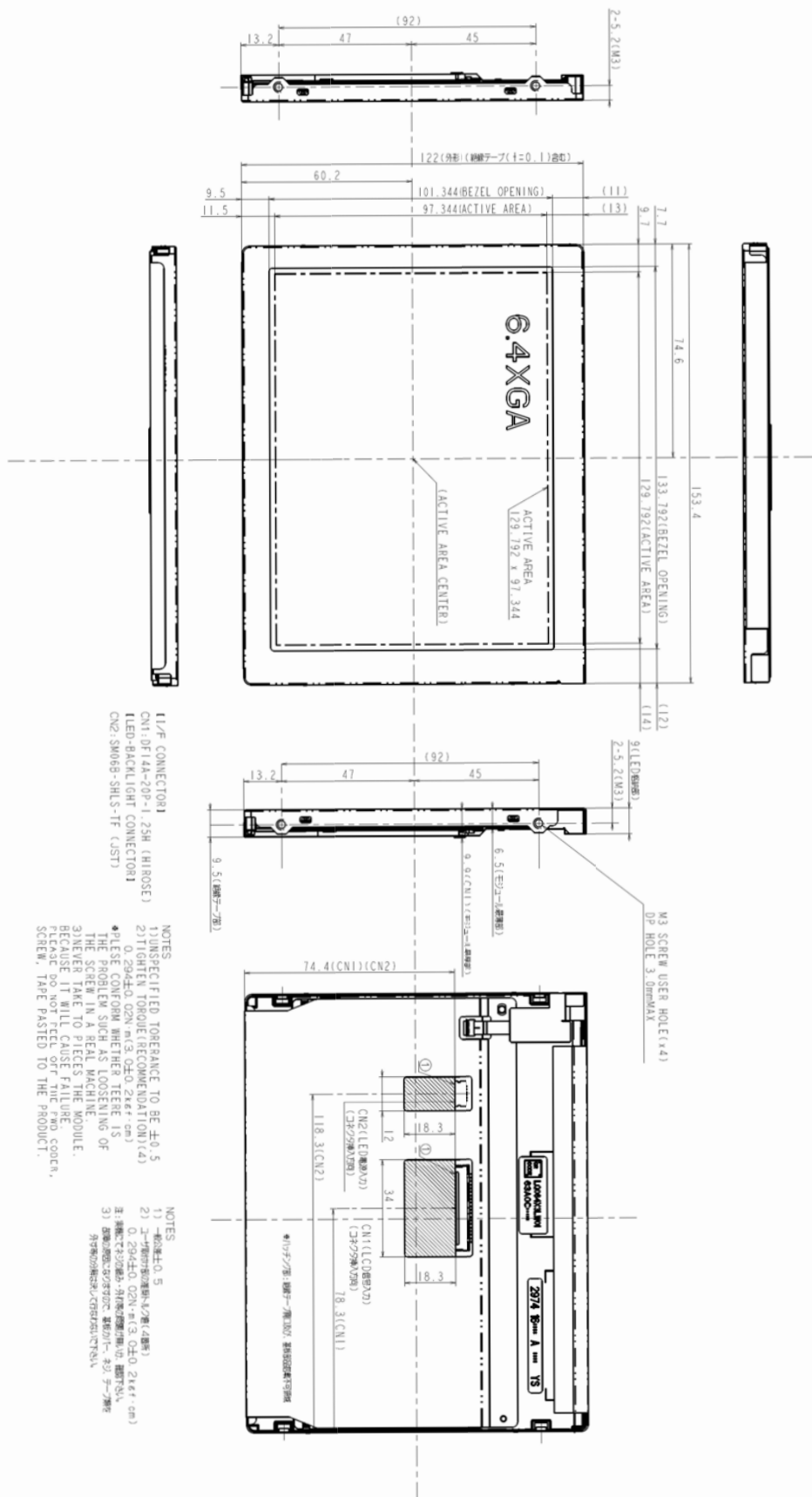



3. I/O CONNECTION & BLOCK DIAGRAM

3.1 I/O connection

Using connector : DF14A-20P-1.25H(HIROSE)

LCM Pin NO.	Symbol	Description
1	VCC	Power supply for digital circuits and IO pads(3.3V)
2	VCC	Power supply for digital circuits and IO pads(3.3V)
3	GND	Power Ground
4	GND	Power Ground
5	RIN0-	LVDS Negative data signal (-)
6	RIN0+	LVDS Negative data signal (+)
7	GND	Power Ground
8	RIN1-	LVDS Negative data signal (-)
9	RIN1+	LVDS Negative data signal (+)
10	GND	Power Ground
11	RIN2-	LVDS Negative data signal (-)
12	RIN2+	LVDS Negative data signal (+)
13	GND	Power Ground
14	LVDS_CLK-	LVDS Negative data signal (-)
15	LVDS_CLK+	LVDS Negative data signal (+)
16	GND	Power Ground
17	RIN3-	LVDS Negative data signal (-)
18	RIN3+	LVDS Negative data signal (+)
19	NC	NC
20	NC	NC

I: Input; O: Output; P: Power



3.2 block diagram

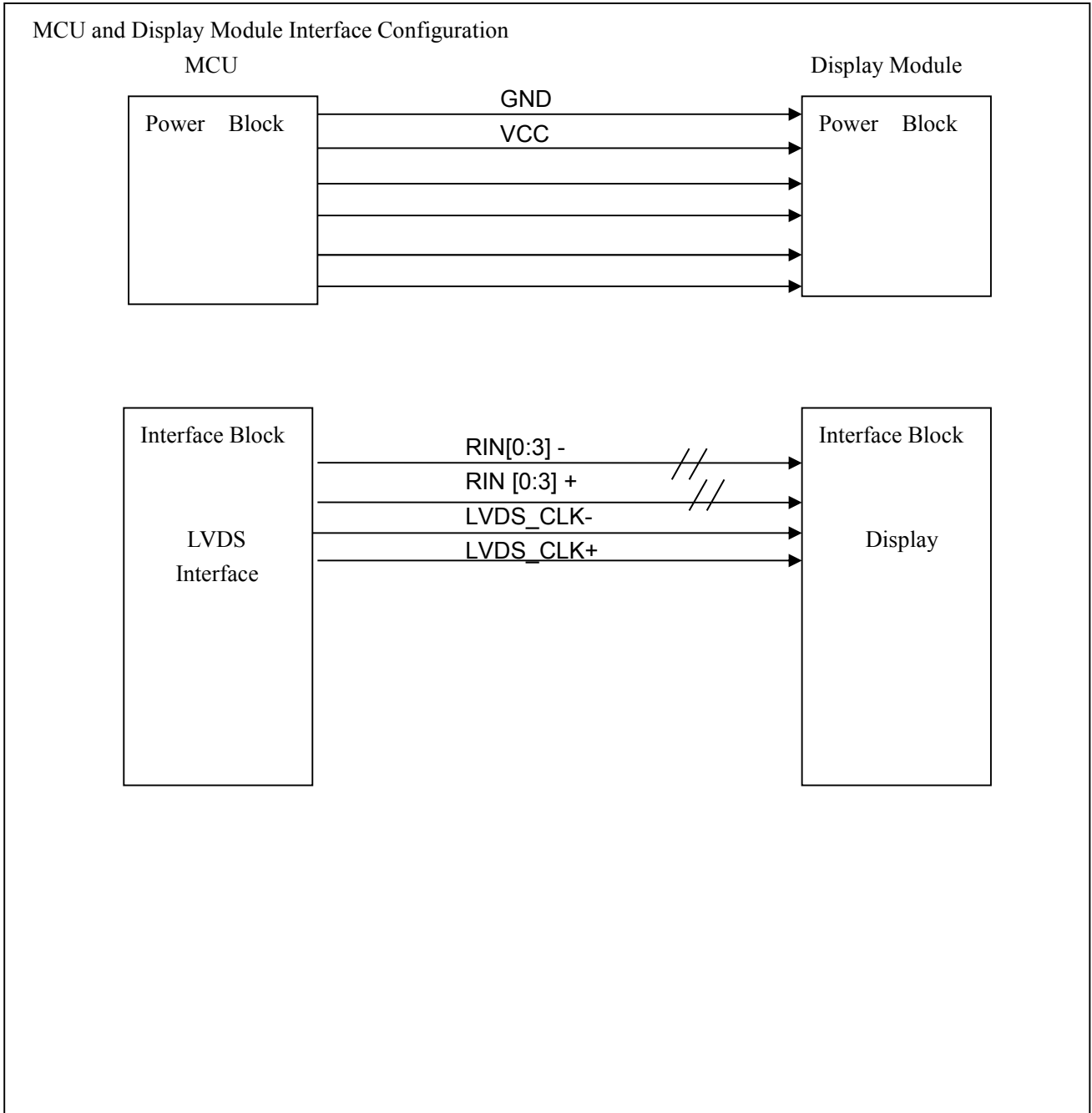



4. ABSOLUTE MAXIMUM RATINGS

(GND=AGND=0V)

Parameter of absolute maximum ratings 参数	Symbol 符号	Min 最小值	Max 最大值	Unit 单位
Power supply voltage1	VCC	0	4	V
Power supply voltage2	VDD	0	15	V
Input voltage	V1(RxIni-/+,C LK In-/+)	-0.3	VCC	V
	V2(BL-EN)	-0.3	VDD	V
	V3(PWM)	-0.3	15	V
Operating temperature	T _{op}	-20	70	°C
Storage temperature	T _{st}	-25	70	°C
Humidity	RH	-	90%(Max)/50°C	RH



5. ELECTRICAL CHARACTERISTICS

5.1 TFT-LCD panel driving

Item	Symbol	Values			Unit	Remarks
		Min.	Typ.	Max.		
Power Voltage Supply1	VCC	3.0	3.3	3.6	V	-
Current dissipation	Icc	-	230	360	mA	
Input voltage for LVDS	VI	0	-	2.4	V	
Permissible input ripple voltage	Vrp	-	-	100	mVp-p	VCC=3.3V
Differential input threshold voltage	High	Vth	-	Vcm+100	mV	Vcm=1.2V
	Low	Vtl	Vcm-100	-	mV	
Terminal resistor	Rt	-	100	-	Ω	Differential input

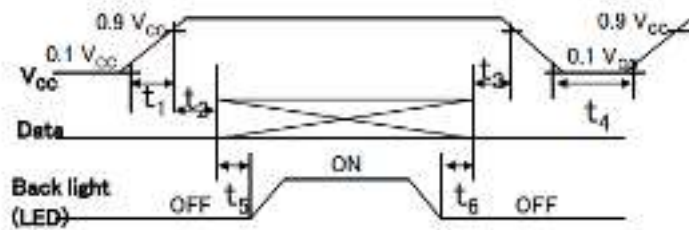

0ms <	t1	≤ 10ms
0ms <	t2	≤ 250ms
0ms <	t3	100ms
400ms ≤	t4	
200ms ≤	t5	
0ms ≤	t6	



5.2 LVDS interface block diagram

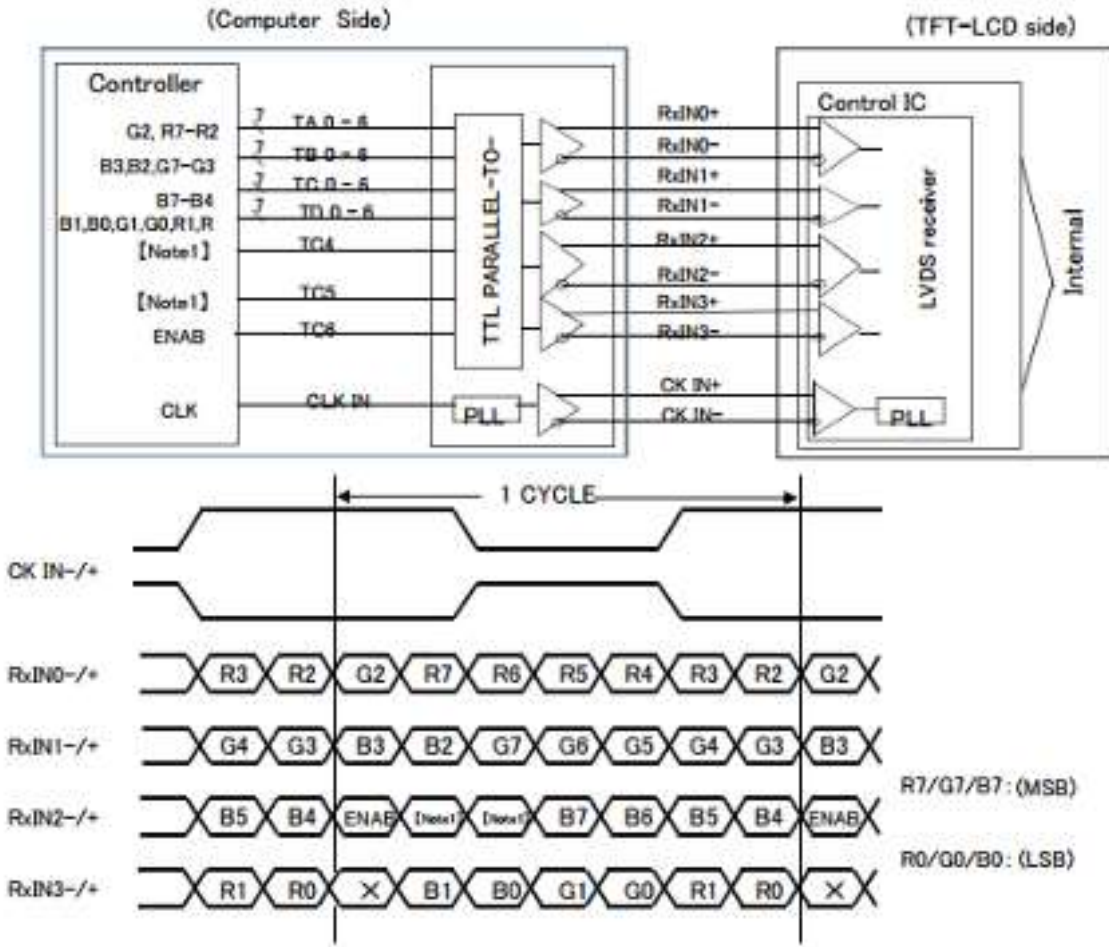

【Note1】 Do not use at high-impedance.

5.3 Backlight section

CN2 Using connectors : SM06B-SHLS-TF (J.S.T. Mfg. Co. Ltd)
Corresponding connectors: SHLP-06V-S-B (J.S.T. Mfg. Co. Ltd)

Connector No.	Pin No.	Symbol	function
CN2	1	VDD	Power supply for backlight
	2	VDD	Power supply for backlight
	3	GND	Ground for backlight
	4	GND	Ground for backlight
	5	BL_EN	ON/OFF control signal for backlight
	6	PWM	PWM signal for backlight dimming



5.4 Backlight driving Section

Ta=+25°C

Parameter	Symbol	Min.	Typ.	Max.	Unit	Remark	
Supply voltage	VDD	10.8	12.0	13.2	V		
Current dissipation	I _{CO}	-	380	460	mA		
Permissive input ripple voltage	V _{RP,BL}	-	-	200	mV _{P-P}		
BL _{EN}	High voltage	V _{H,BLEN}	2.1	-	V _{DD}	V	
	Low voltage	V _{L,BLEN}	0.0	-	0.4	V	
	(High) Leak current(High)	I _{H,BLEN}	-	-	1.5	mA	BL _{EN} =V _{DD}
	(Low) Leak current(Low)	I _{L,BLEN}	-	-	1.0	μA	BL _{EN} =0V
PWM	High voltage	V _{H,PWM}	2.1	-	3.6	V	
	Low voltage	V _{L,PWM}	0.0	-	0.4	V	
	(High) Leak current(High)	I _{H,PWM}	-	-	0.4	mA	PWM=3.6V
	(Low) Leak current(Low)	I _{L,PWM}	-	-	2.0	μA	PWM=0V
PWM frequency	f _{PWM}	200	-	1000	Hz		
PWM duty ratio	D _{PWM}	10	-	100	%		
Life time	L	-	70,000 (Module)	-	h	【Reference】	

【Note1】 On-off conditions for supply voltage

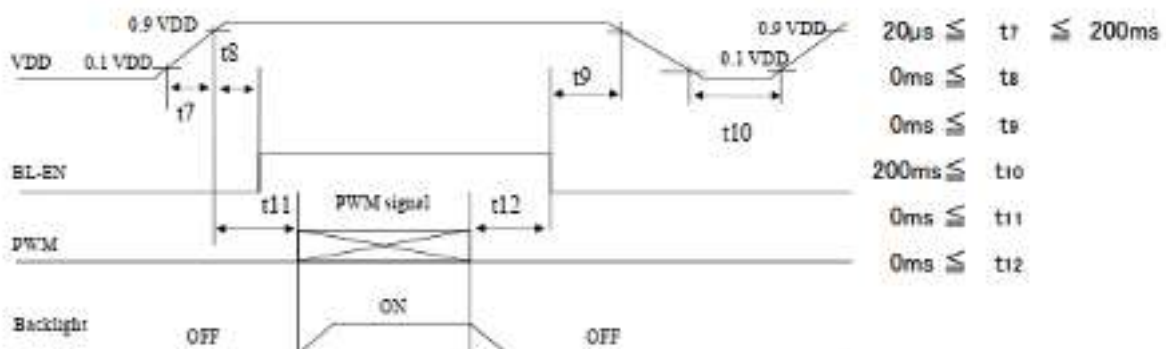

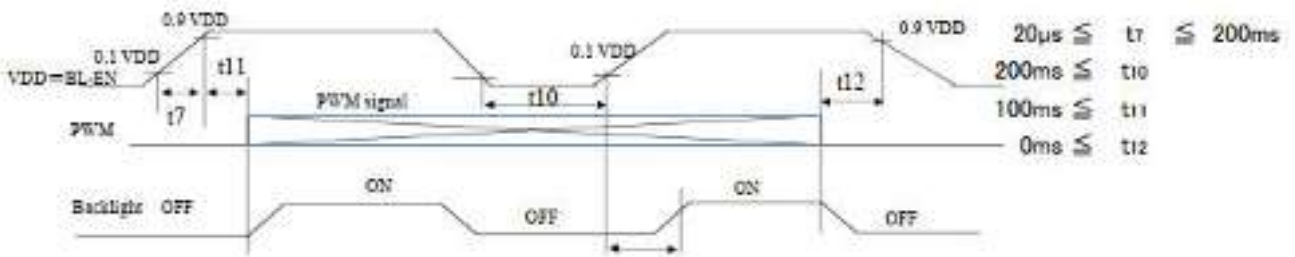

[Note2] Current dissipation
 Typ. value: $V_{DD} = +12V$, Duty=100%
 Max. value: $V_{DD} = +10.8V$, PWM duty = 100%

5.5 Timing Characteristics of Input Signals

Parameter	Symbol	Min.	Typ.	Max.	Unit	Remark	
Clock	Frequency	1/Tc	60	65	80	MHz	
ENAB	Horizontal period	TH	-	1344	-	clock	[Note1]
			-	20.7	-	μs	
	Horizontal display period	THd	-	1024	-	clock	
	Vertical period	TV	-	806	-	line	
			-	16.7	-	ms	
Vertical display period	TVd	-	768	-	line		

[Note1] In case of using the long vertical period, the deterioration of display quality, flicker etc. may occur.

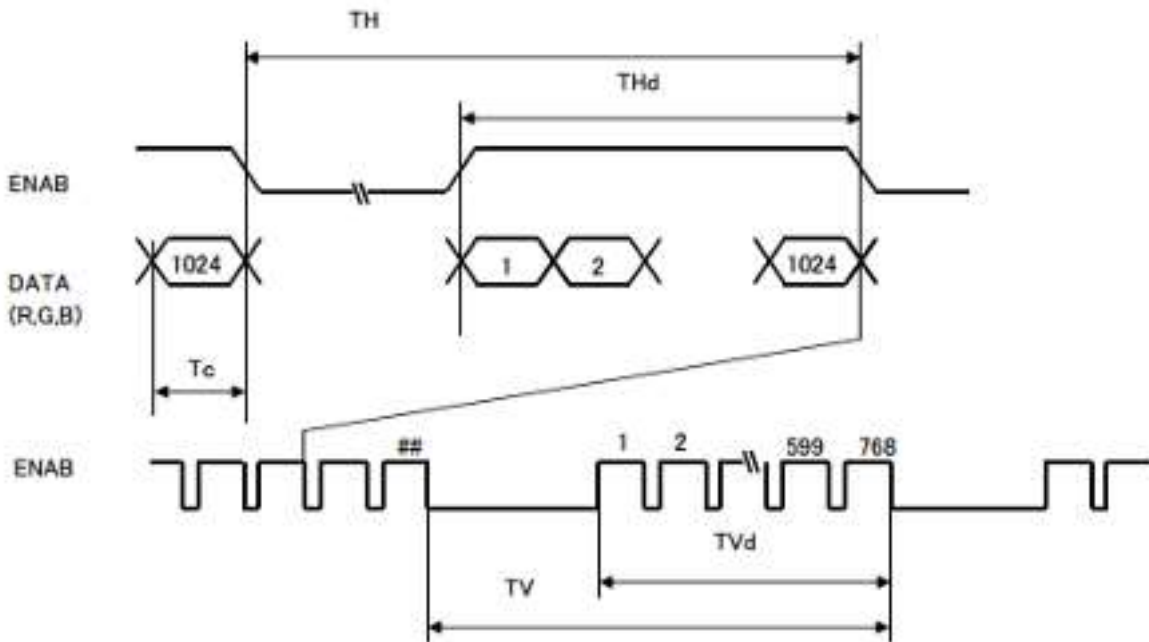



5.6 Input Signals, Basic Display Colors and Gray Scale of Each Color

	Colors & Gray scale	Data signal																											
		GrayScale	R0	R1	R2	R3	R4	R5	R6	R7	G0	G1	G2	G3	G4	G5	G6	G7	B0	B1	B2	B3	B4	B5	B6	B7			
		LSB							MSB	LSB								MSB	LSB							MSB			
Basic Color	Black	-	0	0	0	0	0	0	0	0	0	0	0	0	0	0	0	0	0	0	0	0	0	0	0	0	0		
	Blue	-	0	0	0	0	0	0	0	0	0	0	0	0	0	0	0	0	1	1	1	1	1	1	1	1	1		
	Green	-	0	0	0	0	0	0	0	0	1	1	1	1	1	1	1	1	0	0	0	0	0	0	0	0	0		
	Cyan	-	0	0	0	0	0	0	0	0	1	1	1	1	1	1	1	1	1	1	1	1	1	1	1	1	1		
	Red	-	1	1	1	1	1	1	1	1	0	0	0	0	0	0	0	0	0	0	0	0	0	0	0	0	0		
	Magenta	-	1	1	1	1	1	1	1	1	0	0	0	0	0	0	0	0	1	1	1	1	1	1	1	1	1		
	Yellow	-	1	1	1	1	1	1	1	1	1	1	1	1	1	1	1	1	0	0	0	0	0	0	0	0	0		
	White	-	1	1	1	1	1	1	1	1	1	1	1	1	1	1	1	1	1	1	1	1	1	1	1	1	1		
Gray Scale of Red	Black	GS0	0	0	0	0	0	0	0	0	0	0	0	0	0	0	0	0	0	0	0	0	0	0	0	0	0		
	↑	GS1	1	0	0	0	0	0	0	0	0	0	0	0	0	0	0	0	0	0	0	0	0	0	0	0	0		
	Darker	GS2	0	1	0	0	0	0	0	0	0	0	0	0	0	0	0	0	0	0	0	0	0	0	0	0	0		
	↑	↓																											
	↓	↓																											
	Brighter	GS253	1	0	1	1	1	1	1	1	0	0	0	0	0	0	0	0	0	0	0	0	0	0	0	0	0		
	↓	GS254	0	1	1	1	1	1	1	1	0	0	0	0	0	0	0	0	0	0	0	0	0	0	0	0	0		
	Red	GS255	1	1	1	1	1	1	1	1	0	0	0	0	0	0	0	0	0	0	0	0	0	0	0	0	0		
Gray Scale of Green	Black	GS0	0	0	0	0	0	0	0	0	0	0	0	0	0	0	0	0	0	0	0	0	0	0	0	0	0		
	↑	GS1	0	0	0	0	0	0	0	0	1	0	0	0	0	0	0	0	0	0	0	0	0	0	0	0	0		
	Darker	GS2	0	0	0	0	0	0	0	0	0	1	0	0	0	0	0	0	0	0	0	0	0	0	0	0	0		
	↑	↓																											
	↓	↓																											
	Brighter	GS253	0	0	0	0	0	0	0	0	1	0	1	1	1	1	1	1	0	0	0	0	0	0	0	0	0		
	↓	GS254	0	0	0	0	0	0	0	0	0	1	1	1	1	1	1	1	0	0	0	0	0	0	0	0	0		
	Green	GS255	0	0	0	0	0	0	0	0	1	1	1	1	1	1	1	1	0	0	0	0	0	0	0	0	0		
Gray Scale of Blue	Black	GS0	0	0	0	0	0	0	0	0	0	0	0	0	0	0	0	0	0	0	0	0	0	0	0	0	0		
	↑	GS1	0	0	0	0	0	0	0	0	0	0	0	0	0	0	0	0	1	0	0	0	0	0	0	0	0		
	Darker	GS2	0	0	0	0	0	0	0	0	0	0	0	0	0	0	0	0	0	1	0	0	0	0	0	0	0		
	↑	↓																											
	↓	↓																											
	Brighter	GS253	0	0	0	0	0	0	0	0	0	0	0	0	0	0	0	0	1	0	1	1	1	1	1	1	1		
	↓	GS254	0	0	0	0	0	0	0	0	0	0	0	0	0	0	0	0	0	1	1	1	1	1	1	1	1		
	Blue	GS255	0	0	0	0	0	0	0	0	0	0	0	0	0	0	0	0	1	1	1	1	1	1	1	1	1		

0 :Low level voltage 1 :High level voltage

Each basic color can be displayed in 256 gray scales from 8 bit data signals. According to the combination of total 24 bit data signals, the 16,777,216color display can be achieved on the screen.



6. ELECTRO-OPTICAL CHARACTERISTICS

Parameter		Symbol	Condition	Min.	Typ.	Max.	Unit	Note
Contrast Ratio (Center point)		C/R	-	600	800	-	-	Note(1)
Response Time		Tr + Tf		-	35	-	ms	Note(3)
Color Chromaticity (CIE 1931)	White	W _x			0.305		参考 值	Note(5)
		W _y			0.330			
	Red	R _x			-			
		R _y			-			
	Green	G _x		-0.02	-	+0.02		
		G _y			-			
	Blue	B _x			-			
		B _y			-			
Viewing Angle	Hor.	∅ 3R	C/R≥10	70	80	-	Deg	Note(4)
		∅ 9L		70	80	-		
	Ver.	∅ 12U		70	80	-		
		∅ 6D		70	80	-		



Note1 Definition of Contrast Ratio (CR):

$$\text{Contrast ratio (CR)} = \frac{\text{Luminance measured when LCD on the "White" state}}{\text{Luminance measured when LCD on the "Black" state}}$$

Note2: Definition of Luminance Uniformity: Active area is divided into 9 measuring areas (Shown in below), every measuring point is placed at the center of each measuring area.

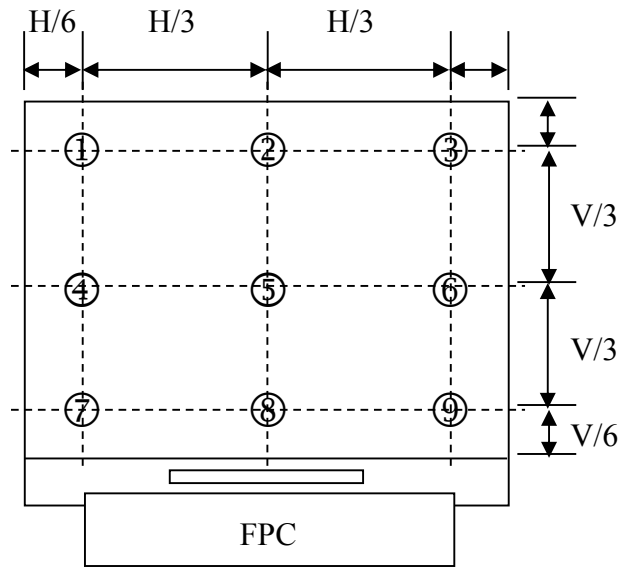

The spot locations for luminance measurement

$$\text{Luminance Uniformity} = \frac{H/6 B_{\min}}{V/6 B_{\max}} \times 100\%$$

B_{\max} : The measured maximum luminance of all measurement position.

B_{\min} : The measured minimum luminance of all measurement position.

Note 3: Definition of Response time: Sum of T_r and T_f

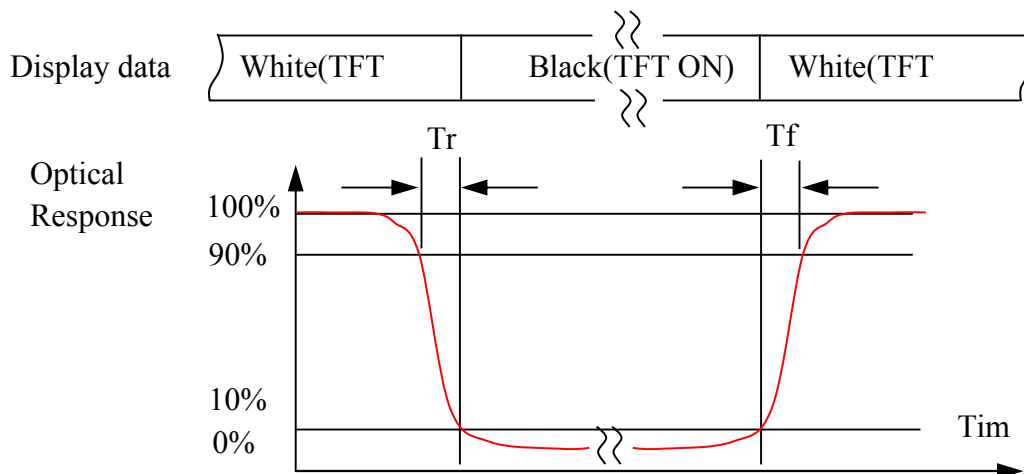



Note4. Definition of Viewing Angle: The viewing angle range that the $CR \geq 10$

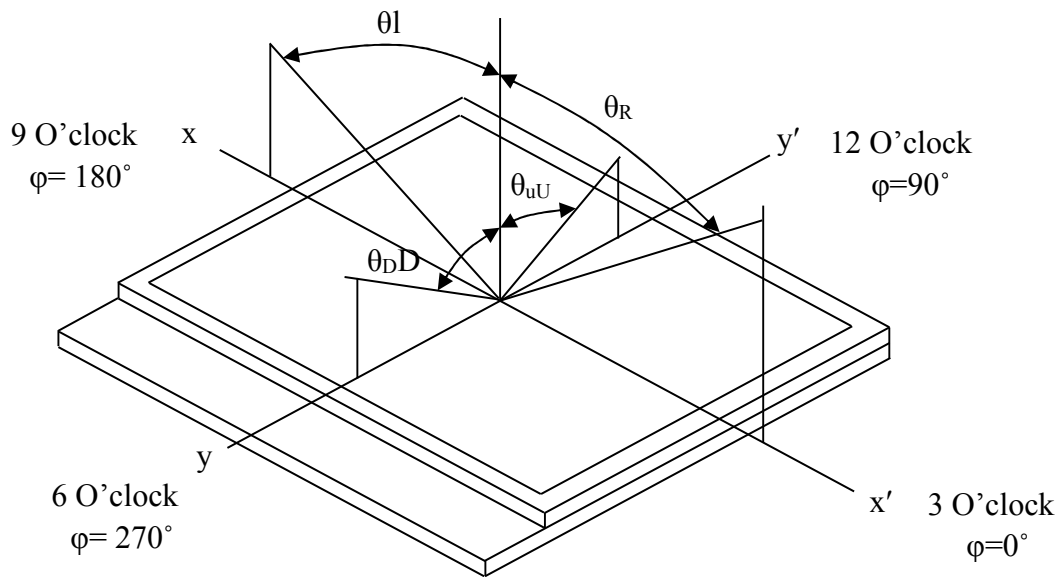

Note 5: Definition of Color Chromaticity (CIE 1931)

Color coordinate of white & red, green, blue at center point.



7. RELIABILITY TEST CONDITIONS

No	Test Item	Test Condition	STANDARD
1	High Temperature Storage	+75°C / 96Hours	1. Functional test is OK. Missing Segment, short, unclear segment, on-display, display abnormally and liquid crystal leak are un-allowed. 2. No low temperature bubbles, end seal loose and fall, frame rainbow.
2	Low Temperature Storage	-20°C / 96Hours	
3	High Temperature Operating	+60°C / 96Hours	
4	Low Temperature Operating	-20°C / 96Hours	
5	Thermal and cold shock	0°C↔+50°C x 10cycles (30min) (5min) (30min)	
6	Operate at High Temperature and Humidity	40°C x 90%RH / 24H	
7	Vibration Test	Frequency: 10Hz~55Hz~10Hz Amplitude:1.5mm, 2 hours for each direction of X, Y, Z	1. Function test is OK. 2. No glass crack, chipped glass, end seal loose and fall, epoxy frame crack and so on. 3. No structure loose and fall.

NOTE:

1. The reliability items will be fully performed in new sample qualification,
2. The reliability status will be tested as monitor during mass production. Individual reliability test shall be performed by lot, Moreover, the individual reliability item shall be decided according to reliability plan.
3. All samples are inspected after keeping in the room with normal temperature and humidity for 2 hours or above.
4. Vibration test: It is not necessary to test for those products without assembly frame, backlight, PCB and so on.
5. Dropping test: It is necessary for affirming new package.
6. For the high temperature and high humidity test, pure water of over 10 MΩ.cm should be used.
7. Each test item applies for test LCM only once. Then tested LCM cannot be used again in any other test item.
8. The quantity of LCM examination for each test item is 5pcs to 10pcs.



8. INSPECTION STANDARDS

8.1 AQL Sampling inspection standard

使用 GB/T 2828-2003 一般 II 水平, 采用正常检查一次抽样方式; 具体抽检方式参照《成品检验管理程序》、《抽样管理规范》

缺陷区分	AQL 允收水准
严重缺陷	0 收 1 退
重缺	0.4
轻缺	1.0

8.2 Inspect the condition

8.2.1 在 20—40W 日光灯的照明条件下, 样品离检查者眼睛约 30cm 处进行检查。检验方向以垂直线前后左右 45° (以时钟 3 点、6 点、9 点、12 点)

8.2.2 检验者视力需达到标准视力 1.0 以上。

8.2.3 检验者需戴静电手环、两手八个手指套。

8.2.4 外观检验者以目视检查或以菲林对比卡比对。

8.2.5 电性测试使用电测测架, 主板, 电源线及单片机。

8.2.6 若标准与规格书不符时, 以产品发行之规格书特殊检验规格、工程变更为准

8.2.7 辉色度检测请参照样品, 检测方法依照辉色度检验标准。

8.2.8 电测检验环境: 照度为 200LUX 以下, 外观检验环境: 照度为 600LUX-1000LUX, 检验时间: 1 秒-3 秒。

8.2.9 检验工具: 电测测架, 主板, 电源线及单片机, 菲林对比卡, 游标卡尺, 放大镜, 实体显微镜 (必要时) 等等。

8.3 Judgment criterion

小尺寸点、线判定标准: (6.2 寸以内)

1	点状缺陷 (磨伤、异物、针孔、凹痕、缺膜、气泡、白点、彩点、脏点)		判定 (A /B/C 区)	$D \leq 0.10$, 忽略不计, 但密集型不允许	MI	OK
				$0.1 < D \leq 0.15$, $ds \geq 10$		$N \leq 2$
				$0.15 < D \leq 0.2$, $ds \geq 10$		$N \leq 1$
				LCD 亮点: $0.15 < D$		$N \leq 1$
				$D > 0.2$		NG
			判定 (D 区)	同背面丝印油墨区杂质判定标准		
			注: 1) D 区的点状缺陷需在不影响 CTP 功能、客户组装及整机的外观的情况下, 判定 OK		MI	
2	线状缺陷 (磨伤、无感划伤、毛屑、纤维等)		判定 (A /B/C 区)	$W \leq 0.03mm$, $L \leq 3mm$, $ds \geq 10$	MI	$N \leq 2$
				$0.03mm < W \leq 0.05mm$, $L \leq 3mm$, $ds \geq 10$		$N \leq 1$
				$W > 0.05mm$ 或 $L > 3mm$		NG



中尺寸点、线判定标准：（6.2~8寸以内）

1	点状缺陷 (磨伤、异物、针孔、凹痕、缺膜、气泡、白点、彩点、脏点)		判定(A/B/C区)	$D \leq 0.10$, 忽略不计, 但密集型不允许 $0.15 < D \leq 0.25$, $ds \geq 10$ $0.25 < D \leq 3$, $ds \geq 10$ LCD亮点: $0.2 < D$ $D > 0.3$	MI	OK
			判定(D区)	同背面丝印油墨区杂质判定标准		N ≤ 2 N ≤ 1 N ≤ 1 NG
			注: 1) D区的点状缺陷需在不影响CTP功能、客户组装及整机的外观的情况下, 判定OK		MI	
2	线状缺陷 (磨伤、无感划伤、毛屑、纤维等)		判定(A/B/C区)	$W \leq 0.03mm$, $L \leq 3mm$, $ds \geq 10$ $0.03mm < W \leq 0.05mm$, $L \leq 3mm$, $ds \geq 10$	MI	N ≤ 2
				$W > 0.05mm$ 或 $L > 3mm$		N ≤ 1
						NG

大尺寸点、线判定标准：（8.1~13.3寸以内）

1	点状缺陷 (磨伤、异物、针孔、凹痕、缺膜、气泡、白点、彩点、脏点)		判定(A/B/C区)	$D \leq 0.1$, 忽略不计, 但密集型不允许 $0.15 < D \leq 0.3$, $ds \geq 10$ $0.3 < D \leq 0.35$, $ds \geq 10$ LCD亮点: $0.25 < D$ $D > 0.35$	MI	OK
			判定(D区)	同背面丝印油墨区杂质判定标准		N ≤ 2 N ≤ 1 N ≤ 1 NG
			注: 1) D区的点状缺陷需在不影响CTP功能、客户组装及整机的外观的情况下, 判定OK		MI	
2	线状缺陷 (磨伤、无感划伤、毛屑、纤维等)		判定(A/B/C区)	$W \leq 0.05mm$, $L \leq 5mm$, $ds \geq 10$ $0.05mm < W \leq 0.07mm$, $L \leq 5mm$, $ds \geq 10$	MI	N ≤ 2
				$W > 0.07mm$ 或 $L > 5mm$		N ≤ 1
						NG



9. PACKAGE DRAWING

