



SPECIFICATION FOR TFT LCD MODULE

CUSTOMER : _____

CUSTOMER MODULE : _____

HG MODEL : HG070WV020

Preliminary Specification

Final Specification

Customer Confirmation column:

Approved by : _____ Dept. : _____ Data : _____

Please return one of the copies of the specification with your signature to us within two weeks after you receive this document. If it is not returned, we will assume that you agree to the entire contents of this specification document.

Designed by	Checked by	Approved by



Contents

1	Introduction-----	4
2	General specification-----	5
3	Mechanical drawing-----	6
4	Absolute maximum ratings-----	7
5	Electrical characteristics-----	7
6	Optical characteristics -----	7
7	Pin Assignment -----	10
8	LCM quality criteria-----	11



1. Introduction

1.1 Scope of application

This specification applies to the Negative type TFT transmissive dot matrix LCD module that is supplied by HG. This LCD module should be designed for mobile Tablet pc Computer tv use. LCD specification: 6:00, Dots 800xRGBx480. As to basic specification of the driver IC, refer to the IC specification and datasheet.

1.2 Structure:

Double display structure:
TFT Module + FPC + BL
FULL Color 7.0 inch TFT LCD size for main LCD;
One bare chip with gold bump (COG) ;
24-bits bus interface;

1.3 TFT features:

Structure: TFT PANNEL+IC+FPC;
Transmissive Type LCD
800 dot-source and 480 dot-gate outputs;
FULL Color;
White LED back light;

1.4 Applications:

Mobile phone, MP5; PC Computer, TV

1.5 This module uses ROHS material



2. General specification

ITEM	Standard value	UNIT
LCD Type	TFT Negative Transmissive	---
Driver element	a-Si TFT Active matrix	
Number of Dots	800*(RGB)*480	Dots
Pixel Arrangement	RGB Vertical Stripe	
Pixel Pitch (W*H)	0.0642(W)x0.1790(H)	um
Display Area	153.84(H) x 85.63(V)	mm
Viewing Direction	6 O'clock	
Module Size(W*H*T)	164.9 (W) × 99.96(H) × 3.5(T)	mm
Approx. Weight	TBD	g
Back Light	White LED	



3 Mechanical drawing

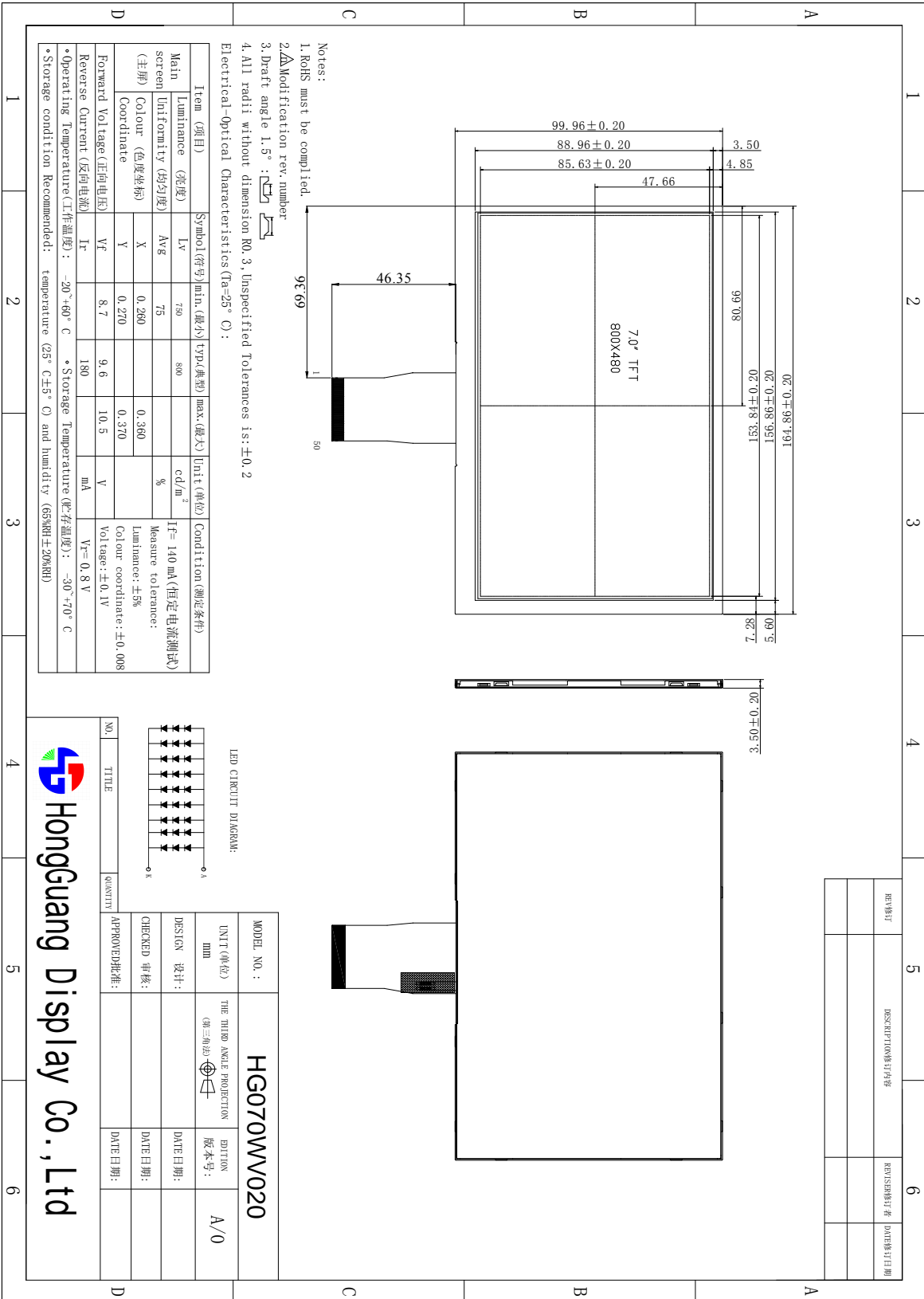



4. ABSOLUTE MAXIMUM RATINGS

Parameter	Symbol	Min	Max	Unit
Supply voltage for logic	V_{DD}	-0.3	3.0	V
Input voltage for logic	V_{IN}	-0.5	$V_{DD} + 0.3$	V
Supply current (One LED)	I_{LED}		20	mA
Operating temperature	T_{OP}	-20	+60	°C
Storage temperature	T_{ST}	-30	+70	°C

5. ELECTRICAL CHARACTERISTICS

Item	Symbol	Min	Typ	Max	Unit	Applicable terminal
Supply voltage for logic	V_{DD}	2.8	3.0	3.3	V	V_{DD}
Input voltage	V_{IL}	-0.3	-	$0.2 V_{DD}$	V	
	V_{IH}	$0.8 V_{DD}$	-	V_{DD}	V	
Input leakage current	I_{LKG}				μA	
AVDD current		9.4	9.6	9.8	V	
VGH current		17	18	19	V	
VGL current		-9	-8	-7	V	
VCOM current		2.8	3.0	3.2	V	
LED Forward voltage	V_f	8.7	9.6	10.5	V	--
Input backlight current	I_{LED}		180		mA	With One LED



6. OPTICAL CHARACTERISTICS

ITEM	SYMBOL	CONDITIONS	SPECIFICATIONS			UNIT	NOTE	
			MIN.	TYP.	MAX			
Brightness	B	Viewing normal angle	750	800	--	Cd/m ²	All left side data are based on LEAD's product reference only	
Contrast Ratio	CR		--	500	--	--		
Response Time	Tr+Tf		--	25	40	ms		
CIE Color coordinate	Red		X _R	--	0.571			
			Y _R		0.352			
	Green		X _G	--	0.345			
			Y _G		0.557			
	Blue		X _B	--	0.148			
			Y _B		0.128			
White	X _w		--	0.314				
	Y _w		0.334					
Viewing Angle	Hor.	θ_{x+}	40	45	--	Deg.		
		θ_{x-}	40	45	--			
	Ver.	θ_{y+}	30	35	--			
		θ_{y-}	10	15				
Uniformity	Un		80	85		%		

Note 1 : Definition of Viewing Angle θ_x and θ_y :

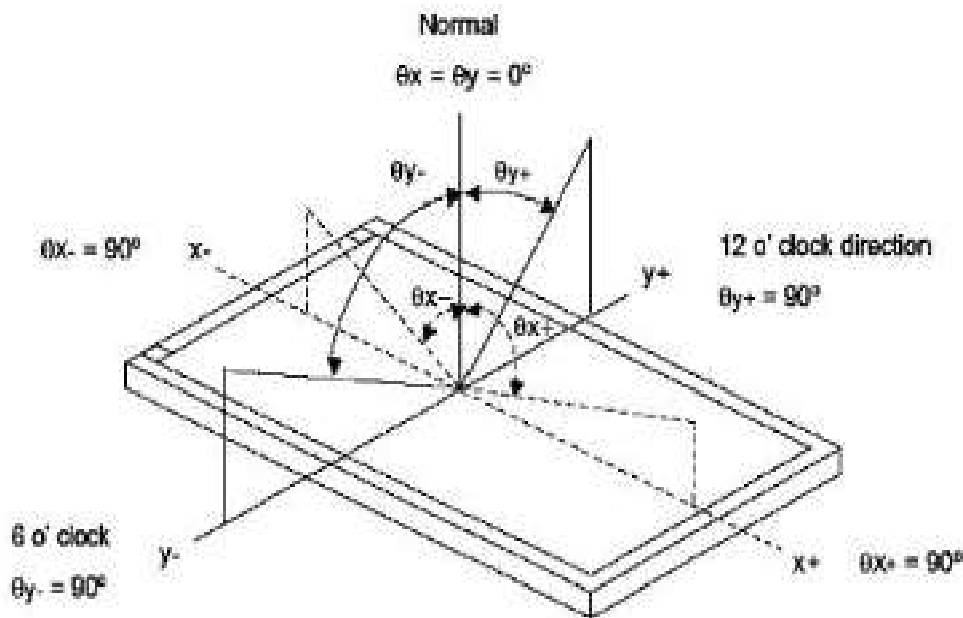



Note 2: Definition of contrast ratio CR:

$$CR = \frac{B_{max}}{B_{min}}$$

Note 3: Definition of response time (T_R, T_F)

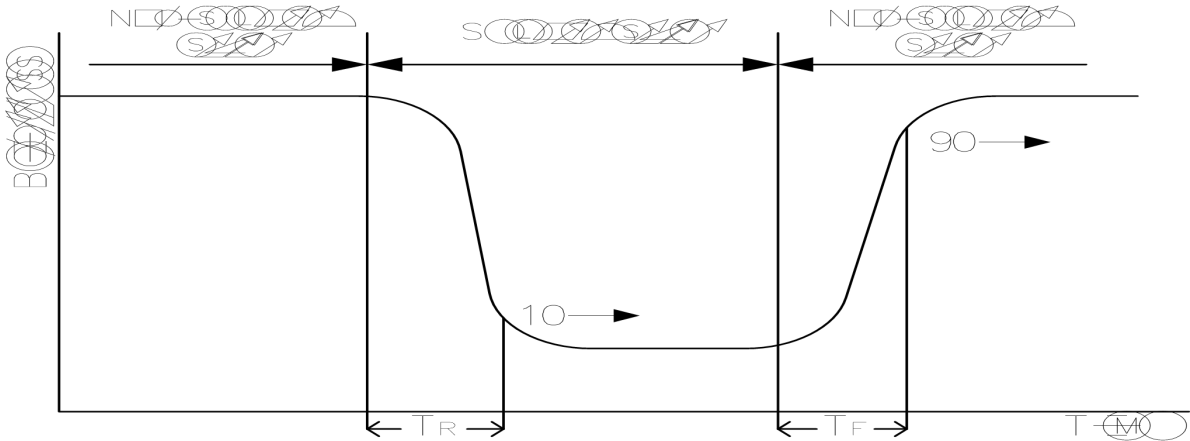



The brightness test equipment setup

20mA Field=2° (As measuring "black" image, field=2° is the best testing condition)

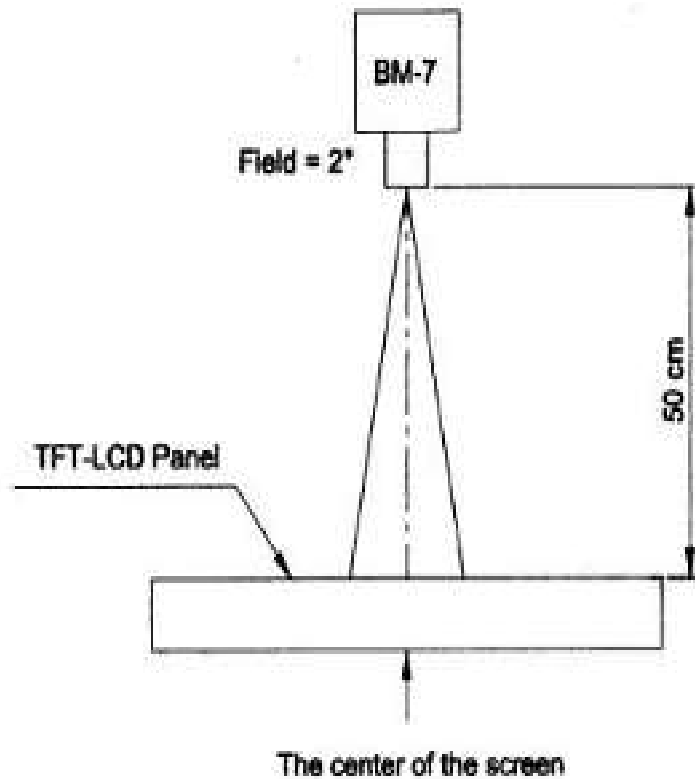

Note 4 :

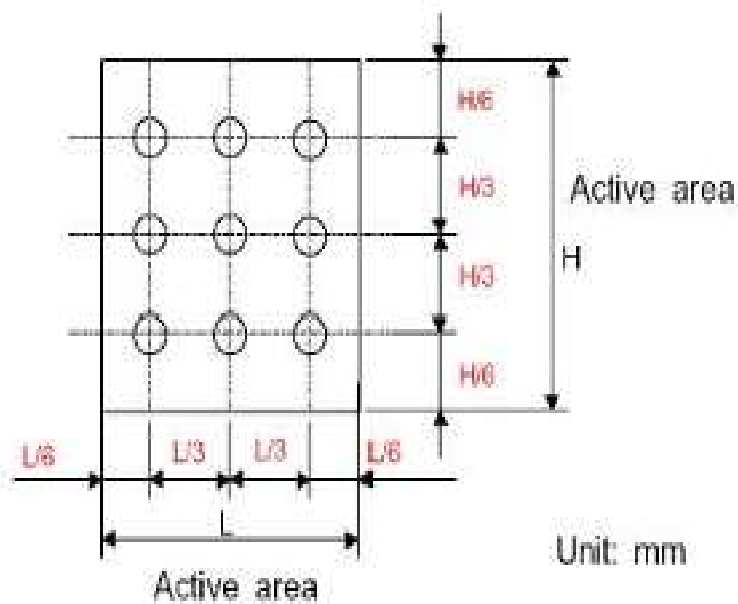



7. HG Interface Pin Function

Pin No.	Symbol	Function
1	LED+	LED Anode
2	LED+	LED Anode
3	LED-	LED Cathode
4	LED-	LED Cathode
5	GND	Ground
6	VCOM	Common Voltage
7	DVDD	Digital Power
8	MODE	DE/SYNC mode select. Normally pull high H: DE mode. L: HSD/VSD mode
9	DE	Data Enable signal
10	VSD	Vertical sync input. Negative polarity
11	HSD	Horizontal sync input. Negative polarity
12-19	B7-B0	Red data bus
20-27	G7-G0	Red data bus
28-35	R7-R0	Red data bus
36	GND	Ground
37	DCLK	Clock input
38	GND	Ground
39	SHLR	Left or Right Display Control
40	UPDN	Up / Down Display Control
41	VGH	Power supply for Gate on output.
42	VGL	Power supply for Gate off output.
43	AVDD	Analog Power
44	RSTB	Global reset pin. Active low to enter reset state. Suggest to connecting with an RC reset circuit for stability. Normally pull high. (R=10KΩ , C=1μF)
45	NC	No connection
46	VCOM	Common Voltage
47	DITHB	Dithering setting DITH="H" 6bit resolution(last 2 bit of input data truncated) DITH="L" 8bit resolution(default setting)
48	GND	Ground
49	NC	No connection
50	NC	No connection



8.LCM Quality Criteria

8.1 RELIABILITY TEST

NO	ITEM	CONDITION	STANDARD
1	High temp. Storage	70°C, 48hrs	No function failure detected.
2	Low temp. Storage	-30°C, 48hrs	No function failure detected.
3	High temp. & High humidity operation	60°C, 90%, 48hrs	No function failure detected.
4	High temp. Operation	60°C, 48hrs	No function failure detected.
5	Low temp. Operation	-20°C, 48hrs	No function failure detected.
6	Thermal shock	-20°C, 30min~60°C, 30min, 10 cycles.	No function failure detected.

The reliability items will be fully performed in new sample qualification.

The reliability status will be tested as monitor during mass production. The individual reliability test shall be managed by lot. Moreover, the individual reliability item shall be decided according reliability plan.

-----TBD