



SPECIFICATION FOR TFT LCD MODULE

CUSTOMER : _____

CUSTOMER MODULE : _____

HL MODEL : _____ HG080WU018T01

Preliminary Specification

Final Specification

Customer Confirmation column:

Approved by : _____ Dept. : _____ Date : _____

Please return one of the copies of the specification with your signature to us within two weeks after you receive this document. If it is not returned, we will assume that you agree to the entire contents of this specification document.

Designed by	Checked by	Approved by



Revision History

Version NO.	DATE	Description	Remak
V1.0	2020.09.05	FIRST ISSUE	



CONTENTS

No.	ITEM	PAGE
1.	GENERAL INFORMATION	4
2.	DIAGRAM FOR LCM	5
3.	I/O CONNECTION & BLOCK DIAGRAM	6~7
4.	ABSOLUTE MAXIMUM RATINGS	8
5.	ELECTRICAL CHARACTERISTICS	8~12
6.	ELECTRO-OPTICAL CHARACTERISTICS	13~15
7.	RELIABILITY TEST CONDITIONS	16
8.	INSPECTION STANDARDS	17~18
9.	PACKAGE DRAWING	19



1. GENERAL INFORMATION

1.1 features

- 1) Structure: TFT PANNEL+IC+FPC+BL+CTP
- 2) IPS Type LCD 1200 dot-segment and 1920 dot-common outputs
- 3) 16.7M Color can be selected by software
- 4) White LED back light
- 5) MIPI-4 interface
- 6) Operation Temperature : -20~60°C
- 7) Storage Temperature : -30~70°C
- 8) CTP cover lens : -/
- 9) CTP structure : -/
- 10) LED life time: -/

1.2 General specification

Item of	Contents	Unit
Panel Size	8.0	inch
LCD Type	a-si/TRANSMISSIVE	/
Display mode	Normally Black	/
Pixel arrangement	1200*3 (RGB)*1920	Dots
Pixel pitch (W*H)	29.9*89.7	um
Active Area	107.64(H)*172.224(V)	Mm
Module area (W*H*T)	116.6(H)*196.6(V)*3.55(T)	Mm
Recommended Viewing Direction	ALL	0' clock
LCM IC	NT51021	/
Interface	MIPI-4	/
Luminance for LCM	300	cd/m2
NTSC	70	%
Weight	TBD	g



深圳市鸿光显示有限公司

2. DIAGRAM FOR LCM

由 Autodesk 教育版产品制作

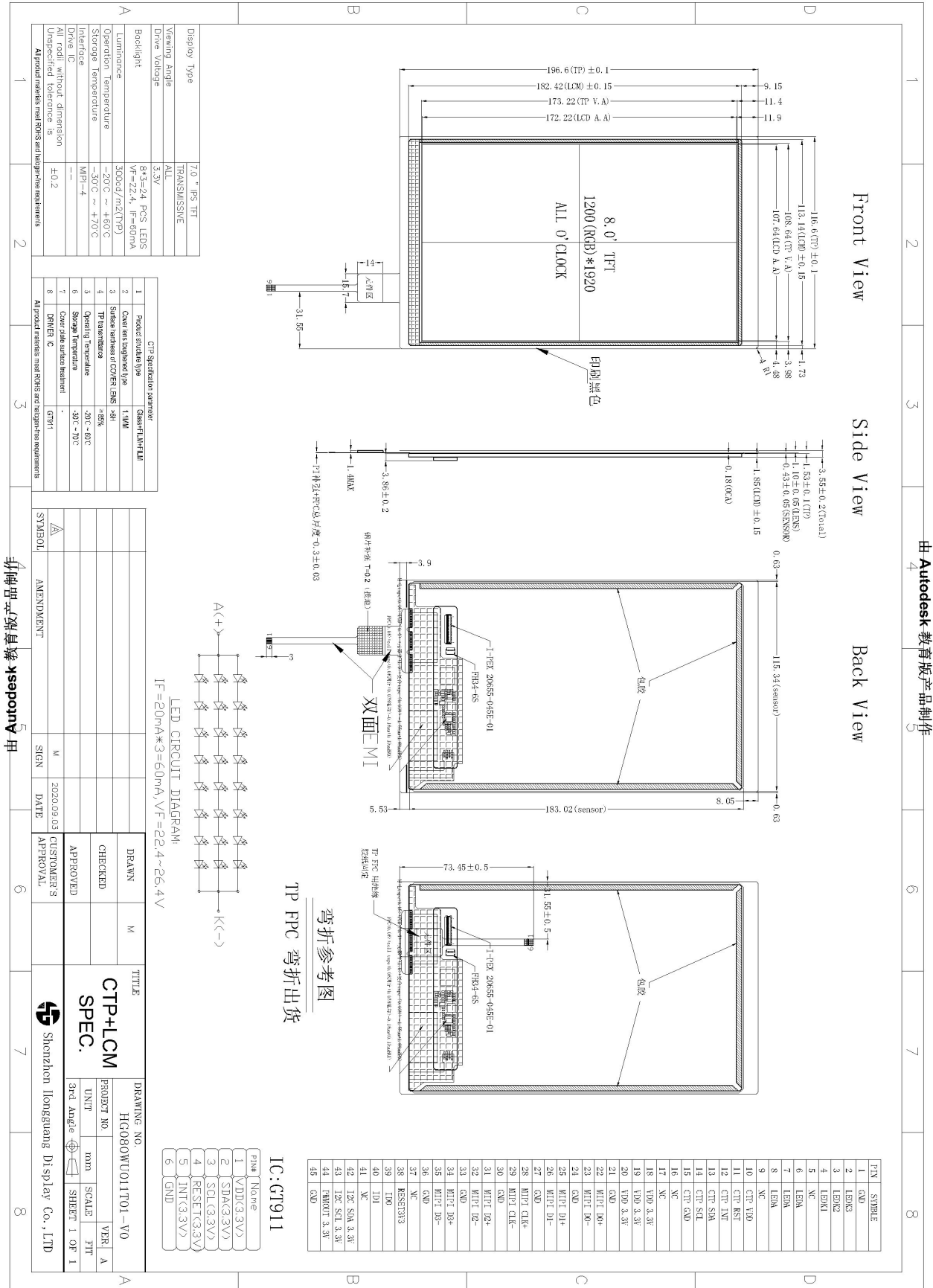

由 Autodesk 教育版产品制作



3. I/O CONNECTION & BLOCK DIAGRAM

3.1 I/O connection

Interface Connector: IPEX 20655-045E-01 is used for the module electronics interface.

LCM Pin NO.	Symbol	I/O	Description
1	GND	GND	GND
2	LEDK3	P	Power supply for LED cathode
3	LEDK2	P	Power supply for LED cathode
4	LEDK1	P	Power supply for LED cathode
5	NC	-	NC
6	LEDA	P	Power supply for LED Anode
7	LEDA	P	Power supply for LED Anode
8	LEDA	P	Power supply for LED Anode
9	NC	-	NC
10	CTP_VDD(3.0V)	-	TP Power supply
11	CTP_RST(1.8V)	-	Reset signal for TP
12	CTP_INT(1.8V)	-	Interrupt signal for TP
13	CTP_SDA(1.8V)	-	I2C data signal for TP
14	CTP_SCL(1.8V)	-	I2C clk signal for TP
15	CTP_GND	-	Ground
16	NC/VPP	-	NC
17	NC	-	NC
18	VDD(3.3V)	P	LCD Power supply
19	VDD(3.3V)	P	LCD Power supply
20	VDD(3.3V)	P	LCD Power supply
21	GND	P	Power Ground
22	TDP0	I	DSI-D0+ differential data signals for MIPI interface
23	TDN0	I	DSI-D0- differential data signals for MIPI interface
24	GND	P	Power Ground
25	TDP1	I	DSI-D1+ differential data signals for MIPI interface
26	TDN1	I	DSI-D1- differential data signals for MIPI interface
27	GND	P	Power Ground
28	TCP	I	DSI-CLK+ differential clock signals for MIPI interface



29	TCN	I	DSI-CLK- differential clock signals for MIPI interface
30	GND	P	Power Ground
31	TDP2	I	DSI-D2+ differential data signals for MIPI interface
32	TDN2	I	DSI-D2- differential data signals for MIPI interface
33	GND	P	Power Ground
34	TDP3	I	DSI-D3+ differential data signals for MIPI interface
35	TDN3	I	DSI-D3- differential data signals for MIPI interface
36	GND	P	Power Ground
37	NC/BIST(3.3V)	-	NC
38	LCD_RESET(3.3V)	I	Reset signal for LCM
39	LCD_ID0	-	ID PIN
40	LCD_ID1	-	ID PIN
41	NC/TP_SYNC(3.3V)	-	NC
42	I2C_SDA(3.3V)	-	I2C data signal for LCM
43	I2C_SCL(3.3V)	-	I2C Clk signal for LCM
44	PWMOUT(3.3)	-	PWM OUT
45	GND	P	Power Ground

I: Input; O: Output; P: Power

3.2 block diagram

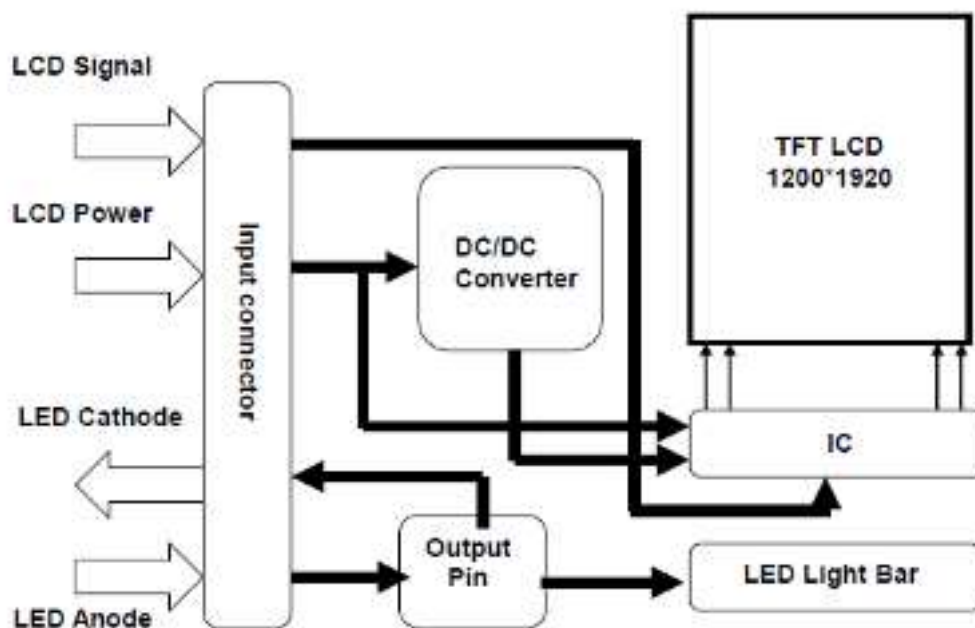



4. ABSOLUTE MAXIMUM RATINGS

(GND=AGND=0V)

Item	Symbol	Values			Unit	Remarks
		Min.	Typ.	Max.		
Power Voltage Supply1	VDD-3.3	-0.3	3.3	5.5	V	
Luminance(LCM)	L _v	250	300	-	cd/m ²	
Backlight Forward Voltage	V _f	21.6	24.4	25.6	V	
LED Forward Current of every LED string	I _f	-	20	25	MA	Note
Operating Temperature	Top	-20	-	60	°C	
Storage Temperature	Tst	-30	-	70	°C	

5. ELECTRICAL CHARACTERISTICS

5.1 LED backlight specification :

项目	符号	额定值	单位
工作电流	I _{BL}	20*3	mA
工作电压	V _{BL}	3.1*8	V
功耗	P _{BL}	1488	mW
亮度	Lum	400 TYP	CD/M ² (*)
X 色坐标	0.26	0.29	0.32
Y 色坐标	0.27	0.30	0.33

Note: The "LED life time" is defined as the module brightness decrease to 50% of original brightness at I_L=20Ma(for each led). The LED life time could be decreased if operating I_L is larger than 20mA

Note: 24 chips (8 series 3 parallel) connection, LED luminous color: WHITE.

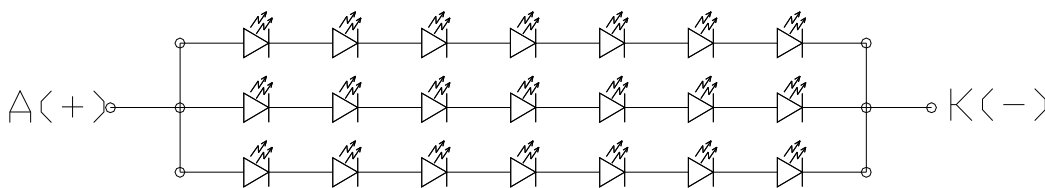



5.2 SIGNAL TIMING SPECIFICATIONS

ITEM		SYMBOL	min	typ	max	UNIT	
LCD	Frame Rate	-	-	60	-	Hz	
	Pixels Rate	-	156.8	156.8	159.9	MHz	
Timing	DCLK	Frequency	fCLK	490	490	498	MHz
		Period	Tclk	2.01	2.04	2.04	ns
	Horizontal	Horizontal total time	tHP	1343	1343	1368	t _{CLK}
		Horizontal Active time	tHadr	1200			t _{CLK}
		Horizontal Pulse Width	tHsync	1	1	1	t _{CLK}
		Horizontal Back Porch	tHBP	32	32	32	t _{CLK}
		Horizontal Front Porch	tHFP	110	110	133	t _{CLK}
	Vertical	Vertical total time	tvp	1946	1946	1951	t _H
		Vertical Active time	tVadr	1920			t _H
		Vertical Pulse Width	tVsync	1	1	1	t _H
		Vertical Back Porch	tVBP	14	14	14	t _H
		Vertical Front Porch	tVFP	11	11	16	t _H
	Differential Swing		VDswing	400	500	-	mV
	Bit Rate		TX SPD (Mbps)	980	980	995	Mbps
	Pixel Format			-	24	-	Data bit/pixel
Lane			-	4	-	Lane	

5.3 DC characteristics

Parameter	Symbol	Min	Typ	Max	Unit	Condition
MIPI digital operation current	I _{VCCIF}	-	-	24	mA	
MIPI digital stand-by current	I _{VCCIFST}	-	200	-	uA	
MIPI Characteristics for High Speed Receiver						
Single-ended input low voltage	V _{ILHS}	-40	-	-	mV	
Single-ended input high voltage	V _{IHHS}	-	-	460	mV	
Common-mode voltage	V _{CMRXDC}	155	-	330	mV	
Differential input impedance	Z _{ID}	80	100	125	Ω	
HS transmit differential voltage(V _{OD} =V _{OP} -V _{ON})	V _{OD}	85	200	250	mV	
MIPI Characteristics for Low Power Receiver						
Pad signal voltage range	V _I	-50	-	1350	mV	
Ground shift	V _{GNDSH}	-50	-	50	mV	
Output low level	V _{OL}	-150	-	150	mV	
Output high level	V _{OH}	1.1	1.2	1.3	V	

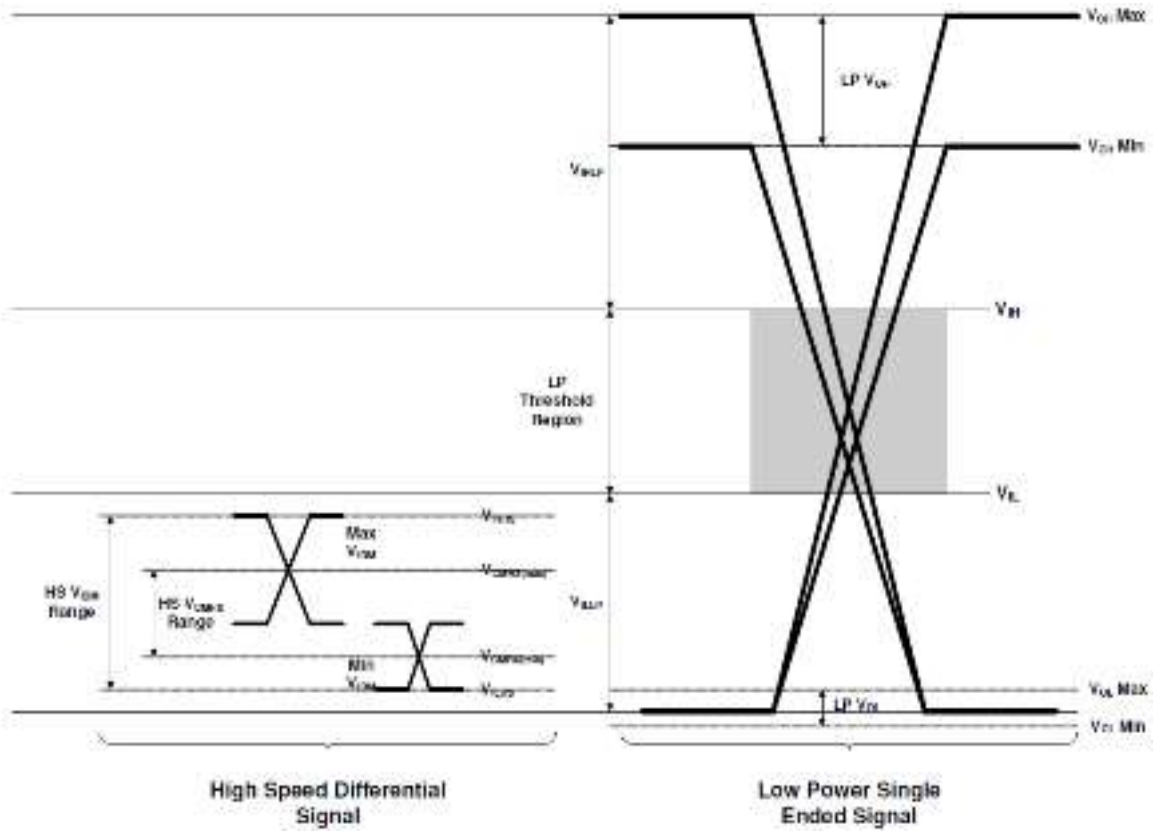

5.4 AC characteristics

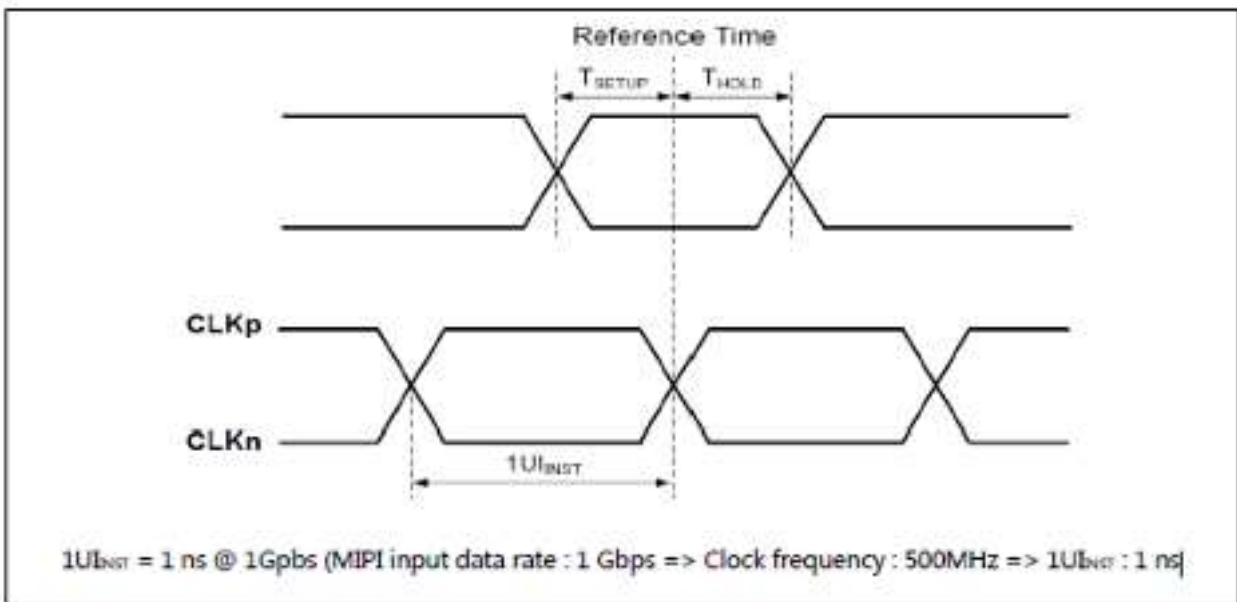

< Timing Diagram of MIPI Transmitter >

Description	Symbol	Condition	Min	Typ	Max	Unit
Data to Clock Setup Time	T_{setup}	-	0.25	-	-	UI_{BIST}
Clock to Data Hold Time	T_{hold}	-	0.25	-	-	UI_{BIST}



5.5 Power Sequence

(1) Power Sequence

To prevent a latch-up or DC operation of the LCD module, the power on/off sequence shall be as shown in below

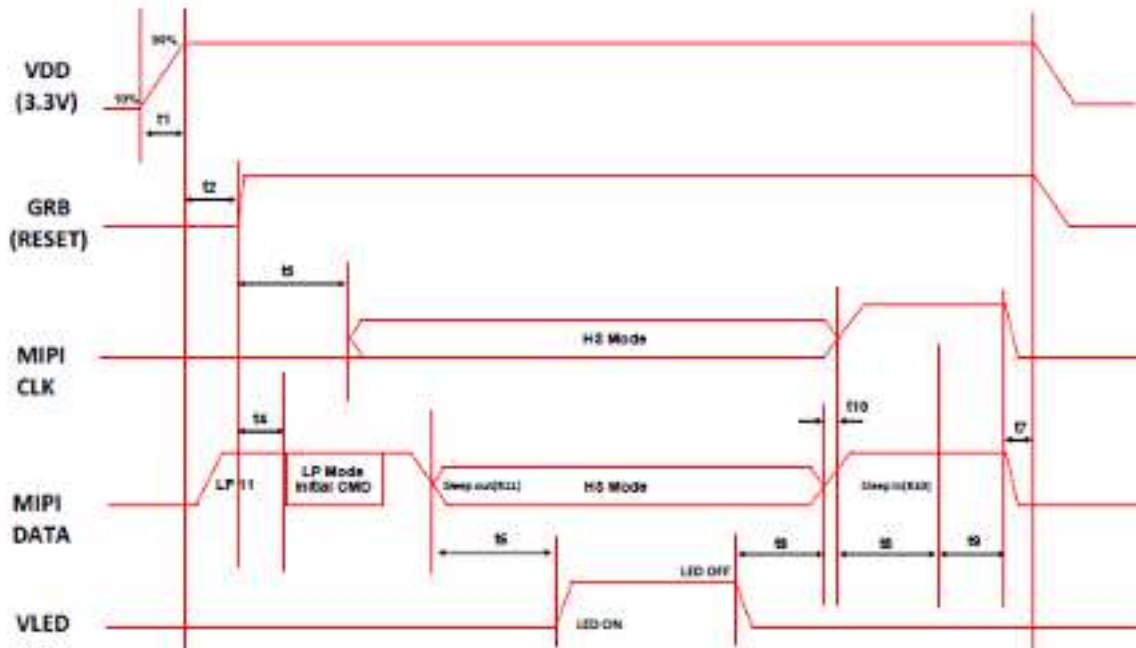

Item	Spec	Unit	Remark
t1	$t1 < 20$	ms	
t2	$t2 > 3$	ms	Source IC SPEC要求t2大于1ms,且因t2须大于t1-1 (为确保VDD1V6早于GRB(Reset)上电), 故建议t2设置大于3ms.
t3	$t3 < 50$	ms	
t4	$t4 > 0$	ms	
t5	$t5 \geq 200$	ms	
t6	$t6 \geq 50$	ms	
t7	$t7 \geq 0$	ms	
t8	$t8 > 150$	ms	Scan black(R10 后 IC固定跑4帧扫黑), t8以MIPI CLK拉LP11为参考
t9	$t9 > 70$	ms	
t10	$0 \leq t10 < 1$	frame	MIPI CLK与MIPI Data 拉LP11 时间差异小于1frame.



(2). Software Flow

Commands:

Normal display mode on = NORON

Idle mode off = IDMOFF

Idle mode on = IDMON

Sleep out = SLPOUT

Sleep in = SLPIN

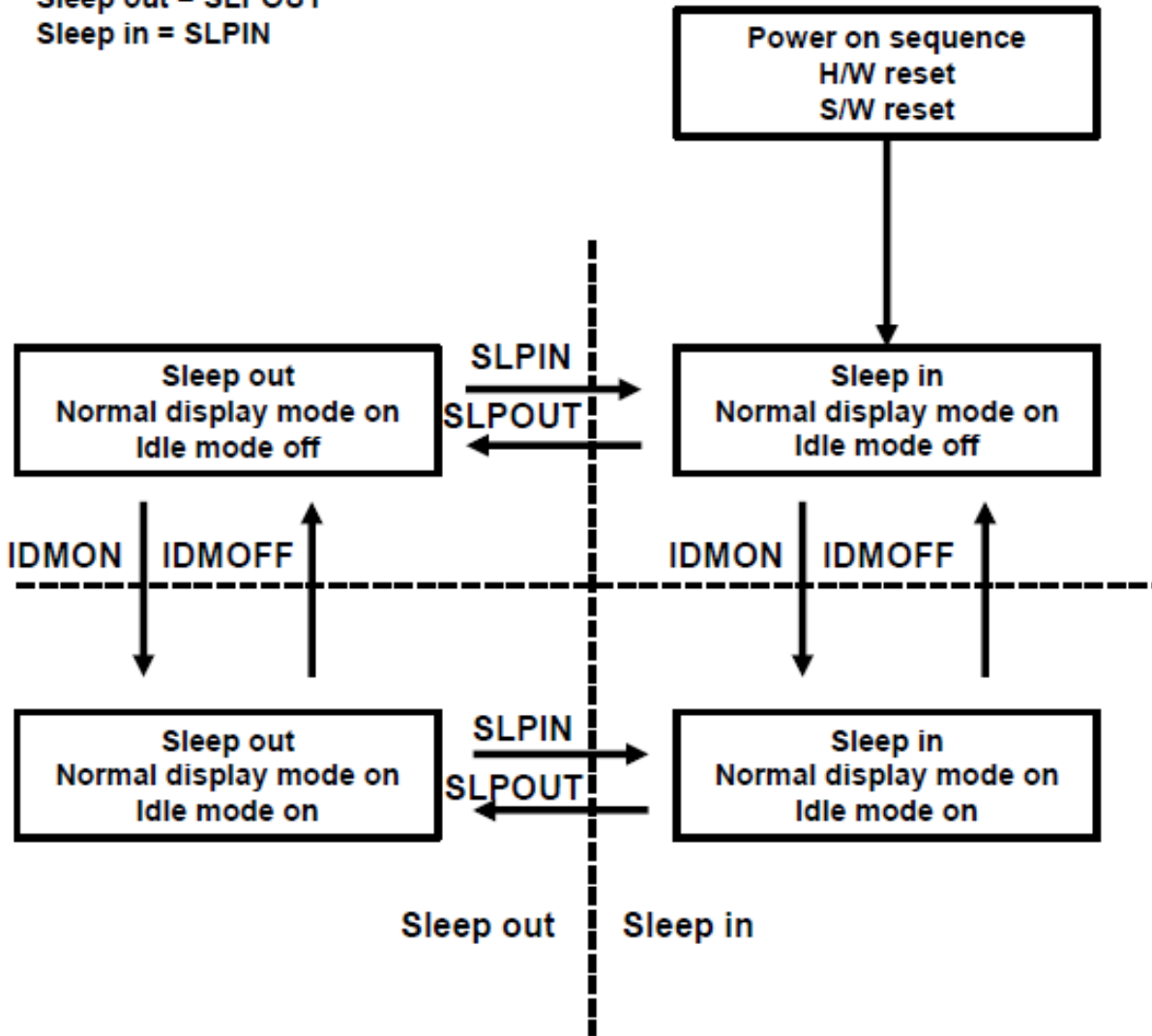



6. ELECTRO-OPTICAL CHARACTERISTICS

Item	Symbol	Condition	Min.	Typ.	Max.	Unit	Note
Brightness	Bp	$\Phi_1=0^\circ$	-	300	-	Cd/m ²	1
Uniformity	ΔBp	$\Phi_2=0^\circ$	80%				1,2
Viewing Angle	Φ_1 (up down)	$C_r \geq 10$	85typ			Deg	3
	Φ_2 (left right)		85typ				
Contrast Ratio	Cr	$\Theta=0$ Normal Viewing angle	-	1200	-	-	4
Response Time	Tr+Tf		-	-	35	ms	5
Color of CIE Coordinate	W	x	-0.02	0.302	+0.02	-	1,6
		y		0.319		-	
	R	x		0.641		-	
		y		0.34		-	
	G	x		0.307		-	
		y		0.611		-	
	B	x		0.151		-	
		y		0.053		-	
Color Gamut			65	70.8	-	%	



Note1 Definition of Contrast Ratio (CR):

$$\text{Contrast ratio (CR)} = \frac{\text{Luminance measured when LCD on the "White" state}}{\text{Luminance measured when LCD on the "Black" state}}$$

Note2: Definition of Luminance Uniformity: Active area is divided into 9 measuring areas (Shown in below), every measuring point is placed at the center of each measuring area.

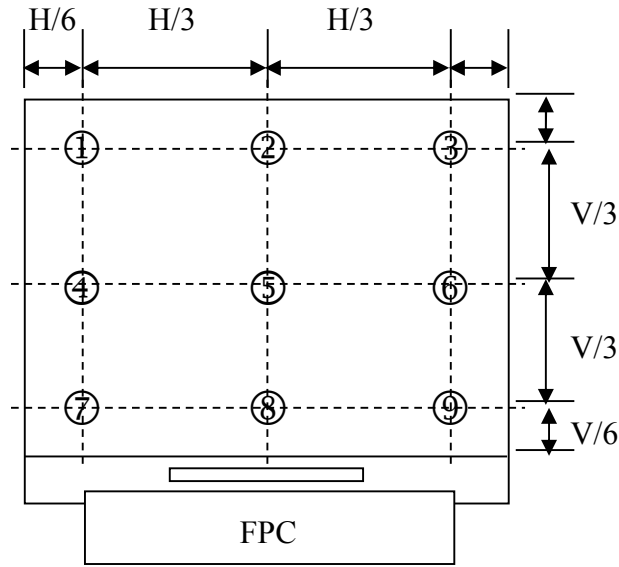

The spot locations for luminance measurement

$$\text{Luminance Uniformity} = \frac{H/6 B_{\min}}{V/6 B_{\max}} \times 100\%$$

B_{\max} : The measured maximum luminance of all measurement position.

B_{\min} : The measured minimum luminance of all measurement position.

Note 3: Definition of Response time: Sum of T_r and T_f

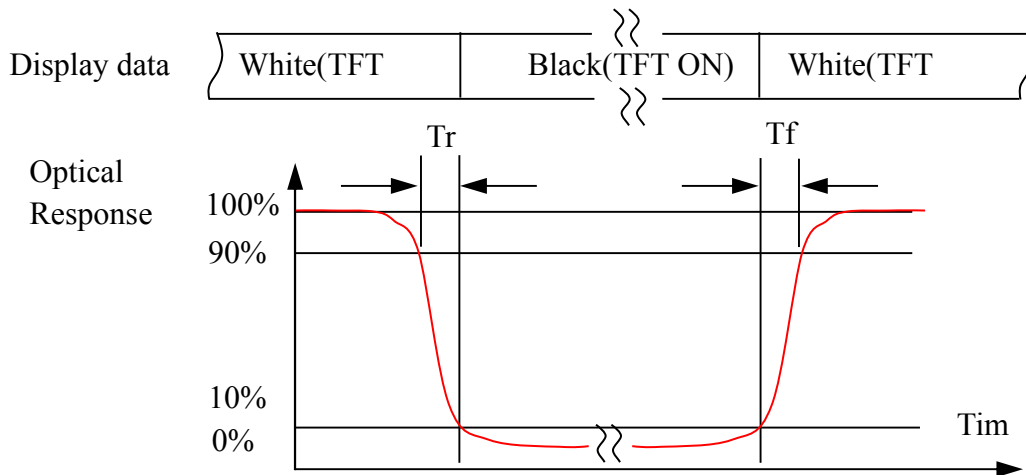



Note4. Definition of Viewing Angle: The viewing angle range that the $CR \geq 10$

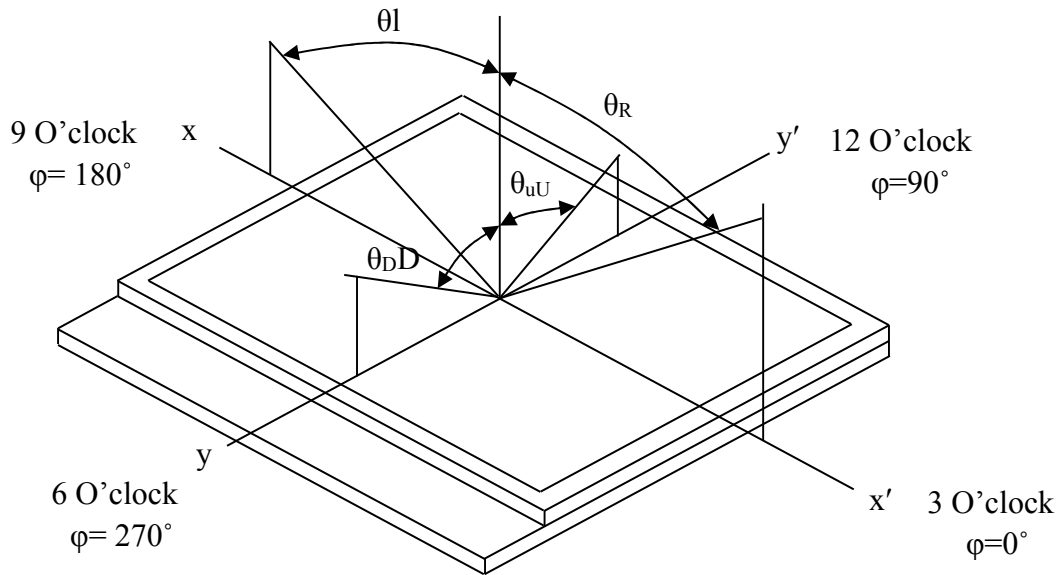

Note 5: Definition of Color Chromaticity (CIE 1931)

Color coordinate of white & red, green, blue at center point.



7. RELIABILITY TEST CONDITIONS

No	Test Item	Test Condition	STANDARD
1	High Temperature Storage	+70°C / 96Hours	1. Functional test is OK. Missing Segment, short, unclear segment, on-display, display abnormally and liquid crystal leak are un-allowed. 2. No low temperature bubbles, end seal loose and fall, frame rainbow.
2	Low Temperature Storage	-30°C / 96Hours	
3	High Temperature Operating	+60°C / 96Hours	
4	Low Temperature Operating	-20°C / 96Hours	
5	Thermal and cold shock	0°C↔+50°C x 10cycles (30min) (5min) (30min)	
6	Operate at High Temperature and Humidity	60°C x 90%RH / 24H	1. Function test is OK. 2. No glass crack, chipped glass, end seal loose and fall, epoxy frame crack and so on. 3. No structure loose and fall.
7	Vibration Test	TBD	
8	Dropping test	TBD	The test results shall be subject to the whole machine test.
9	ESD test	Contact: ±6KV Air: ±8KV 150PF/330Ω,5Points/panel,5times	

NOTE:

1. The reliability items will be fully performed in new sample qualification,
2. The reliability status will be tested as monitor during mass production. Individual reliability test shall be performed by lot, Moreover, the individual reliability item shall be decided according to reliability plan.
3. All samples are inspected after keeping in the room with normal temperature and humidity for 2 hours or above.
4. Vibration test: It is not necessary to test for those products without assembly frame, backlight, PCB and so on.
5. Dropping test: It is necessary for affirming new package.
6. For the high temperature and high humidity test, pure water of over 10 MΩ.cm should be used.
7. Each test item applies for test LCM only once. Then tested LCM cannot be used again in any other test item.
8. The quantity of LCM examination for each test item is 5pcs to 10pcs.



8. INSPECTION STANDARDS

8.1 AQL Sampling inspection standard

使用 GB/T 2828-2003 一般 II 水平, 采用正常检查一次抽样方式; 具体抽检方式参照《成品检验管理程序》、《抽样管理规范》

缺陷区分	AQL 允收水准
严重缺陷	0 收 1 退
重缺	0.4
轻缺	1.0

8.2 Inspect the condition

8.2.1 在 20—40W 日光灯的照明条件下, 样品离检查者眼睛约 30cm 处进行检查。检验方向以垂直线前后左右 45° (以时钟 3 点、6 点、9 点、12 点)

8.2.2 检验者视力需达到标准视力 1.0 以上。

8.2.3 检验者需戴静电手环、两手八个手指套。

8.2.4 外观检验者以目视检查或以菲林对比卡比对。

8.2.5 电性测试使用电测测架, 主板, 电源线及单片机。

8.2.6 若标准与规格书不符时, 以产品发行之规格书特殊检验规格、工程变更为准

8.2.7 辉色度检测请参照样品, 检测方法依照辉色度检验标准。

8.2.8 电测检验环境: 照度为 200LUX 以下, 外观检验环境: 照度为 600LUX-1000LUX, 检验时间: 1 秒-3 秒。

8.2.9 检验工具: 电测测架, 主板, 电源线及单片机, 菲林对比卡, 游标卡尺, 放大镜, 实体显微镜 (必要时) 等等。

8.3 Judgment criterion

小尺寸点、线判定标准: (6.2 寸以内)

1	点状缺陷 (磨伤、异物、针孔、凹痕、缺膜、气泡、白点、彩点、脏点)		判定 (A/B/C 区)	$D \leq 0.10$, 忽略不计, 但密集型不允许	MI	OK
				$0.1 < D \leq 0.15$, $ds \geq 10$		$N \leq 2$
				$0.15 < D \leq 0.2$, $ds \geq 10$		$N \leq 1$
				LCD 亮点: $0.15 < D$		$N \leq 1$
				$D > 0.2$		NG
			判定 (D 区)	同背面丝印油墨区杂质判定标准		
			注: 1) D 区的点状缺陷需在不影响 CTP 功能、客户组装及整机的外观的情况下, 判定 OK		MI	
2	线状缺陷 (磨伤、无感划伤、毛屑、纤维等)		判定 (A/B/C 区)	$W \leq 0.03mm$, $L \leq 3mm$, $ds \geq 10$	MI	$N \leq 2$
				$0.03mm < W \leq 0.05mm$, $L \leq 3mm$, $ds \geq 10$		$N \leq 1$
				$W > 0.05mm$ 或 $L > 3mm$		NG



中尺寸点、线判定标准：（6.2~8寸以内）

1	点状缺陷 (磨伤、异物、针孔、凹痕、缺膜、气泡、白点、彩点、脏点)		判定(A/B/C区)	$D \leq 0.10$, 忽略不计, 但密集型不允许	MI	OK	
				$0.15 < D \leq 0.25$, $ds \geq 10$		$N \leq 2$	
				$0.25 < D \leq 3$, $ds \geq 10$		$N \leq 1$	
				LCD亮点: $0.2 < D$		$N \leq 1$	
				$D > 0.3$		NG	
			判定(D区)	同背面丝印油墨区杂质判定标准			
			注: 1) D区的点状缺陷需在不影响CTP功能、客户组装及整机的外观的情况下, 判定OK			MI	
2	线状缺陷 (磨伤、无感划伤、毛屑、纤维等)		判定(A/B/C区)	$W \leq 0.03mm$, $L \leq 3mm$, $ds \geq 10$	MI	$N \leq 2$	
				$0.03mm < W \leq 0.05mm$, $L \leq 3mm$, $ds \geq 10$		$N \leq 1$	
				$W > 0.05mm$ 或 $L > 3mm$		NG	

大尺寸点、线判定标准：（8.1~13.3寸以内）

1	点状缺陷 (磨伤、异物、针孔、凹痕、缺膜、气泡、白点、彩点、脏点)		判定(A/B/C区)	$D \leq 0.1$, 忽略不计, 但密集型不允许	MI	OK	
				$0.15 < D \leq 0.3$, $ds \geq 10$		$N \leq 2$	
				$0.3 < D \leq 0.35$, $ds \geq 10$		$N \leq 1$	
				LCD亮点: $0.25 < D$		$N \leq 1$	
				$D > 0.35$		NG	
			判定(D区)	同背面丝印油墨区杂质判定标准			
			注: 1) D区的点状缺陷需在不影响CTP功能、客户组装及整机的外观的情况下, 判定OK			MI	
2	线状缺陷 (磨伤、无感划伤、毛屑、纤维等)		判定(A/B/C区)	$W \leq 0.05mm$, $L \leq 5mm$, $ds \geq 10$	MI	$N \leq 2$	
				$0.05mm < W \leq 0.07mm$, $L \leq 5mm$, $ds \geq 10$		$N \leq 1$	
				$W > 0.07mm$ 或 $L > 5mm$		NG	



9. PACKAGE DRAWING

LCM产品(刀卡类)包装流程图

1.0 包装材料清单:

见受控BOM

2.0 包装方法说明:

LCM产品

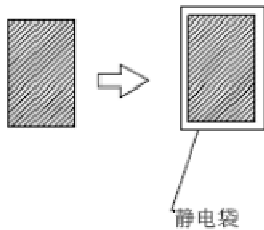

第一步:
LCM产品装入静电袋

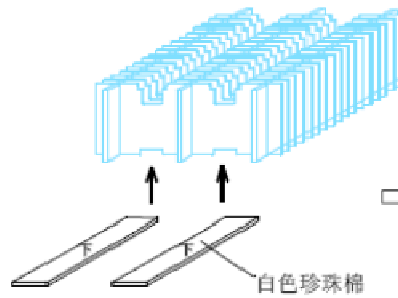

第二步:
把长卡, 短卡组成卡阵 (短卡朝向一致)
形状和数量按照 BOM 实际物料
卡阵底部放对应的白色珍珠棉后装箱

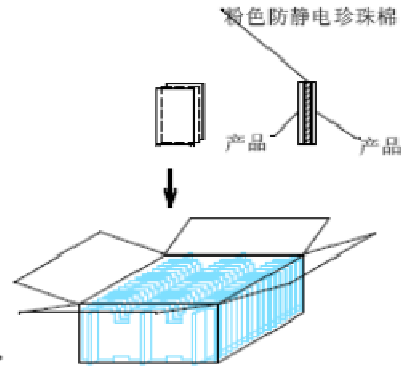

第三步:
放产品, 每个卡槽内放两片产品;
2PCS 产品显示面相对,
中间加粉色珍珠棉一起放入卡槽内。

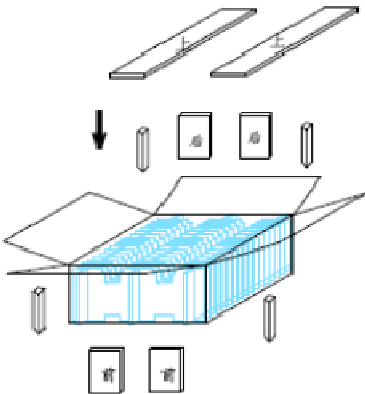

第四步:
装箱后, 按照BOM实际物料在纸箱内
侧与卡阵避空位置放白色泡棉:

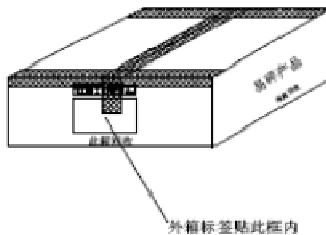

第五步:
最后胶带封箱, 贴外箱标签

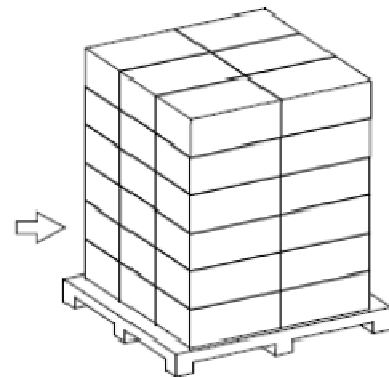

第六步:
将每箱整齐摆放在栈板上并包裹
最高可堆叠6层