



SPECIFICATION FOR TFT LCD MODULE

CUSTOMER : _____

CUSTOMER MODULE : _____

HL MODEL : HG101WU035

Preliminary Specification

Final Specification

Customer Confirmation column:

Approved by : _____ Dept. : _____ Data : _____

Please return one of the copies of the specification with your signature to us within two weeks after you receive this document. If it is not returned, we will assume that you agree to the entire contents of this specification document.

Designed by	Checked by	Approved by



Contents

1. Operating Precautions	3
2. General Description	4
2.1 Display Characteristics	4
2.2 Optical Characteristics	5
3. Functional Block Diagram	8
4. Absolute Maximum Ratings.....	9
4.1 Absolute Ratings of TFT LCD Module.....	9
4.2 Absolute Ratings of Environment.....	9
5. Electrical Characteristics.....	10
5.1 TFT LCD Module	10
5.2 Backlight Unit.....	13
6. Signal Characteristic.....	14
6.1 Pixel Format Image.....	14
6.2 Signal Description	15
6.3 The Input Data Format.....	16
6.4 Interface Timing	17
6.5 Power ON/OFF Sequence	18
7. Reliability Test Criteria.....	19
8. Mechanical Characteristics	20
8.1 Outline Dimension (Front View)	20
8.2 Outline Dimension (Rear View).....	21
9. Label and Packaging.....	22
9.1 Shipping Label (on the rear side of TFT-LCD display).....	22
9.2 Carton/Pallet Package	22
10 Safety.....	23
10.1 Sharp Edge Requirements.....	23
10.2 Materials	23
10.3 Capacitors.....	23
10.4 National Test Lab Requirement.....	23



1. Operating Precautions

- 1) Since front polarizer is easily damaged, please be cautious and not to scratch it.
- 2) Be sure to turn off power supply when inserting or disconnecting from input connector.
- 3) Wipe off water drop immediately. Long contact with water may cause discoloration or spots.
- 4) When the panel surface is soiled, wipe it with absorbent cotton or soft cloth.
- 5) Since the panel is made of glass, it may be broken or cracked if dropped or bumped on hard surface.
- 6) To avoid ESD (Electro Static Discharge) damage, be sure to ground yourself before handling TFT-LCD Module.
- 7) Do not open nor modify the module assembly.
- 8) Do not press the reflector sheet at the back of the module to any direction.
- 9) In case if a module has to be put back into the packing container slot after it was taken out from the container, do not press the center of the LED light bar edge. Instead, press at the far ends of the LED light bar edge softly. Otherwise the TFT Module may be damaged.
- 10) At the insertion or removal of the Signal Interface Connector, be sure not to rotate nor tilt the Interface Connector of the TFT Module.
- 11) TFT-LCD Module is not allowed to be twisted & bent even force is added on module in a very short time. Please design your display product well to avoid external force applying to module by end-user directly.
- 12) Small amount of materials having no flammability grade is used in the LCD module. The LCD module should be supplied by power complied with requirements of Limited Power Source (IEC60950 or UL1950), or be applied exemption.
- 13) Severe temperature condition may result in different luminance, response time and lamp ignition voltage.
- 14) Continuous operating TFT-LCD display under low temperature environment may accelerate lamp exhaustion and reduce luminance dramatically.
- 15) The data on this specification sheet is applicable when LCD module is placed in landscape position.
- 16) Continuous displaying fixed pattern may induce image sticking. It's recommended to use screen saver or shuffle content periodically if fixed pattern is displayed on the screen.
- 17) In order not to damage the touch panel, please remove the protected film as slow as possible in an environment with a humidity range from 60% to 80%



2. General Description

HG101WU035 is a Color Active Matrix Liquid Crystal Display composed of a TFT LCD panel and LED backlight system. The screen format is intended to support the 16:10 WUXGA, 1920(H) x 1200(V) screen and 16.7M colors (RGB 6-bits + Hi-FRC) with LED backlight driving circuit. All input signals are eDP 1.2 interface compatible.

2.1 Display Characteristics

The following items are characteristics summary under 25 °C condition:

Items	Unit	Specifications
Screen Diagonal	[inch]	10.1"
Active Area	[mm]	216.81(H) x 135.5(V)
Pixels H x V		1920 x 1200
Pixel Pitch	[mm]	0.11292 X 0.11292
Pixel Arrangement		R.G.B. Vertical Stripe
Display Mode		AHVA, Normally Black
Nominal Input Voltage VDD	[Volt]	3.3 (Typical)
Power Consumption	[Watt]	2.37 (Max)
Weight (Max.)	[Grams]	140g
Physical Size (Max.)	[mm]	228.22 x 148.32 x 5.35
Electrical Interface		eDP1.2
Surface Treatment		HCLR
Support Color		16.7M colors (RGB 6-bit + Hi-FRC)
Temperature Range Operating Storage (Non-Operating)	[°C] [°C]	-20 to +60 (Front and rear surface) -30 to +70
RoHS Compliance		RoHS Compliance



2.2 Optical Characteristics

The optical characteristics are measured under stable conditions at 25 °C (Room Temperature):

Item	Unit	Conditions	Min.	Typ.	Max.	Note
White Luminance	[cd/m ²]	I _{LED} = 19.6mA (5p average)	350	410	---	
Uniformity	%	5 points	70%		---	
Contrast Ratio			600	800	---	
Response Time	[msec]	Rising + Falling	---	25	35	
Viewing Angle	[degree]	Horizontal (Right)	80	85	---	
	[degree]	CR = 10 (Left)	80	85	---	
	[degree]	Vertical (Upper)	80	85	---	
	[degree]	CR = 10 (Lower)	80	85	---	
Color / Chromaticity Coordinates (CIE 1931)		Red x	0.543	0.593	0.643	
		Red y	0.291	0.341	0.391	
		Green x	0.292	0.342	0.392	
		Green y	0.539	0.589	0.639	
		Blue x	0.104	0.154	0.204	
		Blue y	0.073	0.123	0.173	
		White x	0.263	0.313	0.363	
		White y	0.279	0.329	0.379	
Color Gamut	%		---	50	---	

Note 1: Measurement method

Equipment Pattern Generator, Power Supply, Digital Voltmeter, Luminance meter (SR_3 or equivalent)

Aperture Field angle 2□ with 50cm measuring distance

Test Point Follow Note 2 position

Environment < 1 lux

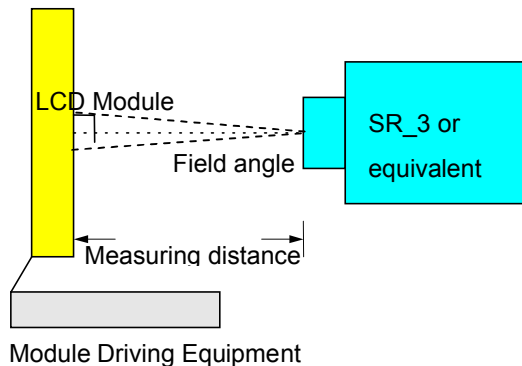



Note 2: Definition of 5 points position

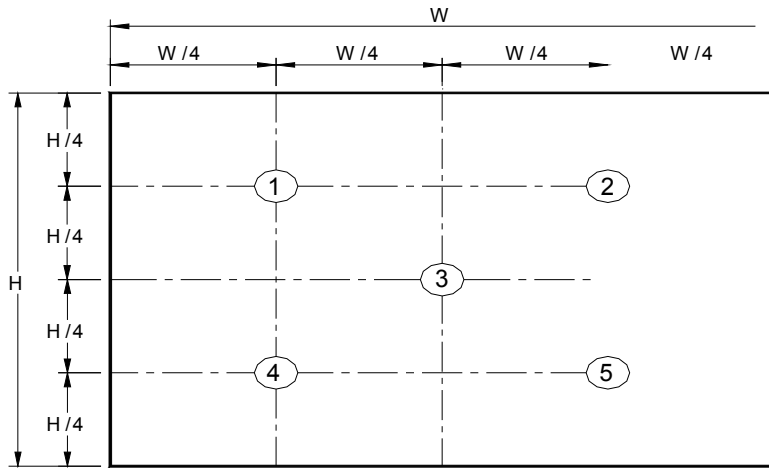

Note 3: The luminance uniformity of 5 points is defined by dividing the minimum luminance values by the maximum test point luminance

$$\delta_{w5} = \frac{\text{Minimum Brightness of five points}}{\text{Maximum Brightness of five points}}$$

Note 4: Definition of contrast ratio (CR):

$$\text{Contrast ratio (CR)} = \frac{\text{Brightness on the "White" state}}{\text{Brightness on the "Black" state}}$$

Note 5: Definition of response time:

The output signals of photo detector are measured when the input signals are changed from "White" to "Black" (falling time) and from "Black" to "White" (rising time), respectively. The response time interval is between 10% and 90% of amplitudes. Please refer to the figure as below.

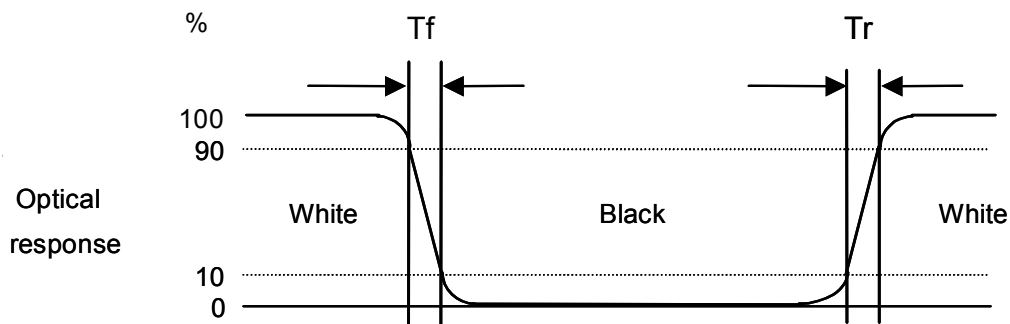



Note 6: Definition of viewing angle

Viewing angle is the measurement of contrast ratio ≥ 10 , at the screen center, over a 180° horizontal and 180° vertical range (off-normal viewing angles). The 180° viewing angle range is broken down as below: 90° (θ) horizontal left and right, and 90° (Φ) vertical high (up) and low (down). The measurement direction is typically perpendicular to the display surface with the screen rotated to its center to develop the desired measurement viewing angle.

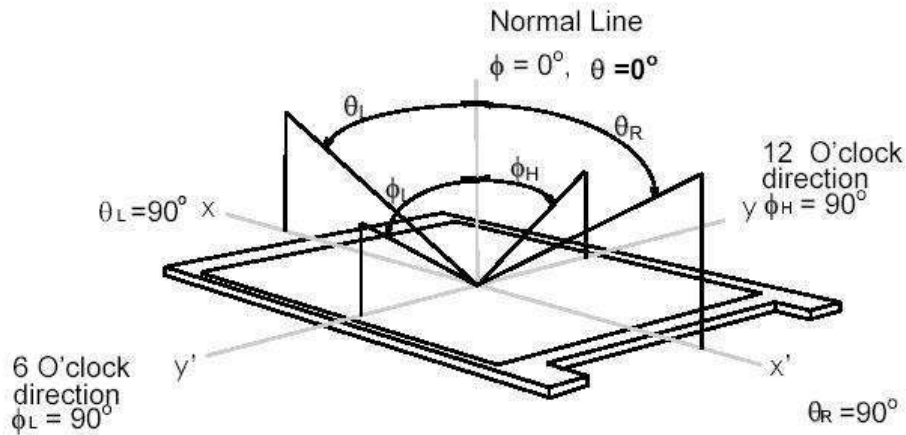



3. Functional Block Diagram

The following diagram shows the functional block of the 10.1 inch color TFT/LCD module:

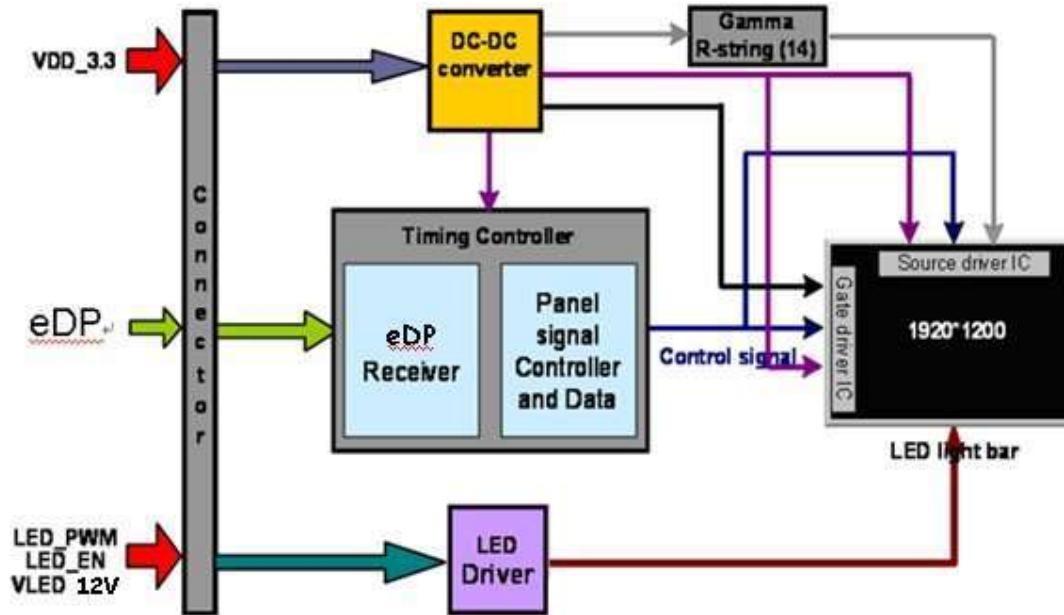



4. Absolute Maximum Ratings

4.1 Absolute Ratings of TFT LCD Module

Item	Symbol	Min	Max	Unit
Logic/LCD drive Voltage	VDD	-0.3	+4.0	[Volt]
LCD Input Signal Voltage	V _{SIGNAL}	-0.3	VDD+0.3	[Volt]

4.2 Absolute Ratings of Environment

Item	Symbol	Min	Max	Unit
Operating Temperature	TOP	-20	+60	[°C]
Humidity	HOP	5	90	[%RH]
Storage Temperature	TST	-30	+70	[°C]
Storage Humidity	HST	5	90	[%RH]

Note 1: At Ta (25°C)

Note 2: Permanent damage to the device may occur if exceed maximum values

Note 3: Maximum wet-bulb temperature is less than 39 oC and no condensation

Note 4: Operating temperature means “Front and rear surface” of panel



5. Electrical Characteristics

5.1 TFT LCD Module

5.1.1 Power Specification

The power specification are measured under 25°C and frame frequency under 60Hz

Symbol	Parameter	Min	Typ	Max	Units	Remark
VDD	Logic/LCD Drive Voltage	3.0	3.3	3.6	[Volt]	
IDD	VDD Current	-	200	240	[mA]	All White Pattern (VDD=3.3V, at 60Hz)
Irush	LCD Inrush Current	-	-	1500	[mA]	Note 2
PDD	VDD Power	-	0.66	0.79	[Watt]	All White Pattern (VDD=3.3V, at 60Hz)
VDDrp	Allowable Logic/LCD Drive Ripple Voltage	-	-	100	[mV] p-p	All White Pattern (VDD=3.3V, at 60Hz)

Note 1 : Maximum Measurement Condition : White Pattern at 3.3V driving voltage. ($P_{max}=V_{3.3} \times I_{white}$)

Note 2 : Measure Condition

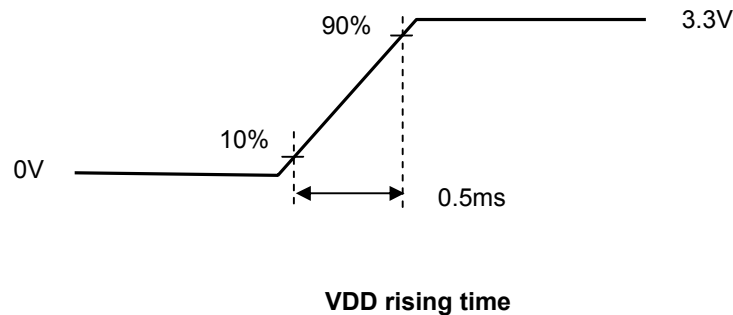



5.1.2 Signal Electrical Characteristics

Signal electrical characteristics are as follows:

Display Port main link signal:

Differential pair VD+ , VD-
Which is one Display port
Main link

VCM of Display port
Main link

$$V_{diffP-P} = [(VD+) - (VD-)] \times 2$$

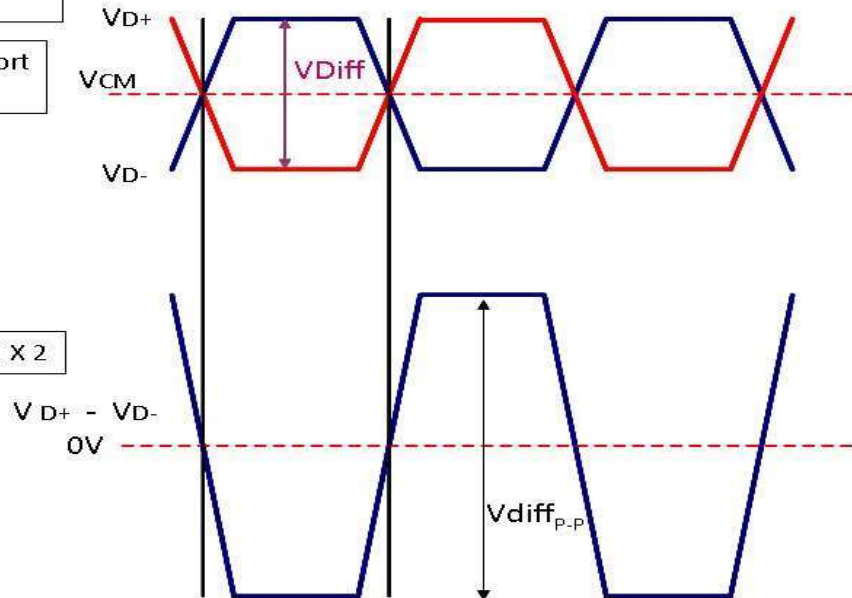

Display port main link					
		Min	Typ	Max	unit
VCM	RX input DC Common Mode Voltage		0		V
VDiff _{P-P}	Peak-to-peak Voltage at a receiving Device	150		1320	mV

Follow as VESA display port standard V1.1a

Display Port AUX_CH signal:

Differential AUX+ , AUX-
Which is Display pot AUX_CH

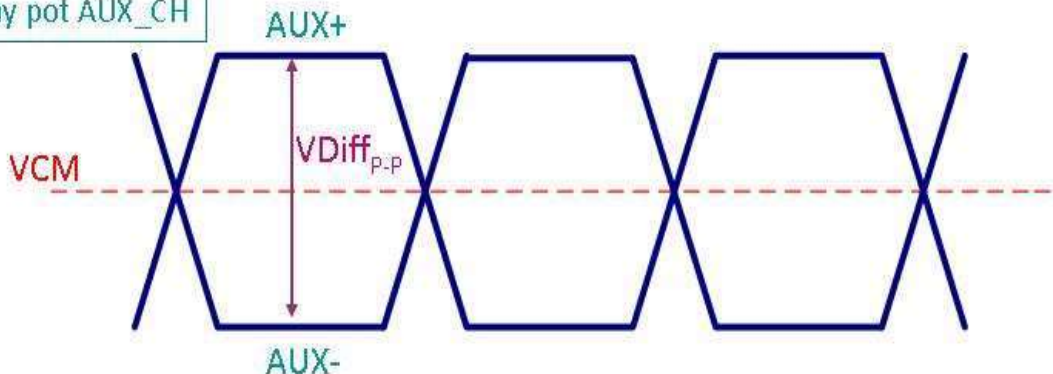



Display port AUX_CH					
		Min	Typ	Max	unit
VCM	AUX DC Common Mode Voltage		0		V
VDiff _{P-P}	AUX Peak-to-peak Voltage at a receiving Device	0.4	0.6-	0.8	V

Follow as VESA display port standard V1.1a.

Display Port VHPD signal:

Display port VHPD					
		Min	Typ	Max	unit
VHPD	HPD Voltage	2.25	-	2.75	V

Follow as VESA display port standard V1.1a.



5.2 Backlight Unit

5.2.1 Parameter guideline for LED

Following characteristics are measured under a stable condition using an inverter at 25°C (Room Temperature):

Symbol	Parameter	Min.	Typ.	Max.	Unit	Remark
VLED	Input Voltage	10.8	12	13.2	[Volt]	
I _{VLED}	Input Current	---	110	132	[mA]	100% Brightness (VLED = 12V)
P _{VLED}	Power Consumption	---	1.32	1.58	[Watt]	100% Brightness (VLED = 12V)
I _F	LED Forward Current	---	19.6	---	[mA]	Ta = 25°C
VEN	LED Enable Input High Level	1.8	-	5.5	[Volt]	
	LED Enable Input Low Level	-	-	0.8	[Volt]	
VPWM	PWM Logic Input High Level	1.8	-	5.5	[Volt]	
	PWM Logic Input Low Level	-	-	0.8	[Volt]	
Operation Life	---	20,000	30,000	---	Hrs	(Ta=25°C), Note 2 I _F =19.6mA

Note 1: Ta means ambient temperature of TFT-LCD module.

Note 2: V_{LED}, I_{VLED}, P_{VLED} are defined for LED backlight.(100% duty of PWM dimming)

Note 3: If G101UAN01.0 module is driven by high current or at high ambient temperature & humidity condition. The operating life will be reduced.

Note 4: Operating life means brightness goes down to 50% initial brightness. Minimum operating life time is estimated data.



6. Signal Characteristic

6.1 Pixel Format Image

Following figure shows the relationship between input signal and LCD pixel format.

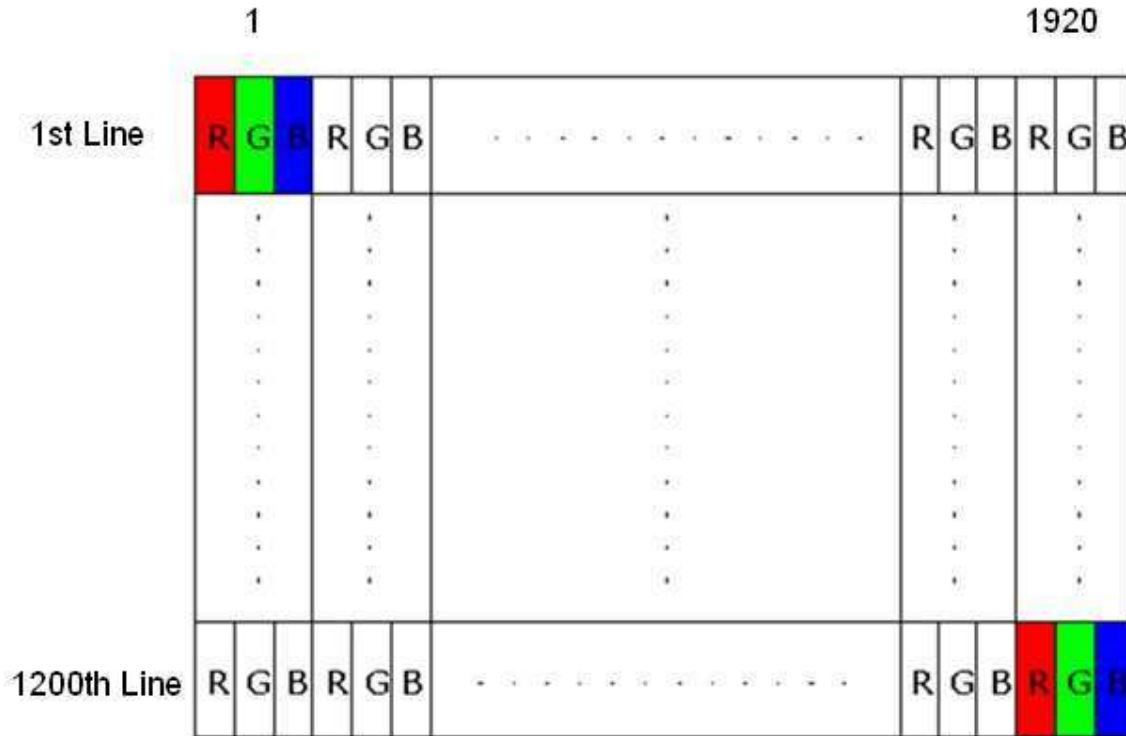



6.2 Signal Description

The module uses a eDP1.2 receiver embedded in AUO's ASIC. eDP 1.2 is a differential signal technology for LCD interface and a high-speed data transfer device.

6.2.1 eDP Connector Description

Physical interface is described as for the connector on module.

These connectors are capable of accommodating the following signals and will be following components.

Connector Name / Designation	For Signal Connector
Manufacturer	IPEX or compatible
Type / Part Number	IPEX 20455-030E-12 or compatible
Mating Housing/Part Number	IPEX 20455-030T-11 or compatible

6.2.2 Pin Assignment

PIN NO	Symbol	Function
1	NC	No Connect
2	H_GND	High Speed Ground
3	Lane 1_N	NC
4	Lane 1_P	NC
5	H_GND	High Speed Ground
6	Lane0_N	Comp Signal Link Lane 0
7	Lane0_P	True Signal Link Lane 0
8	H_GND	High Speed Ground
9	AUX_CH_P	True Signal Auxilliary Ch.
10	AUX_CH_N	Comp Signal Auxilliary Ch.
11	H_GND	High Speed Ground
12	VDD_C	LCD logic and driver power
13	VDD_L	LCD logic and driver power
14	NC	No connect
15	LCD_GND	LCD logic and driver ground
16	LCD_GND	LCD logic and driver ground
17	HPD	HPD signale pin
18	BL_GND	Backlight_ground
19	BL_GND	Backlight_ground
20	BL_GND	Backlight_ground
21	BL_GND	Backlight_ground
22	VEN	Backlight On / Off
23	VPWM	System PWM signal Input
24	NC	No connect
25	NC	No connect
26	V_LED	Backlight power (10.8V~13.2V)
27	V_LED	Backlight power (10.8V~13.2V)
28	V_LED	Backlight power (10.8V~13.2V)
29	V_LED	Backlight power (10.8V~13.2V)
30	NC	No Connect



6.3 The Input Data Format

Input Pixel Stream Format (1920RGB in 4 Lanes with RGB 8-8-8 format)

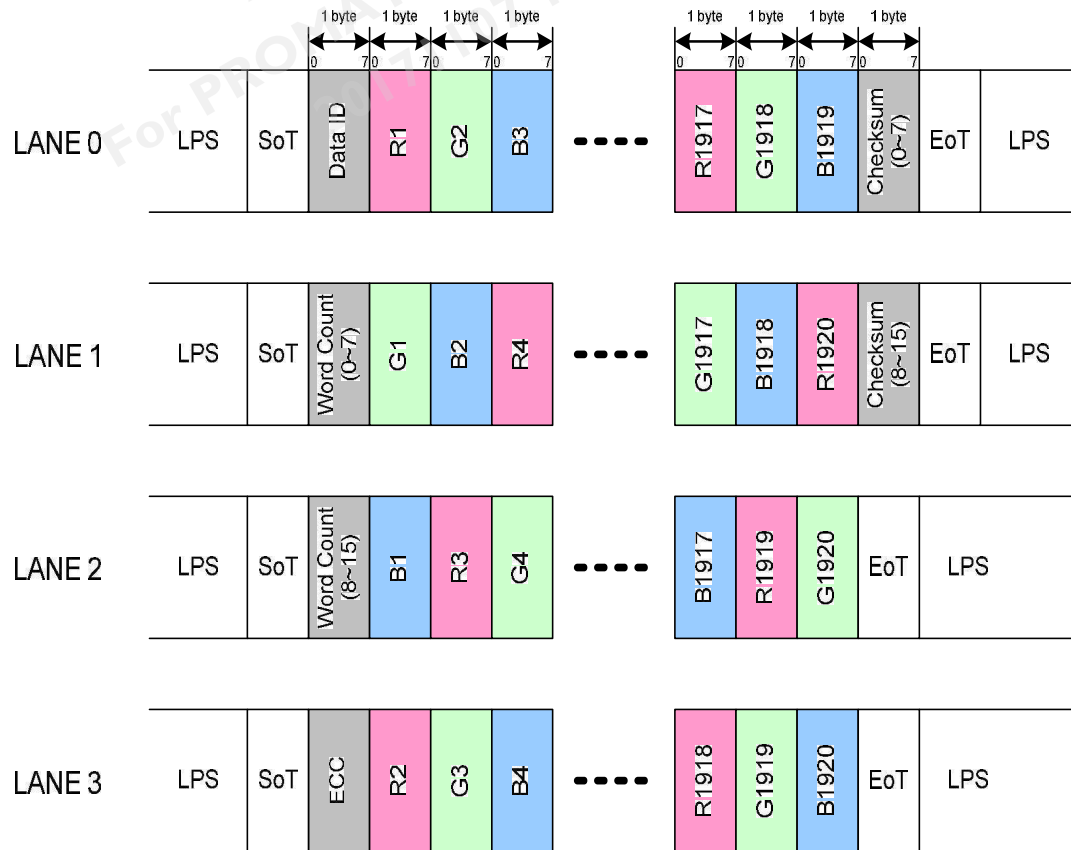

LPS : Low Power State
SoT : Start of Transmission
EoT : End of Transmission
ECC : Error-Correcting Code



6.4 Interface Timing

6.4.1 Timing Characteristics

Signal	Symbol	Min.	Typ.	Max.	Unit	
Clock Frequency	$1/T_{\text{Clock}}$	155.43	157.08	158.73	MHz	
Vertical Section	Period	T_V	1206	1212	1218	T_{Line}
	Active	T_{VD}	1200			
	Blanking	T_{VB}	6	12	18	
Horizontal Section	Period	T_H	2148	2160	2172	T_{Clock}
	Active	T_{HD}	1920			
	Blanking	T_{HB}	228	240	252	
Frame Rate	F	---	60	---	Hz	

Note : DE mode.

6.4.2 Input Timing Diagram

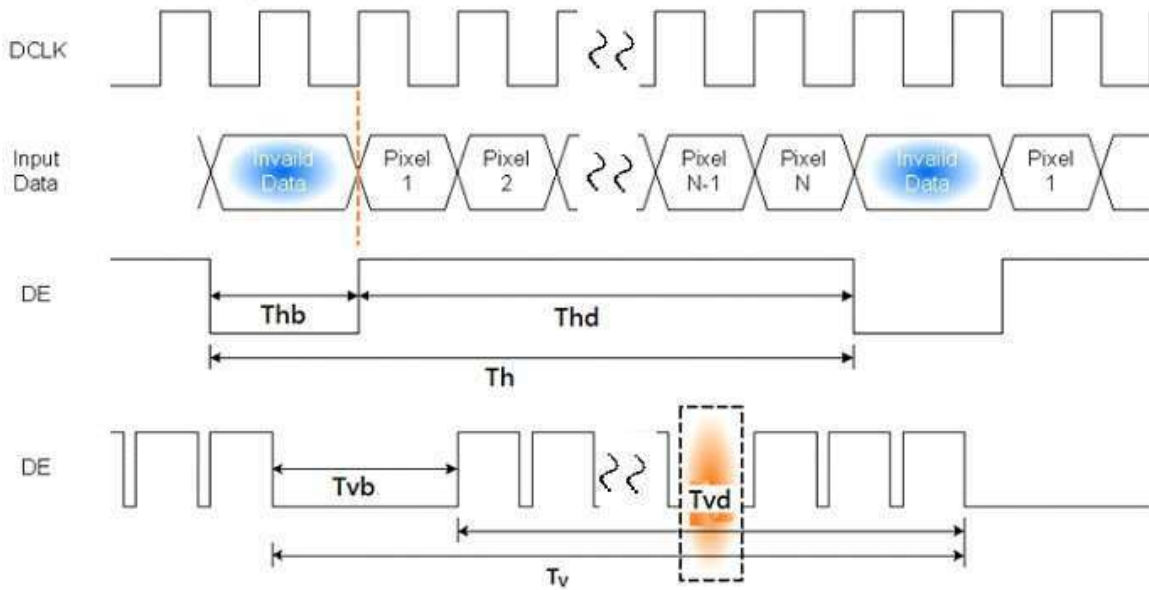



6.5 Power ON/OFF Sequence

VDD power and lamp on/off sequence is as below. Interface signals are also shown in the chart. Signals from any system shall be Hi-Z state or low level when VDD is off.

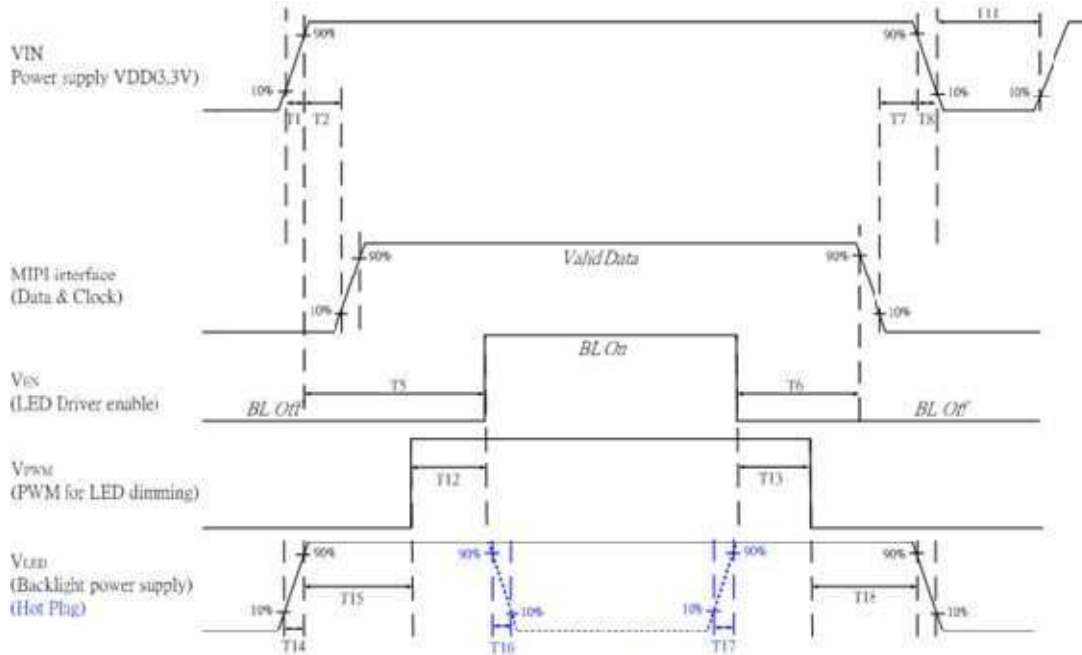

Power Sequence Timing			
Parameter	Value		Units
	Min.	Max.	
T1	0.5	10	Ms
T2	0	50	
T5	200	-	
T6	200	-	
T7	0	50	
T8	0	10	
T11	500	-	
T12	10	-	
T13	10	-	
T14	0.5	10	
T15	10	-	
T16	1	-	
T17	1	-	
T18	10	-	

Note: VPWM must be pull low(GND) when it is not pull high.



7. Reliability Test Criteria

Items	Required Condition	Note
Temperature Humidity Bias	40 °C /90%,300Hr	
High Temperature Operation	60 °C, 300Hr (center point of panel surface)	
Low Temperature Operation	-20 °C, 300Hr	
Hot Storage	70 °C, 300Hr	
Cold Storage	-30 °C, 300Hr	
Thermal Shock Test	-20 °C /30 min , 60 °C /30 min , 20cycles	
Hot Start Test	60 °C /1 Hr min. power on/off per 5 minutes, 5 times	
Cold Start Test	-20 °C /1 Hr min. power on/off per 5 minutes, 5 times	
On/off test	On/10 sec, Off/10 sec, 30,000 cycles	
ESD	Contact : ± 8KV/ operation, Class B Air : ± 15KV / operation, Class B	Note 1
Shock test	220G,2ms, Half-sine wave, 1 times for each direction (±X, ±Y, ±Z), non-operation	
Vibration test	1.5G, (10~500Hz, random), 30 mins / axis (X, Y, Z), non-operation	

Note1: According to EN61000-4-2 , ESD class B: Some performance degradation allowed. No data lost
. Self-recoverable. No hardware failures.

Note2:

- Water condensation is not allowed for each test items.
- Each test is done by new TFT-LCD module. Don't use the same TFT-LCD module repeatedly for reliability test.
- The reliability test is performed only to examine the TFT-LCD module capability.
- To inspect TFT-LCD module after reliability test, please store it at room temperature and room humidity for 24 hours at least in advance.



8. Mechanical Characteristics

8.1 Outline Dimension (Front View)

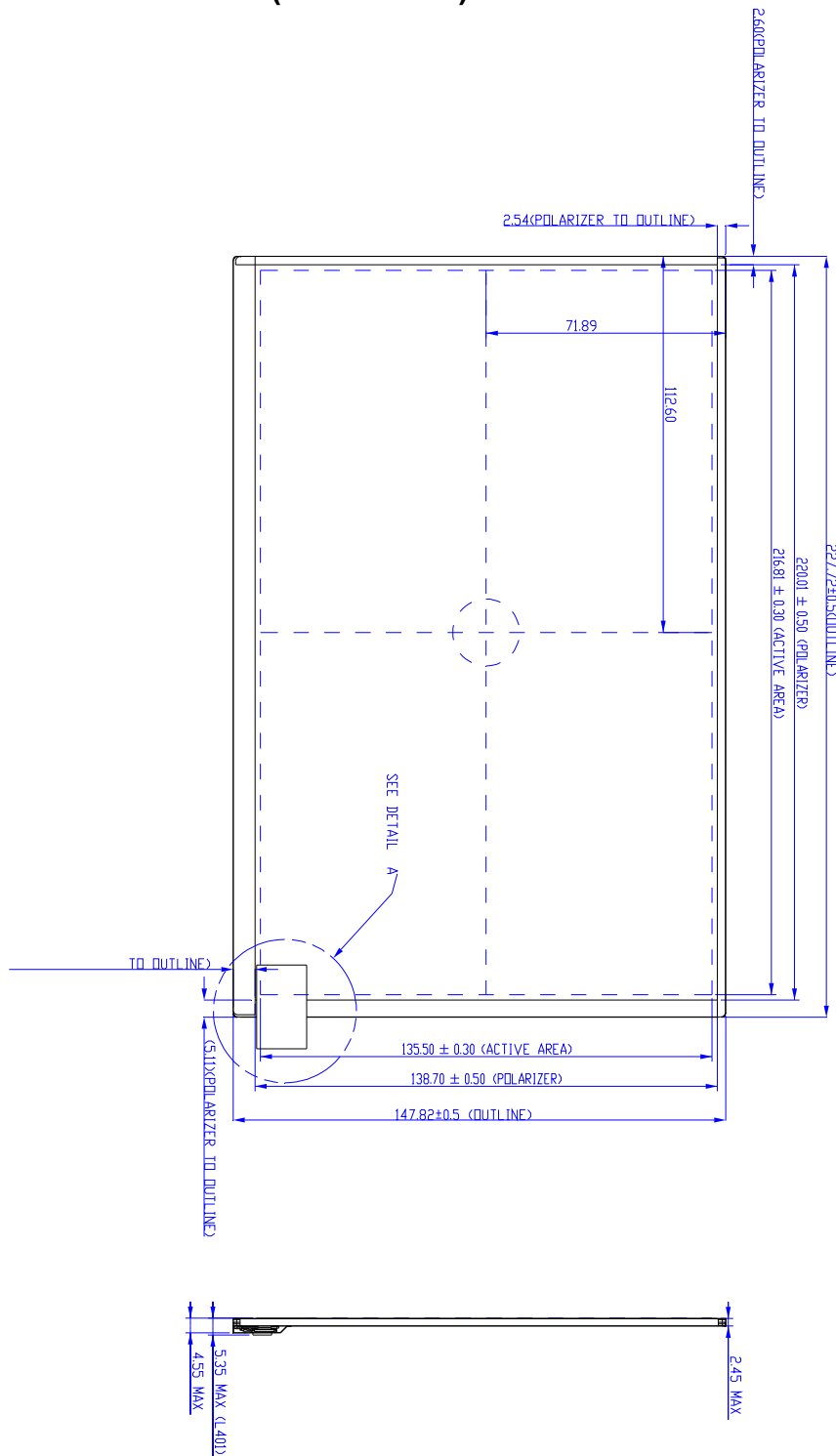



8.2 Outline Dimension (Rear View)

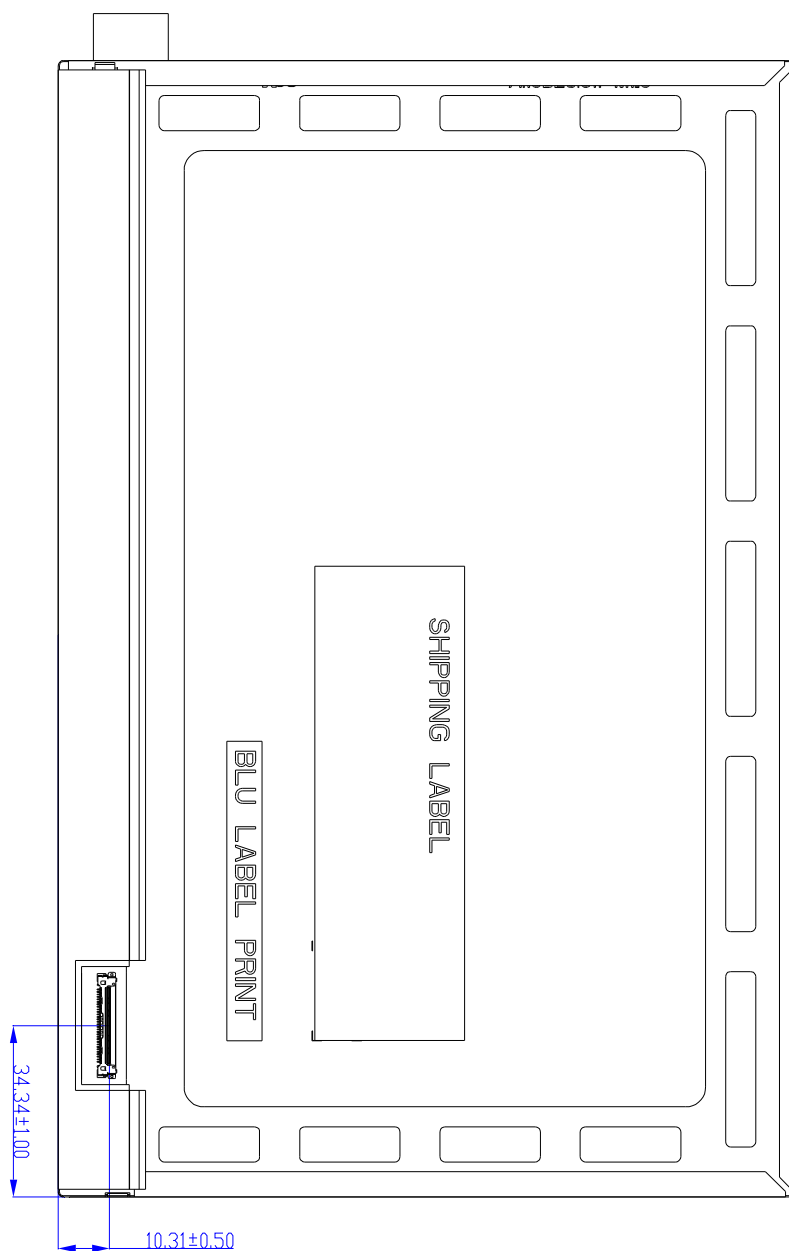



9. Label and Packaging

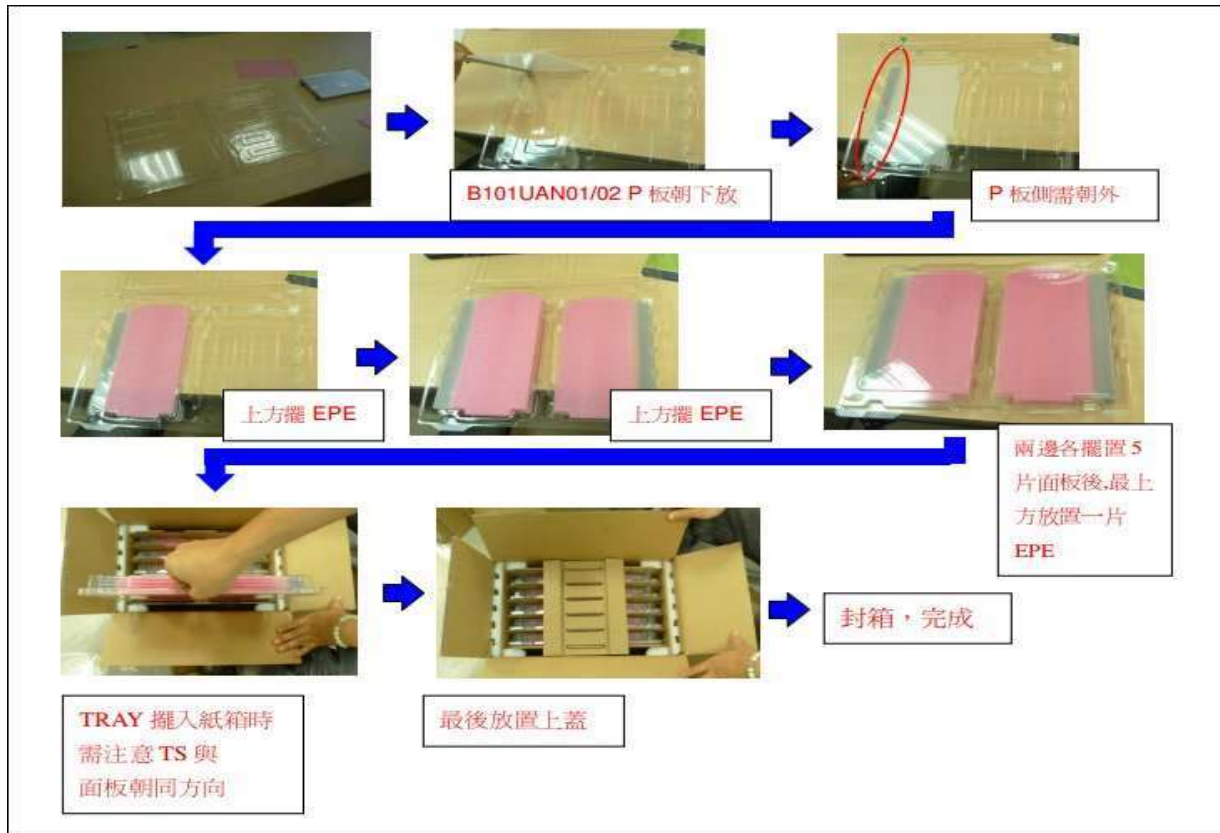

Max capacity

Outside dimension of carton: 445mm(H)*283mm(W)*377mm(H)

Pallet size : 1150 mm * 910 mm * 132mm

入庫堆棧層數: 3 层

Box stacked

Module by air : (4*2) *3layers , one pallet put 24 boxes , total 1250pcs module

Module by sea : (4 *2) *3layers+(4 *2) *2layers, two pallets put 40boxes , total 2000pcs module

Module by sea_HQ : (4*2) *3 layers+(4 *2) *3layers, two pallets put 48 boxes , total 2400pcs module



10 Safety

10.1 Sharp Edge Requirements

There will be no sharp edges or comers on the display assembly that could cause injury.

10.2 Materials

10.2.1 Toxicity

There will be no carcinogenic materials used anywhere in the display module. If toxic materials are used, they will be reviewed and approved by the responsible HG toxicologist.

10.2.2 Flammability

All components including electrical components that do not meet the flammability grade UL94-V1 in the module will complete the flammability rating exception approval process.

The printed circuit board will be made from material rated 94-V1 or better. The actual UL flammability rating will be printed on the printed circuit board.

10.3 Capacitors

If any polarized capacitors are used in the display assembly, provisions will be made to keep them from being inserted backwards.

10.4 National Test Lab Requirement

The display module will satisfy all requirements for compliance to:

UL 60950-1 second edition

U.S.A. Information Technology Equipment