



SPECIFICATION FOR TFT LCD MODULE

CUSTOMER : _____

CUSTOMER MODULE : _____

HG MODEL : HG101WU039

Preliminary Specification

Final Specification

Customer Confirmation column:

Approved by : _____ Dept. : _____ Data : _____

Please return one of the copies of the specification with your signature to us within two weeks after you receive this document. If it is not returned, we will assume that you agree to the entire contents of this specification document.

Designed by	Checked by	Approved by



1-4. Change List

	No.	Reason	Change Details		Remarks
			Before	After	

Remarks:



Contents

No.	Items	Page
1.0	General Description	5
2.0	Absolute Maximum ratings	9
3.0	Electrical specifications.	10
4.0	Signal Timing Specifications	14
5.0	Optical specifications.	22
6.0	Mechanical Outline Dimension	26
7.0	Reliability Test	33
8.0	Packing information	34
9.0	Handing & Cautions	36



1.0. GENERAL DESCRIPTION

Block Diagram

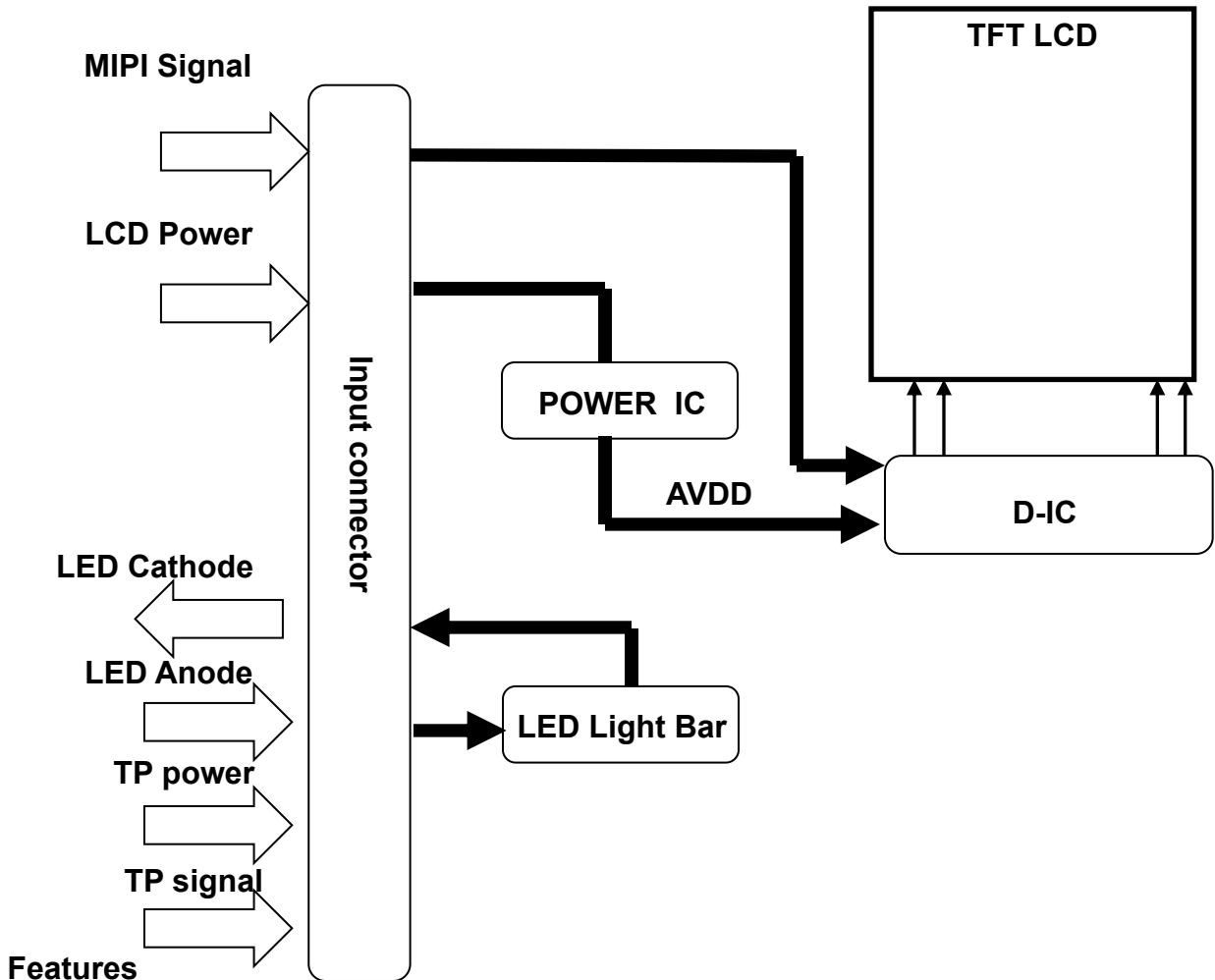

Features

1、HG101WU039 is 10.1" color TFT-LCD (Thin Film Transistor Liquid Crystal Display) module composed of LCD panel, Power Drive IC, MIPI driver ICs, control circuit and backlight. By applying 8 bit digital data, 1200×RGB (3) ×1920, 16.7M-color images are displayed on the 10.1" diagonal screen



1.1 General Specifications

Parameter	Specification	Unit	Remarks
Screen Size	10.1	Inch	
Active Area	135.36X216.576	mm	
Panel Size	140.26X220.346	mm	
Outline Dimension	142.8*228.2*4.5	mm	W/I BL bending area
Display Resolution	1200*RGB*1920	pixel	
Pixel Pitch	37.6*112.8	um	
Display Method	HADS	-	
Display Mode	Normal black	-	
Display Color	16.7M	-	
Color Gamut	70.8	%	NTSC
Luminance	300-350 (可定制高亮)	nit	Center
Contrast Ratio	Typ 1000:1	-	
Viewing Angle	80/80/85/85(CR>10)	-	Single Center Point
Pol Surface Treatment	HC+Clear	-	力特光电
Weight	/	g	
D-IC	HX8279-D*2	-	
Inversion Method	Column	-	
LED Q'ty	32	ea	
Power Consumption	max 2.92 (@white pattern)	mw	Logic+Backlight



1.3.1. PCBA Gerber/Layout and Schematic Diagram

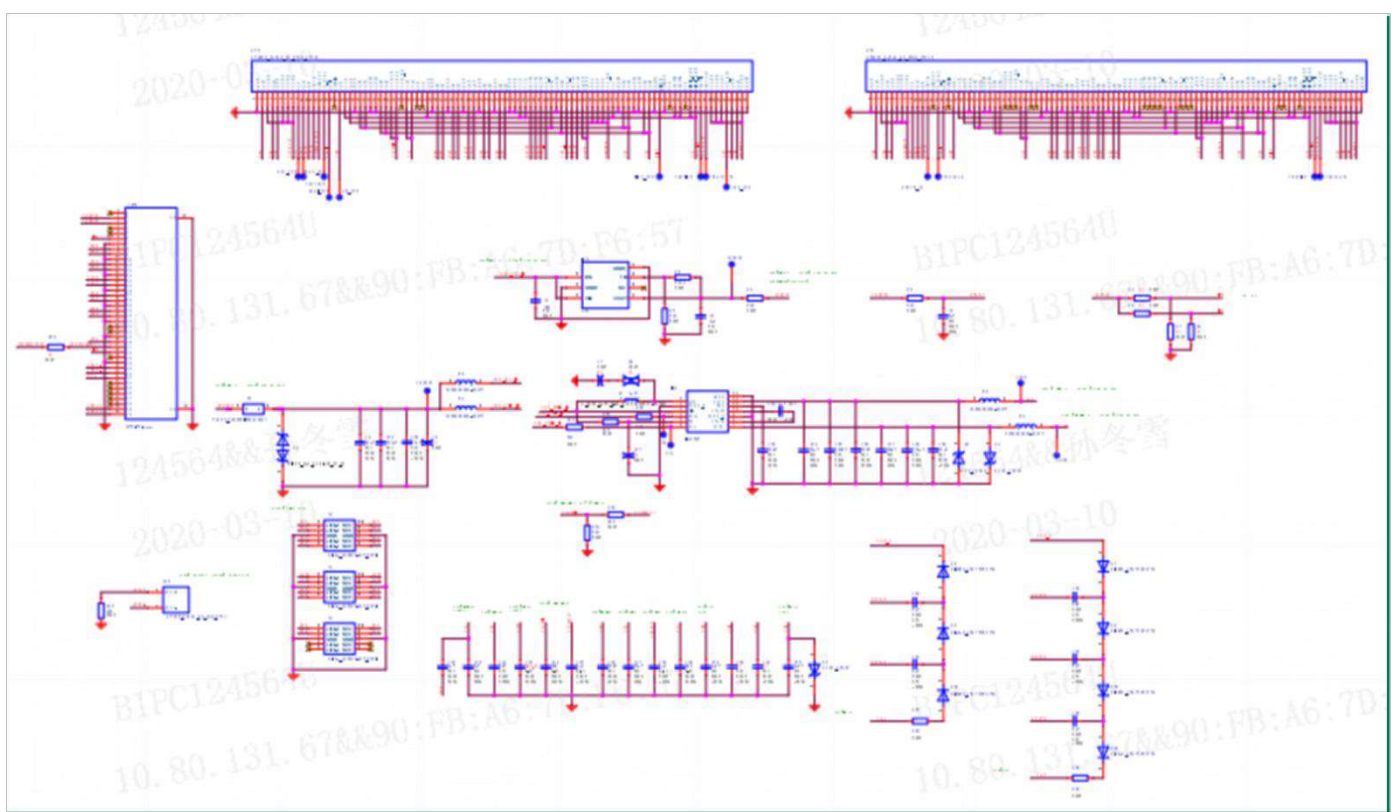
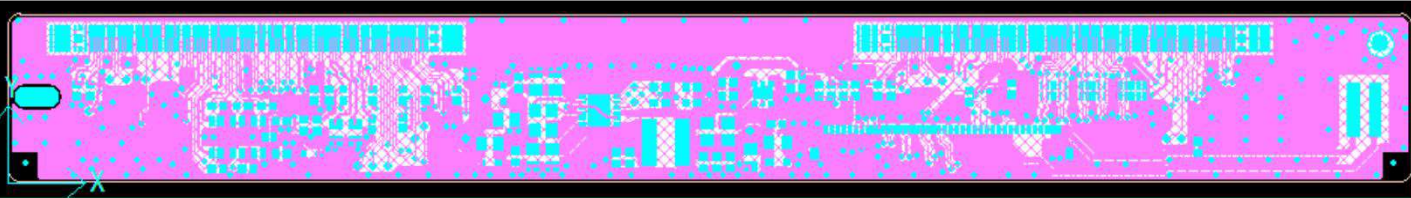



1.3.2. FPC Pin Assignment

Please pay attention that IC bump down(TFT glass up and C/F glass down)

PIN NO.	Symbol	PIN NO.	Symbol	PIN NO.	Symbol	PIN NO.	Symbol	PIN NO.	Symbol
No.1	GND	No.23	GND	No.45	D2P	No.67	NC(DRVL2)	No.89	UPDNB
No.2	NULL	No.24	AVDD	No.46	GND	No.68	NC(DRVL1)	No.90	CABC_ENB0
No.3	VGL	No.25	AVDD	No.47	CLKN	No.69	VLPH	No.91	CABC_ENB1
No.4	VCOM	No.26	AGND	No.48	CLKP	No.70	VLPH	No.92	CE_ENB
No.5	VGL	No.27	AGND	No.49	GND	No.71	VDD	No.93	OPDRV0
No.6	VGH	No.28	HAVDD	No.50	D1N	No.72	VDD	No.94	OPDRV1
No.7	VGH	No.29	HAVDD	No.51	D1P	No.73	VDD	No.95	LVDS/MIPI
No.8	VCOM	No.30	VCOMO	No.52	GND	No.74	VCC_EN	No.96	LVFMT
No.9	VCOM	No.31	VCOMO	No.53	D0N	No.75	VCC	No.97	TESTIN
No.10	VCOM	No.32	VCOMO	No.54	D0P	No.76	GND	No.98	TESTOUT
No.11	SCL	No.33	VCOM_EN	No.55	GND	No.77	AVDD	No.99	VCOM
No.12	SDA	No.34	HAOP	No.56	GND	No.78	AVDD	No.100	VCOM
No.13	GRB	No.35	HAOP	No.57	VCC	No.79	AVDD	No.101	VCOM
No.14	STBYB	No.36	HAOP	No.58	VCC	No.80	AGND	No.102	VPP_MTP
No.15	PWMOUT	No.37	VQH	No.59	NC(DRVH3)	No.81	AGND	No.103	VGH
No.16	TP_SYNC	No.38	VQL	No.60	NC(DRVH2)	No.82	AGND	No.104	VGH
No.17	XON	No.39	VCC	No.61	NC(DRVH1)	No.83	HAVDD	No.105	VGL
No.18	PWMIN	No.40	GND	No.62	NC(VSP_O)	No.84	HAVDD	No.106	VGL
No.19	CMD_SEL	No.41	D3N	No.63	NC(VSP)	No.85	HAVDD	No.107	Dummy
No.20	PORT2B	No.42	D3P	No.64	NC(AGND)	No.86	RTERM_EN	No.108	Dummy
No.21	VCC	No.43	GND	No.65	NC(VSN)	No.87	BISTB	No.109	NULL
No.22	VDD	No.44	D2N	No.66	NC(VSN_O)	No.88	SHLR	No.110	Dummy



2.0 ABSOLUTE MAXIMUM RATINGS

The followings are maximum values which, if exceed, may cause faulty operation or damage the unit. The operational and non-operational maximum voltage and current values are listed in the following table .

Parameter	Symbol	Min.	Typ.	Max.	Unit	Remarks
Logic Power Supply Voltage	V_{DD}	3.1	3.3	3.5	V	Note1
LED Forward Current of every LED string	I_{LED}	-	23	-	mA	Note2
LED string Reverse Voltage	V_R	-	-	26.4	V	
Operating Temperature	T_{OP}	-20	-	+60	°C	Note3
Storage Temperature	T_{ST}	-30	-	+70	°C	

- Notes : 1. Permanent damage to the device may occur if maximum values are exceeded functional operation should be restricted to the condition described under normal operating conditions.
2. the max value of LED forward current is relative to ambient temperature, the correlation is show in figure 1.
3. Temperature and relative humidity range are shown in the figure below.
95 % RH Max. ($40\text{ }^{\circ}\text{C} \geq T_a$)
Maximum wet - bulb temperature at 39 OC or less. ($T_a > 40\text{ OC}$) No condensation.

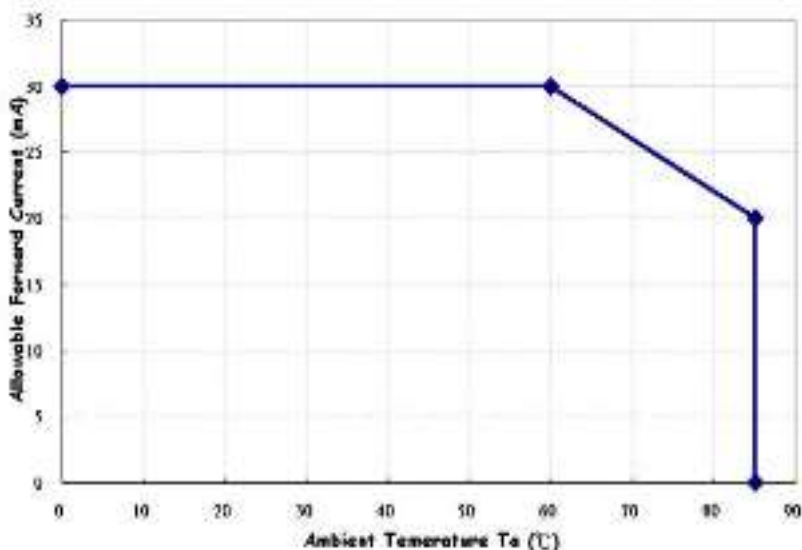

Figure 1. forward current vs ambient temperature

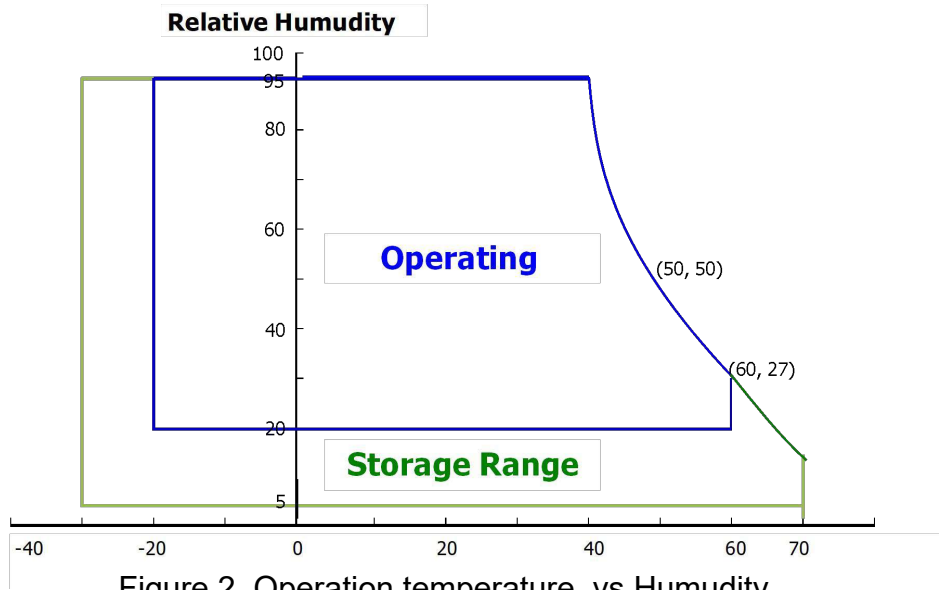

Figure 2. Operation temperature vs Humidity

3.0 Electrical Specifications

[Ta = 25±2 °C]

Parameter	Symbol	Values			Unit	Notes
		Min	Typ	Max		
Logic Power Supply Input Voltage	VDDI	3.1	3.3	3.5	Vdc	1
LED Forward Voltage of every LED string	V _{LED}	22.4	-	26.4	Vdc	
LED Forward Current of every LED string	I _{LED}	-	23	-	mA	@60°C
Logic Power Consumption	P _{logic}	-	-	0.56	W	@W
BLU Power Consumption	P _{blu}	-	2.3	2.43	W	23mA
Rush current	IRUSH	-	0.7	1.3	A	2

- Notes :
- The supply voltage is measured and specified at the interface connector of LCM.
The current draw and power consumption specified is for VDD=3.3V, Frame rate fV=60Hz.
Test pattern of power supply current is : Max. @White Pattern
 - The duration of rush current is about 2ms



3.1. Logic Power Consumption

Parameter	Symbol	Typ.		uite	Notes
		Typ.	Max.		
Normal Mode	IVDD	150	170	mA	@W



3.2 BACK LIGHT UNIT

The edge-lighting type of back light unit consists of 32 LEDs which is connected in serial.

Table 3.1 Electrical Characteristics Of Back Light Unit

Parameter	Symbol	Values			Units	Notes
		Min	Typ.	Max		
LED Current	I_{LED}	-	92	-	mA	
LED Forward Voltage	V_{LED}	22.4	-	26.4	V	

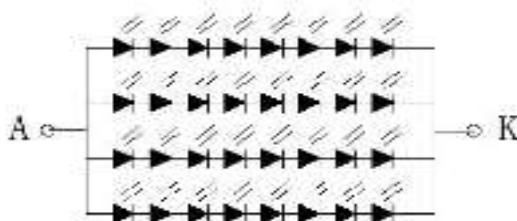

8*4-32LED 23*4-92mA

LED Circuit Diagram

3-2-1 LED Rank

Luminous Flux Rank Chart

Condition	Bin code	Luminous Flux rank* (Lm)		Luminous Intensity for reference (mcd)	
		Min.	Max.	Min.	Max.
IF = 20mA		8.5	9.0	3150	3350

Color Rank Chart



3.3. LCD INTERFACE CONNECTIONS

Interface Connector: FPC Connector **FH33J-40S-0.5SH** is used for the module electronics interface.

<Table 3.2. Pin Assignments for the Interface Connector>

10.1 inch WUXGA ADS Portrait									
Pin NO.	Symbol	Pin NO.	Symbol	Pin NO.	Symbol	Pin NO.	Symbol	Pin NO.	Symbol
1	NC	9	MIPI_OP	17	MIPI_2N	25	GND	33	SCL
2	VDD	10	GND	18	MIPI_2P	26	SDA	34	WPN
3	VDD	11	MIPI_1N	19	GND	27	PWMO	35	NC
4	NC	12	MIPI_1P	20	MIPI_3N	28	ID(1.8V)	36	MTP
5	NC	13	GND	21	MIPI_1P3	29	GND	37	NC
6	ID(0V)	14	MIPI_CKN	22	GND	30	GND	38	NC
7	GND	15	MIPI_CKP	23	NC	31	LED-	39	LED+
8	MIPI_ON	16	GND	24	NC	32	LED-	40	LED+

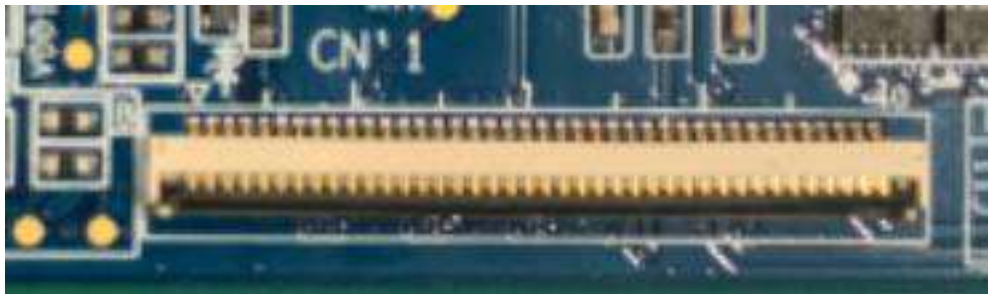

Pin1



4.0. SIGNAL TIMING SPECIFICATIONS

ITEM		SYMBOL	min	typ	max	UNIT	
LCD	Frame Rate	-	-	60	-	Hz	
	Pixels Rate	-	-	156	-	MHz	
Timing	Mipi CLK	Frequency	fCLK	-	468	-	MHz
		Period	Tclk	-	2.14	-	ns
	Horizontal	Horizontal total time	tHP	-	1340	2047	t _{CLK}
		Horizontal Active time	tHadr	1200			t _{CLK}
		Horizontal Pulse Width	tHsync	-	24	-	t _{CLK}
		Horizontal Back Porch	tHBP	-	80	-	t _{CLK}
		Horizontal Front Porch	tHFP	-	60	-	t _{CLK}
	Vertical	Vertical total time	tvp	-	1944	2047	t _H
		Vertical Active time	tVadr	1920			t _H
		Vertical Pulse Width	tVsync	-	2	-	t _H
		Vertical Back Porch	tVBP	-	10	-	t _H
		Vertical Front Porch	tVFP	-	14	-	t _H
Bit Rate		TX SPD (MBPS)	980	980	995	Mbps	
Lane			-	4	-	Lane	





4.1 MIPI interface (Mobile Industry Processing Interface)

The Display Serial Interface standard defines protocols between a host processor and peripheral devices that adhere to MIPI Alliance standards for mobile device interfaces. The DSI standard builds on existing standards by adopting pixel formats and command set defined in MIPI Alliance standards.

DSI-compliant peripherals support either of two basic modes of operation: Command Mode and Video Mode. Which mode is used depends on the architecture and capabilities of the peripheral. The mode definitions reflect the primary intended use of DSI for display interconnect, but are not intended to restrict DSI from operating in other applications.

Command Mode refers to operation in which transactions primarily take the form of sending commands and data to a peripheral, such as a display module, that incorporates a display controller. The display controller may include local registers. Systems using Command Mode write to, and read from the registers. The host processor indirectly controls activity at the peripheral by sending commands, parameters and data to the display controller. The host processor can also read display module status information. Command Mode operation requires a bidirectional interface.

Video Mode refers to operation in which transfers from the host processor to the peripheral take the form of a real-time pixel stream. In normal operation, the display module relies on the host processor to provide image data at sufficient bandwidth to avoid flicker or other visible artifacts in the displayed image. Video information should only be transmitted using High Speed Mode. To reduce complexity and cost, systems that only operate in Video Mode may use a unidirectional data path.



4.1.1 MIPI DC Specification

Parameter	Symbol	Min	Typ	Max	Unit	Condition
MIPI Characteristics for High Speed Receiver						
Differential input low voltage	V_{IDTL}	-70	-	-	mV	
Differential input high voltage	V_{IDTH}	-	-	70	mV	
Single-ended input low voltage	V_{ILHS}	-40	-	-	mV	
Single-ended input high voltage	V_{IHHS}	-	-	460	mV	
Common-mode voltage	V_{CMRXDC}	70	-	330	mV	
Differential input impedance	Z_{ID}	80	100	125	Ω	
HS transmit differential voltage ($V_{OD}=V_{DP}-V_{DN}$)	$ V_{OD} $	140	200	270	mV	
MIPI Characteristics for Low Power Receiver						
Input low level	V_{IH}	880	-	-	mV	
Input high level	V_{IL}	0	-	550	mV	
Output low level	V_{OL}	-50	-	50	mV	
Output high level	V_{OH}	1.1	1.2	1.3	V	

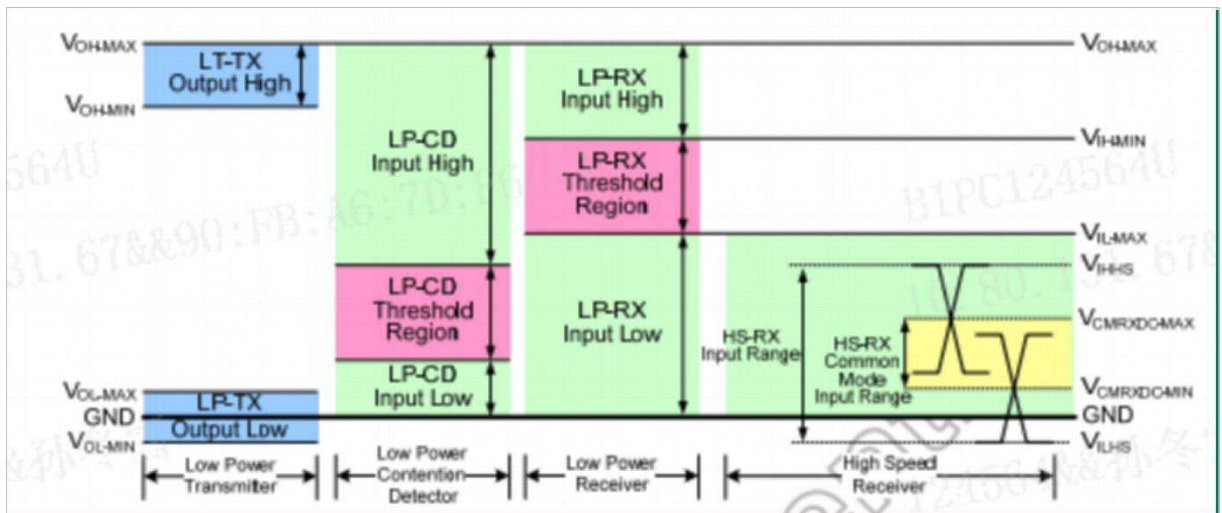



4.1.2 MIPI AC Specification

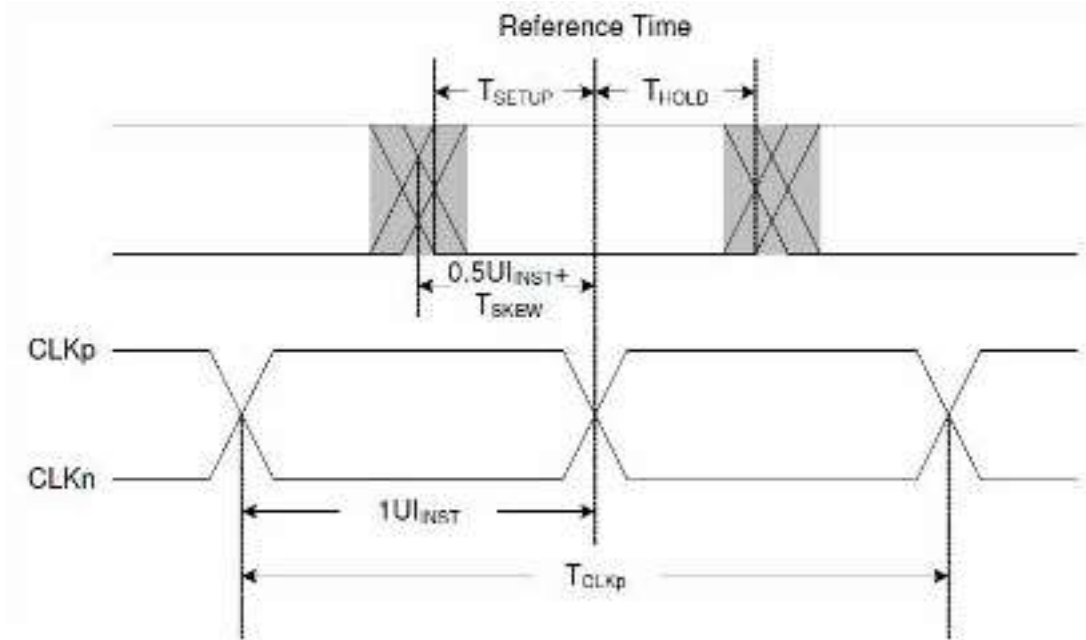

Description	Symbol	Condition	Min	Typ	Max	Unit
UI instantaneous	UIINST	-	1.0	-	12.5(1)	ns
Data to Clock Setup Time	TSETUP	-	0.3	-	-	UIINST
Clock to Data Hold Time	THOLD	-	0.3	-	-	UIINST

Note: (1) This value corresponds to a minimum 80 Mbps data rate.



4.3. IC General Spec and Size

- MIPI interface support 2/4 lanes
- Support Multi-Drop and R/L type MIPI interface
- Two chip cascade solution for high resolution TFT LCD driver
- 1803 channel output, build in source driver and TCON
 - Channel number 1803 is for zigzag panel(M+1 and M+3) only
- Resolution:
 - Two chip solution for 1200RGBx1920, 1080RGBx1920, and 1200RGBx1600
 - One chip solution for 600RGB x 1024
- Support gamma curve adjustment by analog gamma and the RGB-separated positive/negative digital gamma (It can set thru MIPI command)
- 256 gray scale driving output compliant to 8bit display data
- Driving scheme support 1/2/1+2/4 dot, and column inversion.
- Support CABC function
- Support Color enhancement function
- Support external gate driver controlled signals and GOA function
- Support BIST mode
- Support stripe and zigzag panel
- Support VGH & VGL external charge pump controlled signals
- Support 8 times OTP for VCOM and 1 time OTP for gamma programming
- Only request three powers(VDD,VSP,VSN) from HOST
- Digital power range VDD:1.7V~2.0V
- Analog power range VSP:4.5V~6.0V VSN:-4.5V~-6.0V
- Output bump pitch is 12 μ m
- COG package

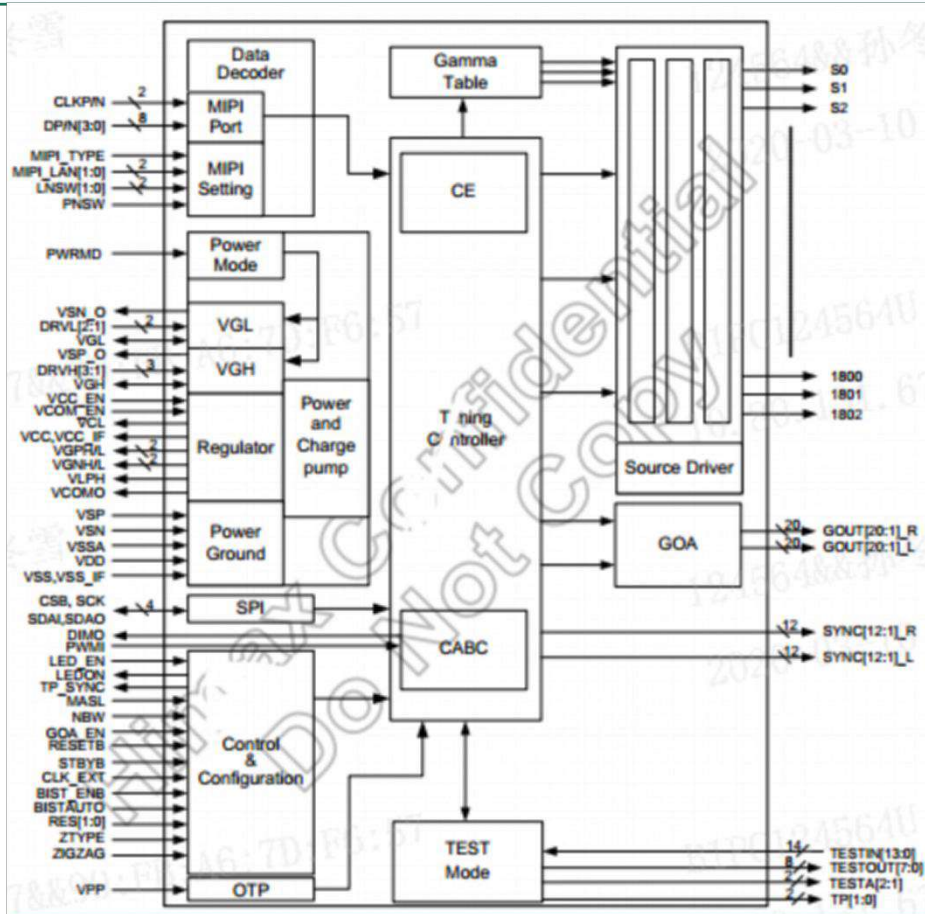



4.4. Power Consumption

	Parameter	Symbol	Typ.	Unit	Remark
CABC OFF	Logic Power	L255	562.3	mW	
	BLU	100% on	2.28	W	

If there is more than one mode for CABC function please fill out all data



4.5. Initial Code

RB0 05	RB0 02	RB0 06	RB0 08	RB0 09	RB0 0B	RB0 0C
RB1 E5	RC0 00	RB8 A5	RB1 04	RB1 04	RB1 04	RB1 04
RB3 52	RC1 0F	RC0 A5	RB2 04	RB2 04	RB2 04	RB2 04
RC0 05	RC2 1A	RC7 0F	RB3 10	RB3 0D	RB3 10	RB3 0D
RD9 85	RC3 2B	RD5 32	RB4 23	RB4 22	RB4 23	RB4 22
RC2 55	RC4 38	RB8 00	RB5 37	RB5 37	RB5 37	RB5 37
	RC5 39	RC0 00	RB6 4B	RB6 4C	RB6 4B	RB6 4C
RB0 00	RC6 38	RBC 00	RB7 6D	RB7 6E	RB7 6D	RB7 6E
RB3 88	RC7 38		RB8 9C	RB8 9D	RB8 9C	RB8 9D
RB6 0B	RC8 36	RB0 07	RB9 D8	RB9 DA	RB9 D8	RB9 DA
RBA 8B	RC9 34	RB1 08	RBA 17	RBA 19	RBA 17	RBA 19
RBF 1A	RCA 35	RB2 09	RBB 93	RBB 9A	RBB 93	RBB 9A
RC0 0F	RCB 36	RB3 13	RBC 1C	delay 5	RBC 1C	RBC 25
RC2 0C	RCC 39	RB4 23	RBD 20	RBC 25	RBD 20	RBD 29
RC3 02	RCD 2D	RB5 37	RBE 9D	RBD 29	RBE 9D	RBE A7
RC4 0C	RCE 2D	RB6 4B	RBF 1C	RBE A7	RBF 1C	RBF 26
RC5 02	RCF 2C	RB7 6D	RC0 5B	RBF 26	RC0 5B	RC0 63
	RD0 07	RB8 9C	RC1 96	RC0 63	RC1 96	RC1 9C
RB0 01	RD2 00	RB9 D8	RC2 B1	RC1 9C	RC2 B1	RC2 B6
RE0 26	RD3 0F	RBA 17	RC3 CD	RC2 B6	RC3 CD	RC3 D1
RE1 26	RD4 1A	RBB 93	RC4 DA	RC3 D1	RC4 DA	RC4 DC
RDC 00	RD5 2B	RBC 1B	RC5 E7	RC4 DC	RC5 E7	RC5 E9
RDD 00	RD6 38	RBD 1F	RC6 F4	RC5 E9	RC6 F4	RC6 F5
RCC 26	RD7 39	RBE 9B	RC7 FA	RC6 F5	RC7 FA	RC7 FA
RCD 26	RD8 38	RBF 19	RC8 FC	RC7 FA	RC8 FC	RC8 FC
RC8 00	RD9 38	RC0 57	RC9 00	RC8 FC	RC9 00	RC9 00
RC9 00	RDA 36	RC1 93	RCA 00	RC9 00	RCA 00	RCA 00
RD2 03	RDB 34	RC2 AE	RCB 16	RCA 00	RCB 16	RCB 16
RD3 03	RDC 35	RC3 CA	RCC AF	RCB 16	RCC AF	RCC AF
RE6 04	RDD 36	RC4 D7	RCD FF	RCC AF	RCD FF	RCD FF
RE7 04	RDE 39	RC5 E5	RCE FF	RCD FF	RCE FF	RCE FF
RC4 09	RDF 2D	RC6 F3		RCE FF		
RC5 09	RE0 2D	RC7 F9				RB0 00
RD8 0A	RE1 2C	RC8 FC				RB3 08
RD9 0A	RE2 07	RC9 00				
RC2 0B		RCA 00				RB0 04
RC3 0B	RB0 03	RCB 16				RB5 02
RD6 0C	RC8 0B	RCC AF				RB6 01
RD7 0C	RC9 07	RCD FF				RB8 FF
RC0 05	RC3 00	RCE FF				
RC1 05	RE7 00					
RD4 06	RC5 2A					
RD5 06	RDE 2A					
RCA 07	RCA 43					
RCB 07	RC9 07					
RDE 08	RE4 C0					
RDF 08	RE5 0D					
	RCB 00					



5.0 Optical Specifications -Backlight 100%

The test of Optical specifications shall be measured in a dark room (ambient luminance ≤ 1 lux and temperature = $25 \pm 2^\circ\text{C}$) with the equipment of Luminance meter system (CA-310、BM-5A) and test unit shall be located at an approximate distance 50cm from the LCD surface at a viewing angle of θ and Φ equal to 0° .

Parameter		Symbol	Condition	Min.	Typ.	Max.	Unit	Remark
Viewing Angle range	Horizontal	Θ_3	CR > 10		85	-	Deg.	Note 1
		Θ_9			85	-	Deg.	
	Vertical	Θ_{12}			85	-	Deg.	
		Θ_6			85	-	Deg.	
Color Gamut				65	70.8	-	%	-
Luminance Contrast ratio		CR	$\Theta = 0^\circ$		1000 : 1		-	Note 2
Luminance of White	5 Points	Y_w	$\Theta = 0^\circ$	300	350	-	cd/m ²	Note 3 (LCM)
White Luminance uniformity	13 Points	ΔY_{13}		70	75	-	%	Note 4
	5 Points	ΔY_5		80	85	-	%	
White balance		W_x	$\Theta = 0^\circ$	0.27	0.30	0.33	-	Note 5
		W_y		0.28	0.31	0.34	-	
		CT		/	6700	/	K	
Reproduction of color	Red	R_x	$\Theta = 0^\circ$	0.67	0.64	0.61	-	Note6 (TLCM)
		R_y		0.30	0.33	0.36		
	Green	G_x		0.27	0.30	0.33		
		G_y		0.57	0.60	0.63		
	Blue	B_x		0.12	0.15	0.18		
		B_y		0.028	0.058	0.088		
Response Time (Rising + Falling)		T_{RT}	Ta= 25° C $\Theta = 0^\circ$	25	30	35	ms	Note 7

Cell & BLU Optical Characteristics

Parameter	Typ	Unit	Remarks
Aperture Ratio	70	%	
Upper Pol Trans.	-	%	
Lower Pol Trans.	-	%	
Panel Trans.	-	3.7% (参考小米向BLU)	w/o APF
BLU Luminance	7700	Cd/m ²	5 Points



Note :

1. Viewing angle is the angle at which the contrast ratio is greater than 10. The viewing angles are determined for the horizontal or 3, 9 o'clock direction and the vertical or 6, 12 o'clock direction with respect to the optical axis which is normal to the LCD surface (see FIGURE 1).
2. Contrast measurements shall be made at viewing angle of $\Theta = 0$ and at the center of the LCD surface. Luminance shall be measured with all pixels in the view field set first to white, then to the dark (black) state. (see FIGURE 1) Luminance Contrast Ratio (CR) is defined mathematically.

$$CR = \frac{\text{Luminance when displaying a white raster}}{\text{Luminance when displaying a black raster}}$$

3. Center Luminance of white is defined as luminance values of 1point average across the LCD surface. Luminance shall be measured with all pixels in the view field set first to white. This measurement shall be taken at the locations shown in FIGURE 1 for a total of the measurements per display. The luminance is measured by CA310 when the LED current is set at 20mA.
4. The White luminance uniformity on LCD surface is then expressed as : $\Delta Y = \text{Minimum Luminance of 9points} / \text{Maximum Luminance of 9points}$ (see FIGURE 2).
5. The color chromaticity coordinates specified shall be calculated from the spectral data measured with all pixels first in red, green, blue and white. Measurements shall be made at the center of the panel.
6. The color chromaticity coordinates specified shall be calculated from the spectral data measured with all pixels first in red, green, blue and white. Measurements shall be made at the center of the panel.
7. The electro-optical response time measurements shall be made as FIGURE 3 by switching the "data" input signal ON and OFF. The times needed for the luminance to change from 10% to 90% is T_r , and 90% to 10% is T_d .



Figure 1. Measurement Set Up

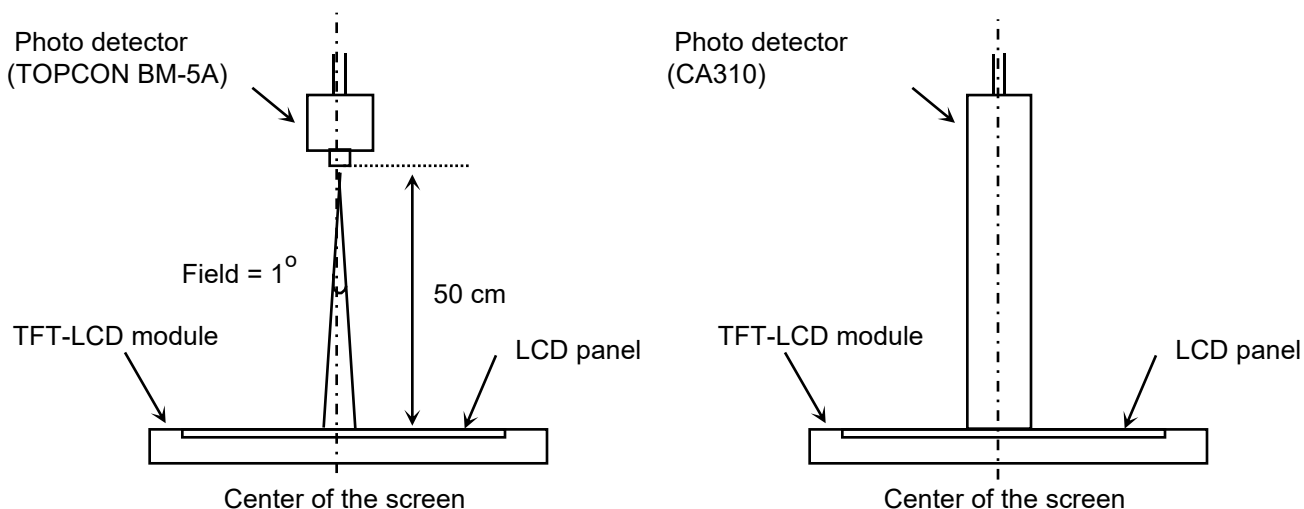

View angle range measurement setup Luminance , uniformity and color measurement setup

Figure 2. White Luminance and Uniformity Measurement Locations (13 points)

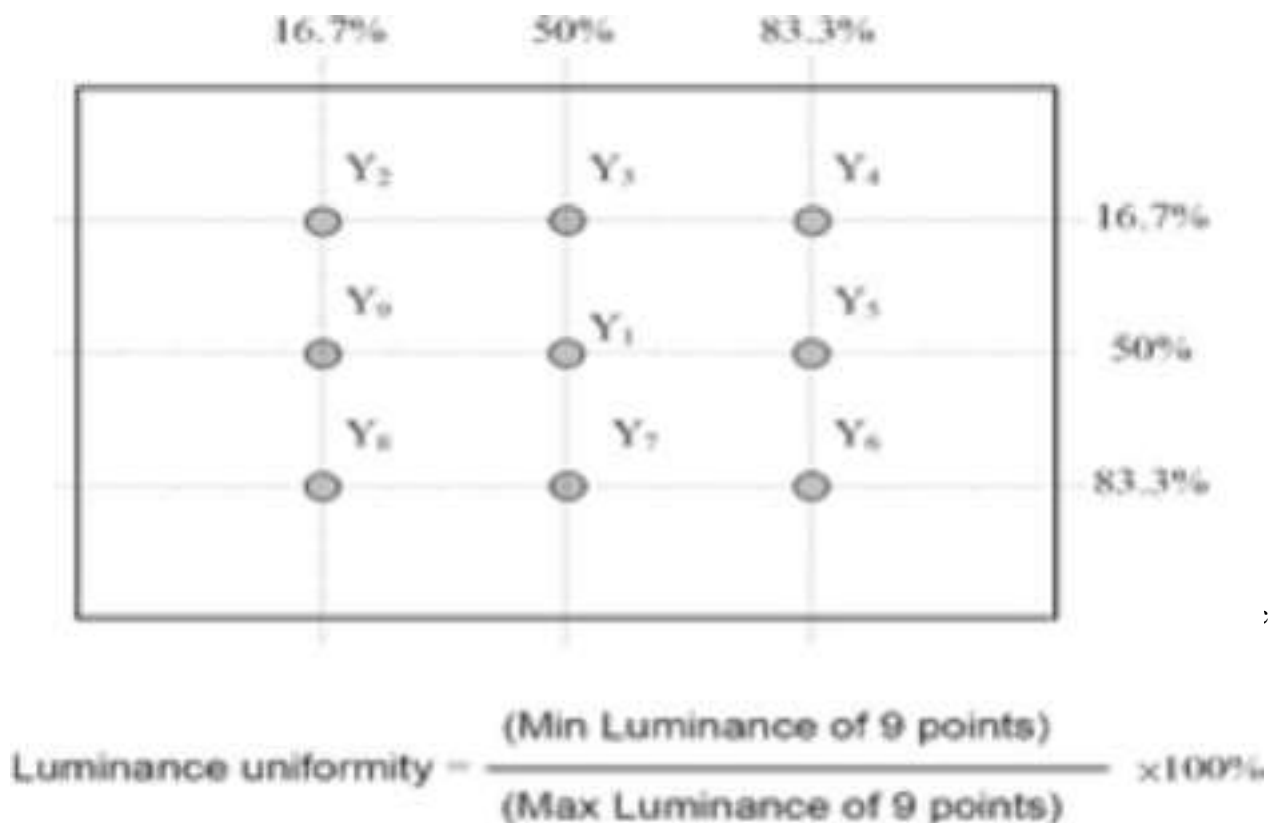
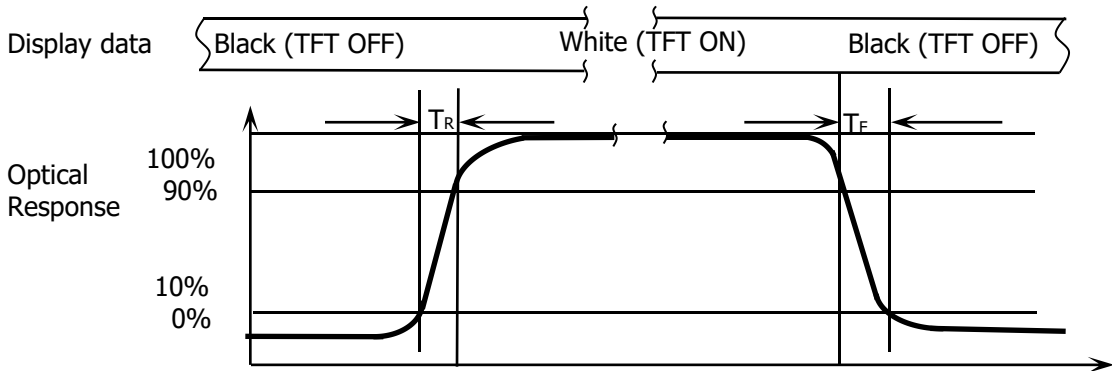



Figure 3. Response Time Testing



The electro-optical response time measurements shall be made as shown in FIGURE 3 by switching the “data” input signal ON and OFF. The times needed for the luminance to change from 10% to 90% is T_r and 90% to 10% is T_d .



6. MECHANICAL CHARACTERISTICS

The contents provide general mechanical characteristics for the model.

In addition the figures in the next page are detailed mechanical drawing of the LCD.

item	Description	Typ.	Tolerance	Unit	
Mother glass	Size	2500*2200	-	mm	
CF and TFT thickness after s limming	thickness	0.2/ 0.2		mm	
Panel	AA	A/A	216.576*135.36	-	mm
	CF	CF	222.046*140.26	±0.2	mm
	TFT	TFT	225.346*140.26	±0.2	mm
	BM	BM(U/D/L/R)	2.0/6.77/2.45/2.45	-	mm
	IC Bonding ar ea	IC Bonding Ar ea	19.5	-	mm
	Pol size	Pol Size	CF : 138.36*219.28 ; TFT : 139.86*219.48	±0.15	mm
	Gap between pol~glass(U/D /L/R)	Gap Between Pol~glassbord er (U/D/L/R)	CF: 0.8/1.97/0.95/0.95 TFT : 0.3/5.57/0.3/0.3	±0.3	mm
Module	Horizontal	Horizontal	142.76	±0.2	mm
	Vertical	Vertical	228.18	±0.2	mm
	Thickness	Thickness	2.15	±0.15	mm
	Uv glue thic kness	UV Glue Thic kness	no higher than IC	-	mm



7.0 Reliability Test

No	Test Item	Test Condition	Remark
1	High temperature storage test	Ta = 60 °C, 240 hrs	-
2	Low temperature storage test	Ta = -25°C, 240 hrs	
3	Thermal Shock Test	-10°C/1hr → 60°C/1hr × 10Cycle	
4	High temperature Operate test	Ta = 50 °C, 240hrs,	
5	Low temperature Operate test	Ta = 0 °C, 240hrs	
6	High temperature High humidity	Ta = 40 °C, 90% , 240hrs	

Note (1) criteria : Normal display image with no obvious non-uniformity and no line defect.

Note (2) Evaluation should be tested after storage at room temperature for more than two hour



8.0 Handling & Cautions

(1) Cautions when taking out the module

- Pick the pouch only, when taking out module from a shipping package.

(2) Cautions for handling the module

- As the electrostatic discharges may break the LCD module, handle the LCD module with care. Peel a protection sheet off from the LCD panel surface as slowly as possible.
- As the LCD panel and back - light element are made from fragile glass material, impulse and pressure to the LCD module should be avoided.
- As the surface of the polarizer is very soft and easily scratched, use a soft dry cloth without chemicals for cleaning.
- Do not pull the interface connector in or out while the LCD module is operating.
- Put the module display side down on a flat horizontal plane.
- Handle connectors and cables with care.

(3) Cautions for the operation

- When the module is operating, do not lose CLK, ENAB signals. If any one of these signals is lost, the LCD panel would be damaged.
- Obey the supply voltage sequence. If wrong sequence is applied, the module would be damaged.

(4) Cautions for the atmosphere

- Dew drop atmosphere should be avoided.
- Do not store and/or operate the LCD module in a high temperature and/or humidity atmosphere. Storage in an electro-conductive polymer packing pouch and under relatively low temperature atmosphere is recommended.

(5) Cautions for the module characteristics

- Do not apply fixed pattern data signal to the LCD module at product aging.
- Applying fixed pattern for a long time may cause image sticking.

(6) Other cautions

- Do not disassemble and/or re-assemble LCD module.
- Do not re-adjust variable resistor or switch etc.
- When returning the module for repair or etc., Please pack the module not to be broken. We recommend to use the original shipping packages.



深圳市鸿光显示有限公司

由 Autodesk 教育版产品制作

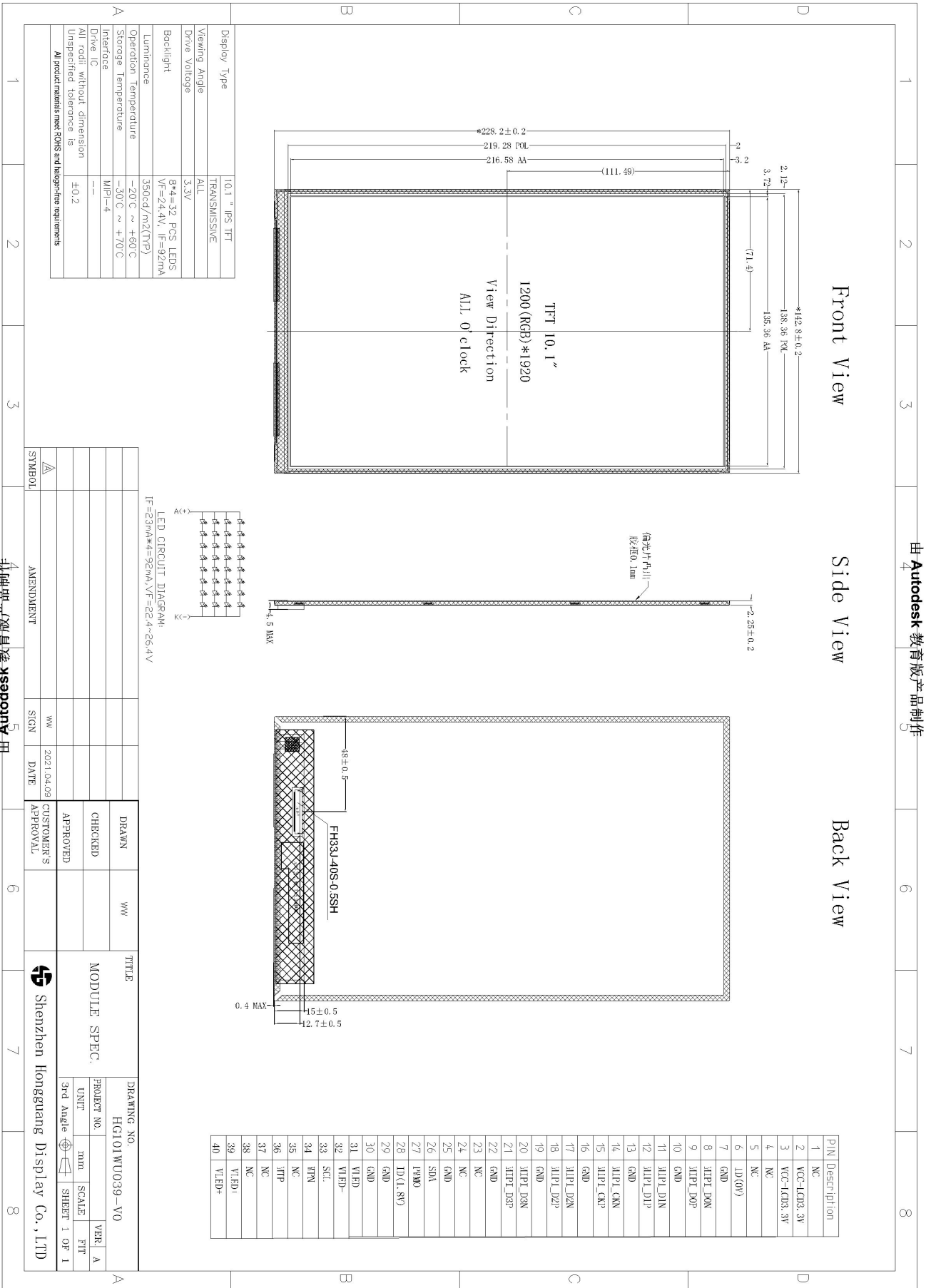

由 Autodesk 教育版产品制作

由 Autodesk 教育版产品制作

由 Autodesk 教育版产品制作

