



SPECIFICATION FOR TFT LCD MODULE

CUSTOMER : _____

CUSTOMER MODULE : _____

HL MODEL : HG101WU063



■Final Specification

Customer Confirmation column:

_____ Dept. : _____ Data : _____

Please return one of the copies of the specification with your signature to us within two weeks after you receive this document. If it is not returned, we will assume that you agree to the entire contents of this specification document.

Designed by	Checked by	Approved by



Contents

No.	Items	Page
1.0	General Description	4
2.0	Absolute Maximum Ratings	6
3.0	Electrical Specifications	7
4.0	Optical Specifications	13
5.0	Reliability Test	16
6.0	Packing Information	17
7.0	Handling & Cautions	19
8.0	Appendix	20



1.0 GENERAL DESCRIPTION

1.1 Introduction

HG101WU063 is a color active matrix TFT LCM using amorphous silicon TFT's (Thin Film Transistors) as an active switching devices. This module has a 10.1 inch diagonally measured active area with WUXGA resolutions (1920 horizontal by 1200 vertical pixel array). Each pixel is divided into RED, GREEN, BLUE dots which are arranged in vertical stripe and this module can display 16.7M colors.

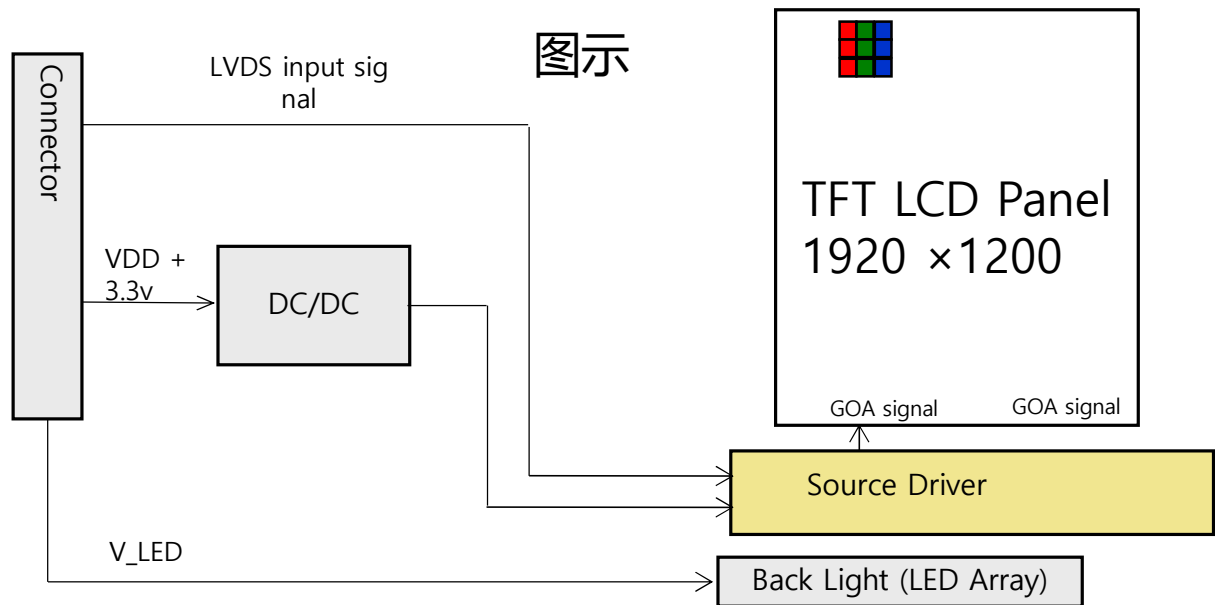

1.2 Features

- LVDS Interface;
- 8bit display 16.7M colors
- High contrast ratio and Transmittance



1.3 Application

- G Industrial

1.4 General Specification

The followings are general specifications at the HG101WU063

<Table 1. LCD Module Specifications>

Parameter	Specification	Unit	Remarks
Active Area	216.8064(H)*135.504(V)	mm	
Number Of Pixels	1920(H)×1200(V)	pixels	
Pixel Pitch	0.03764(H)×RGB×0.11292(V)	mm	
Pixel Arrangement	Pixels RGB stripe arrangement		
Display Mode	Normally Black		
Display Colors	16.7M(8bit)	colors	
Transmittance	3.85(Typ.)	%	
Surface Treatment	HC		
Contrast Ratio	900:1(typ.)		
Viewing Angle(CR> 10)	80/80/80/80(typ.)		
Response Time	30(typ.)/35(max.)	ms	
Color Gamut	72%NTSC		@BOE BLU
Power Consumption	Panel: 0.6(Typ.)	watt	@white
Outline Dimension	229.46(H)*149.1.(V)*4.8(typ)	mm	



2.0 ABSOLUTE MAXIMUM RATINGS

The followings are maximum values which, if exceed, may cause faulty operation or damage to the unit.

< Table 2. Absolute Maximum Ratings >

Parameter		Symbol	Min.	Max.	Unit	Remarks
Power Supply	LCD Module	VDD	VSS-0.3	3.6	V	Ta = 25 °C
Operating Temperature		T _{OP}	-20	+70	°C	
Storage Temperature		T _{ST}	-30	+80	°C	
Operating Ambient Humidity		H _{OP}	10	90	%RH	
Storage Humidity		H _{ST}	10	90	%RH	



3.0 ELECTRICAL SPECIFICATIONS

3.1 TFT LCD Module

< Table 3. LCD Module Electrical specifications > [Ta =25±2 °C]

Parameter	Symbol	Values			Unit	Notes	
		Min.	Typ.	Max.			
Power Supply Voltage	VDD	3.0	3.3	3.6	V		
	VRP			300	mV	Ripple	
Power Supply Current	IDD	-	300	360	mA	Note 1	
Power Consumption	PLCD	-	1	1.2	W		
Rush current	IRUSH	-	-	3.0	A	Note 2	
CMOS Interface	Input Voltage	VIH	2.7		3.3	V	
		VIL	0		0.5	V	
	Output Voltage	VOH	2.7		3.3	V	
		VOL	0		0.5	V	

Notes : 1. The supply voltage is measured and specified at the interface connector of LCM.
 The current draw and power consumption specified is for VDD=3.3V, Frame rate $f_v=60\text{Hz}$ and Clock frequency = 80MHz. Test Pattern of power supply current
 a) Typ : Mosaic 8 x 6 Pattern(L0/L255) b) Max : skip subPixel(L255)

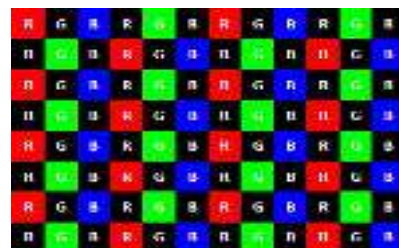
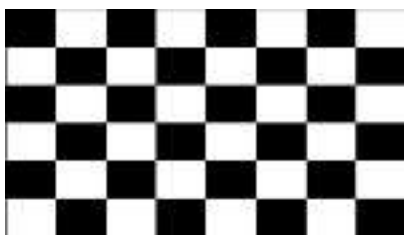

2. The duration of rush current is about 2ms and rising time of Power Input is 1ms(min)



3.2 INPUT TERMINAL PIN ASSIGNMENT

This LCD employs one interface connections, a 45 pin connector is used for the LCD module electronics interface.

3.2.1 Pin assignment for LCD module

Connector : FH34SRJ-45S-0.5SH(50) (HRS) or equivalent

< Table4. Pin Assignment for LCD Module Connector >

Pin No.	Symbol	Description	I/O
1	VLED-	LED Cathode	P
2	VLED-	LED Cathode	P
3	VLED+	LED Anode	P
4	VLED+	LED Anode	P
5	NC	NC	-
6	GND	GROUND	P
7	ELV3P	EVEN LVDS Positive data signal (+)	I
8	ELV3N	EVEN LVDS Negative data signal (-)	I
9	GND	GROUND	P
10	ELV2P	EVEN LVDS Positive data signal (+)	I
11	ELV2N	EVEN LVDS Negative data signal (-)	I
12	GND	GROUND	P
13	ELVCLKP	EVEN LVDS Positive CLK signal (+)	I
14	ELVCLKN	EVEN LVDS Negative CLK signal (-)	I
15	GND	GROUND	P
16	ELV1P	EVEN LVDS Positive data signal (+)	I
17	ELV1N	EVEN LVDS Negative data signal (-)	I
18	GND	GROUND	P
19	ELV0P	EVEN LVDS Positive data signal (+)	I
20	ELV0N	EVEN LVDS Negative data signal (-)	I



Pin No.	Symbol	Description	I/O
21	GND	GROUND	P
22	OLV3P	Odd LVDS Positive data signal (+)	I
23	OLV3N	Odd LVDS Negative data signal (-)	I
24	GND	GROUND	P
25	OLV2P	Odd LVDS Positive data signal (+)	I
26	OLV2N	Odd LVDS Negative data signal (-)	I
27	GND	GROUND	P
28	OLVCLKP	Odd LVDS Positive CLK signal (+)	I
29	OLVCLKN	Odd LVDS Negative CLK signal (-)	I
30	GND	GROUND	P
31	OLV1P	Odd LVDS Positive data signal (+)	I
32	OLV1N	Odd LVDS Negative data signal (-)	I
33	GND	GROUND	P
34	OLV0P	Odd LVDS Positive data signal (+)	I
35	OLV0N	Odd LVDS Negative data signal (-)	I
36	GND	GROUND	P
37	I2C_SDA	Reserved for LCD manufacturer' s use , not connection	I
38	I2C_SCL		I
39	VDD_OTP		P
40	EEPEN	Not Connection	I
41	VDDIN	Power supply VDDIN=3.3V (Typ.)	P
42	VDDIN		P
43	VDDIN		P
44	VDDIN		P
45	VDDIN		P



3.3 Interface timing Parameter and AC/DC Parameter

The QV101WUB-N80 is operated by the DE only

< Table5. LVDS Timing Parameter >

Parameter	Symbol	Value			Unit
		Min.	Typ.	Max.	
DCLK Frequency	Fdclk	74.5	77.56	85	MHz
Horizontal display area	Thd	960			DCLK
HSYNC period time	Th	989	1040	1248	DCLK
Horizontal Blank	THB	29	80	288	DCLK
HSYNC pulse width	Thp	2	10	255	DCLK
HSYNC back porch	thbp	3	6	255	DCLK
HSYNC Front porch	thfp	24	64	260	DCLK
Vertical display area	Tvd	1200			H
VSYNC period time	Tv	1243	1243	1560	H
Vertical Blank	TVB	43	43	360	H
VSYNC Pluse width	Tvp	4	4	20	H
VSYNC back porch	Tvbp	20	20	255	H
VSYNC front porch	Tvfp	19	19	260	H
Frequency	fV	-	60	-	Hz

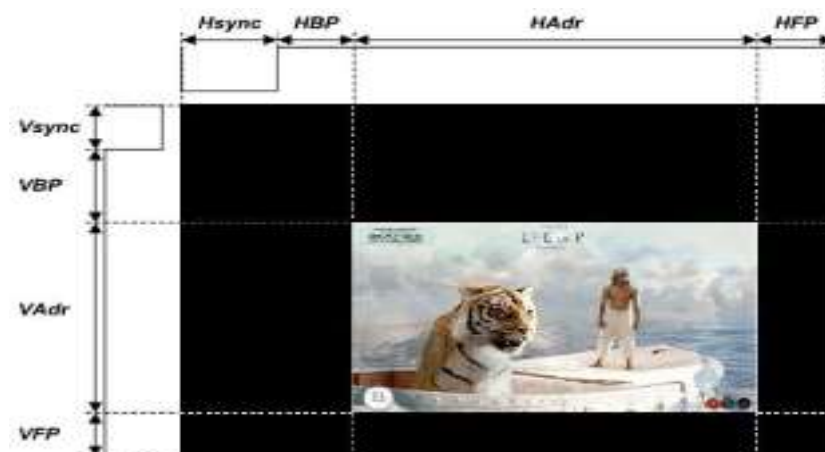



<Table 6. LVDS AC Timing Specification>

Item	Symbol	Min	Typ	Max	Unit	Remark
CLKfrequency	Frcip	20	-	85	MHZ	
CLKIN Period	tRCIP	11.76	-	-	nsec	
Input Data 0	tRIP1	$tRCIP/7 \times (-0.2)$	0.0	$tRCIP/7 \times 0.2$	nsec	
Input Data 1	tRIP0	$tRCIP/7 \times 0.8$	$tRCIP/7$	$tRCIP/7 \times 1.2$	nsec	
Input Data 2	tRIP6	$tRCIP/7 \times 1.8$	$tRCIP/7 \times 2$	$tRCIP/7 \times 2.2$	nsec	
Input Data 3	tRIP5	$tRCIP/7 \times 2.8$	$tRCIP/7 \times 3$	$tRCIP/7 \times 3.2$	nsec	
Input Data 4	tRIP4	$tRCIP/7 \times 3.8$	$tRCIP/7 \times 4$	$tRCIP/7 \times 4.2$	nsec	
Input Data 5	tRIP3	$tRCIP/7 \times 4.8$	$tRCIP/7 \times 5$	$tRCIP/7 \times 5.2$	nsec	
Input Data 6	tRIP2	$tRCIP/7 \times 5.8$	$tRCIP/7 \times 6$	$tRCIP/7 \times 6.2$	nsec	

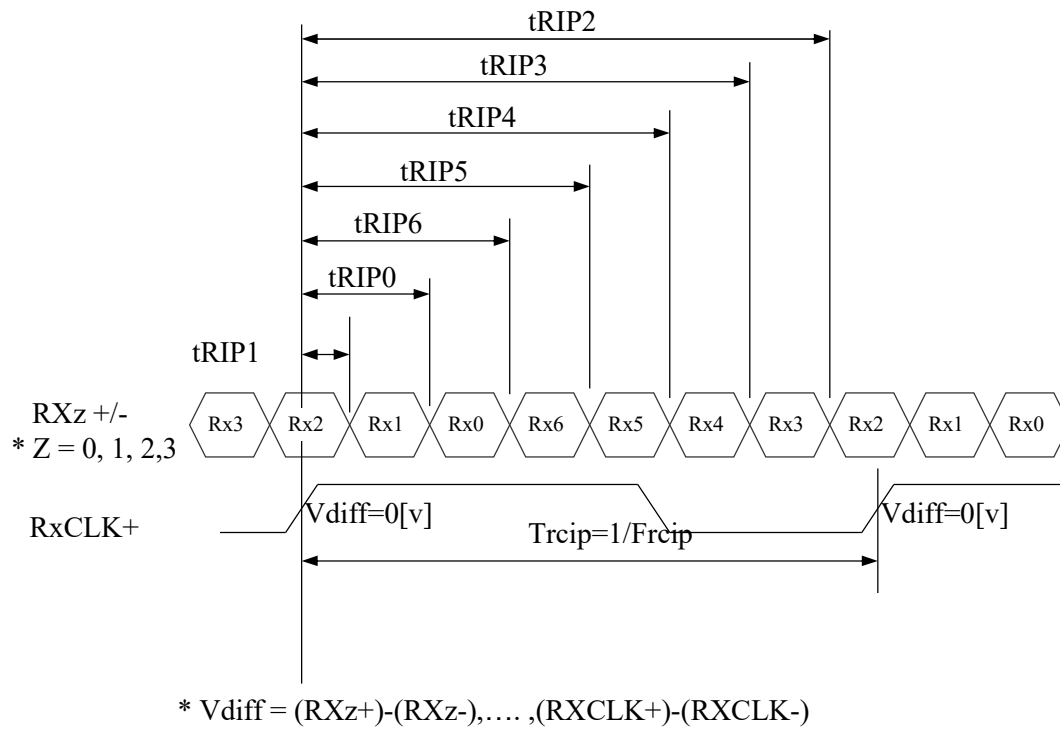



<Table 7. LVDS DC Timing Specification>

Item	Symbol	Condition	MIN	TYP	MAX	Unit
Differential input high Threshold voltage	V _{th}	V _{cm} =1.2V	-	-	+0.1	V
Differential input low Threshold voltage	V _{tl}	-	-0.1	-	-	V
Differential input common Threshold voltage	V _{cm}	-	1	1.2	1.7- V _{id} /2	V
LVDS input voltage	V _{inlv}	-	0.7	-	1.7	V
Differential input voltage	V _{id}	-	0.35	-	0.6	V
Differential input leakage voltage	I _{lvleak}	-	-10	-	+10	uA

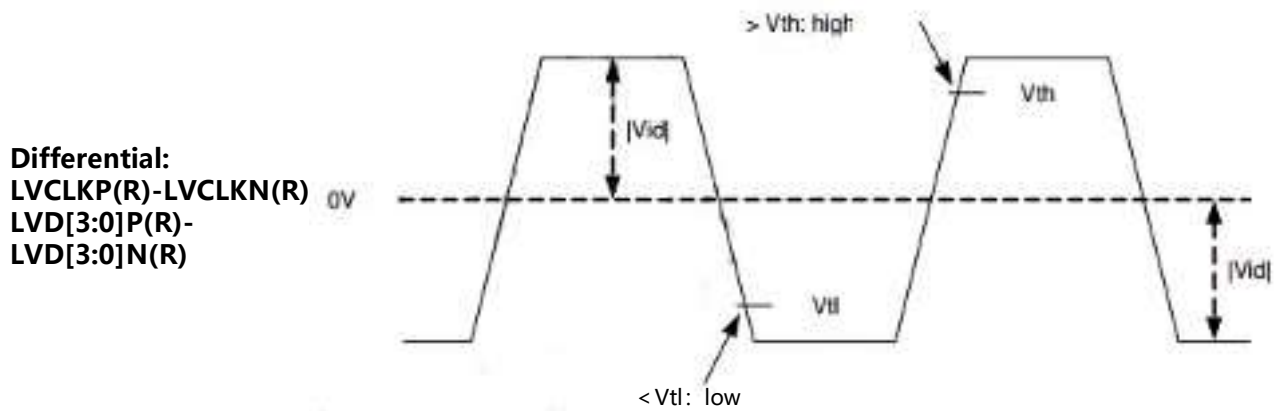



3.4 Power Sequence

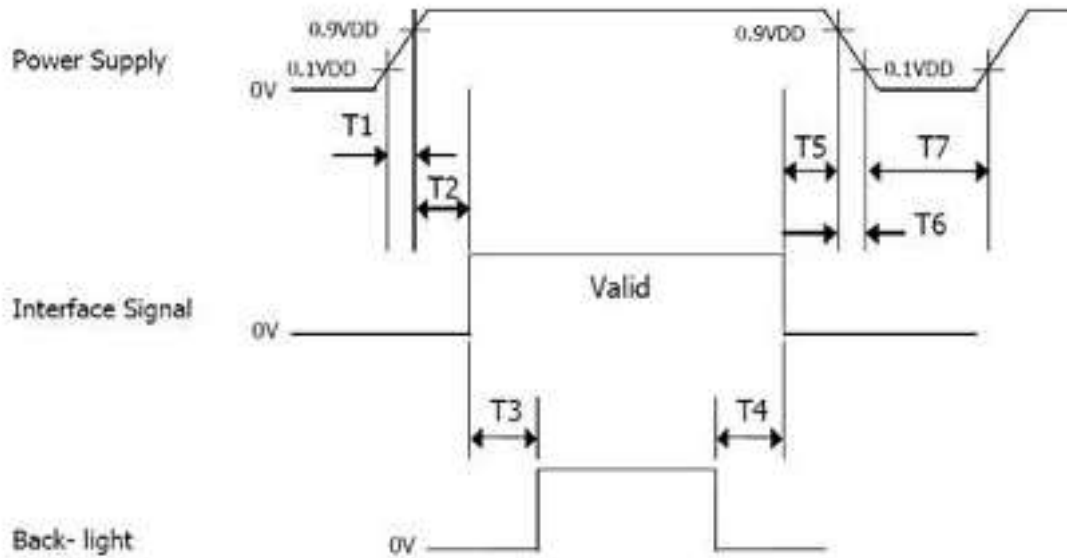

< Table8. Sequence Table >

Parameter	Values			Units
	Min	Typ	Max	
T1	0	-	10	ms
T2	0	-	50	ms
T3	200	-	-	ms
T4	500	-	-	ms
T5	0	-	50	ms
T6	0	-	10	ms
T7	500	-	-	ms

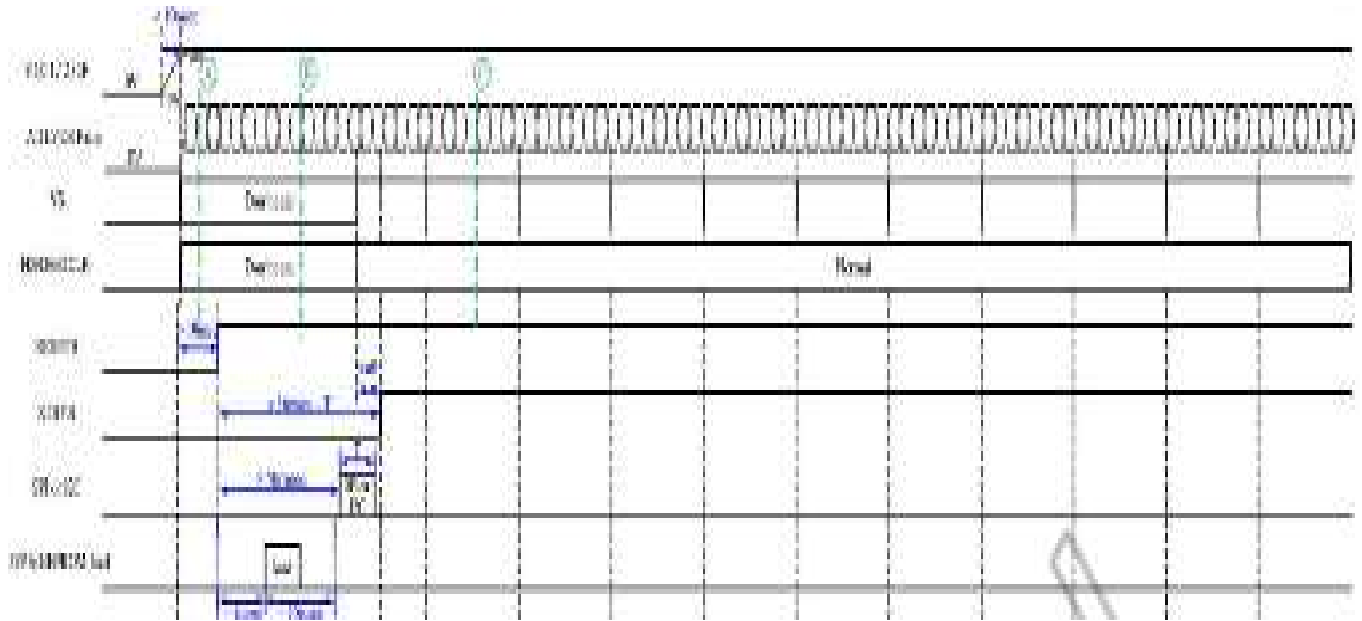



4.0 OPTICAL SPECIFICATIONS

4.1 Overview

The test of optical specifications shall be measured in a dark room (ambient luminance ≤ 1 lux and temperature = $25 \pm 2^\circ\text{C}$) with the equipment of Luminance meter system (Gonio meter system and TOPCON BM-5) and test unit shall be located at an approximate distance 50cm from the LCD surface at a viewing angle of θ and Φ equal to 0° . We refer to $\theta_0 = 0 (= \theta_3)$ as the 3 o' clock direction (the "right"), $\theta_0 = 90 (= \theta_{12})$ as the 12 O' clock direction ("upward"), $\theta_0 = 180 (= \theta_9)$ as the 9 O' clock direction ("left") and $\theta_0 = 270 (= \theta_6)$ as the 6 O' clock direction ("bottom"). While scanning θ and/or Φ , the center of the measuring spot on the Display surface shall stay fixed.

4.2 Optical Specifications < Table9. Optical Table >

Item	Symbol	Condition	Min	Typ.	Max	Unit	Note
Viewing Angle	θ_L	$Cr \geq 10$	70	80	--	deg	Note 1
	θ_R		70	80	--		
	ψ_T		70	80	--		
	ψ_B		70	80	--		
Contrast Ratio	Cr	$\theta = 0^\circ$ $FF = 0^\circ$	700	900		-	Note 2
Transmittance	Tr		3.61	3.85	4.08	%	
Response Time	Tr+Tf		--	30	35	Ms	Note 3
Color Coordinate of CIE1931	Rx	$\theta = 0^\circ$	-0.03	0.644	+0.03	-	@BOE BL UNote 4
	Ry			0.344			
	Gx			0.315			
	Gy			0.632			
	Bx			0.157			
	By			0.054			
	Wx			0.285			
	Wy			0.327			
NTSC Ratio	NTSC	CIE1931	--	72	--	%	@BOE BL UNote 5
Polarization Direction of Front Polarizer	PdF	-		0		deg	Absorpti on axis
Polarization Direction of Rear Polarizer	PdR			90		deg	Note 6



Note 1: The definition of Viewing Angle

Refer to the graph below marked by θ and ϕ .

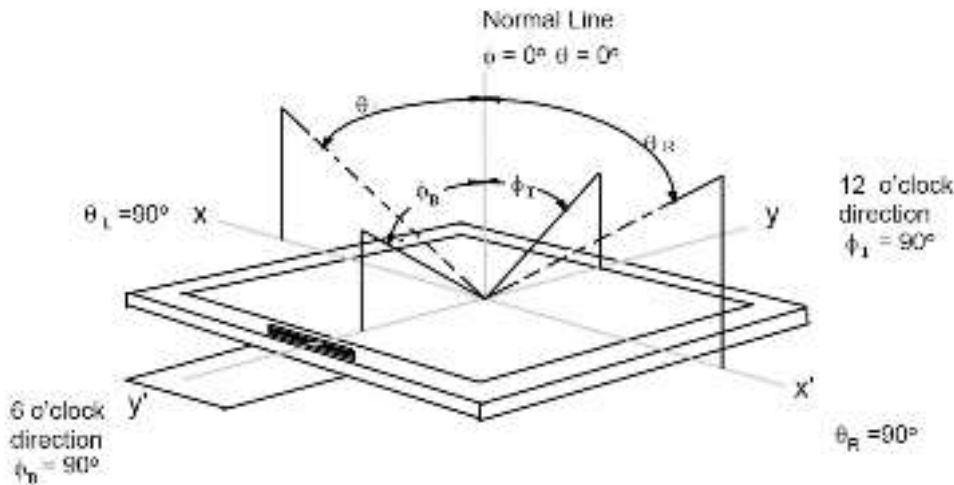

Note 2: The definition of Contrast Ratio

$$\text{Contrast Ratio (CR)} = \frac{\text{Luminance When LCD is at "White" state}}{\text{Luminance When LCD is at "Black" state}}$$

(Contrast Ratio is measured in optimum common electrode voltage)

Note 3: Definition of Response time. (Test LCD using RD80S or similar equipments):

The output sign also photo detector are measured when the input sign also are changed from "black" to "white" (Voltage falling time) and from "white" to "black" (Voltage rising time), respectively. The response time is defined as the time interval between the 10% and 90% of amplitudes. Refer to figures below.

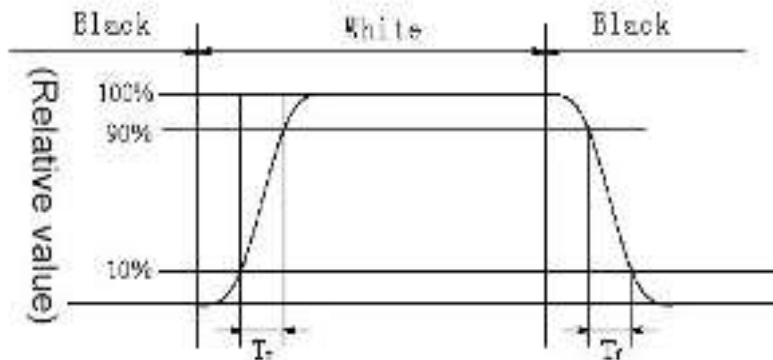

Note 4: Color Coordinates of CIE 1931

The test condition is at ILED=20mA and measured on the surface of LCD module at 25°C.

Measurement equipment: CS2000 or similar equipments

The Color Coordinate (CIE 1931) is the measurement of the center of the display shown in below figure.



Note 5: Definition of Color of CIE Coordinate and NTSC Ratio.

$$S = \frac{\text{area of RGB triangle}}{\text{area of NTSC triangle}} \times 100\%$$

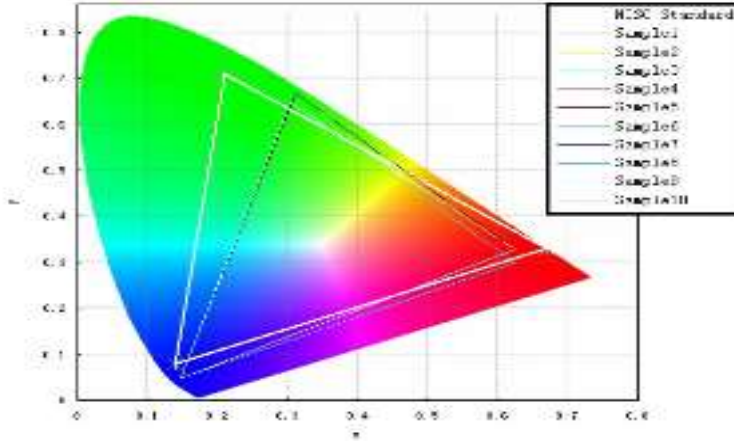

Note 6: Polarization Direction Definition

- Viewing direction is normal user viewing direction which is vertical to the display surface
- The polarizer which is closer to viewer is defined as Front Polarizer
- The polarizer which is on the rear side of viewer is defined as Rear Polarizer
- The X axis is defined as parallel line to top & bottom sidelines of the Active Area
- PdF which is marked in blue arrow is polarization degree of Front polarizer
- PdR which is marked in red arrow is polarization degree of Back polarizer
- The polarization degree parameter must be indicated in range of 0deg to 180deg according to above definition

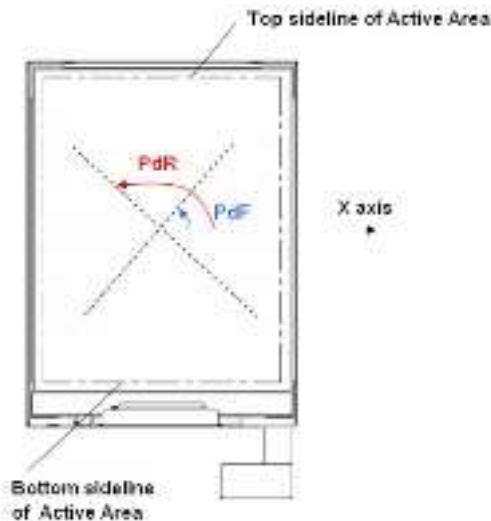



5.0 RELIABILITY TEST

The Reliability test items and its conditions are shown in below.

<Table 10. Reliability Test Parameters >

No	Test Items	Conditions
1	High temperature storage test	80°C 240hr
2	Low temperature storage test	-30°C 240hr
3	Low temperature operation test	-20°C 240hr
4	High temperature operation test	70°C 240hr
5	High temperature & high humidity (operation test)	60°C 90%RH 240hr
6	Thermal Shock Test	-20°C~80°C 0.5hr/cycle 100cycle
7		
8		
9		
10		
...		



6.0 PACKING INFORMATION(产品形态: LCMJ)

Packing procedure: T.B.D

6.1 Packing Note(产品形态 : LCM)

T.B.D



7.0 Handling & Cautions

7.1 Mounting Method

- The panel of the LCD consists of two thin glasses with polarizers which easily get damaged. So extreme care should be taken when handling the LCD.
- Excessive stress or pressure on the glass of the LCD should be avoided. Care must be taken to insure that no torsional or compressive forces are applied to the LCD unit when it is mounted.
- If the customer's set presses the main parts of the LCD, the LCD may show the abnormal display. But this phenomenon does not mean the malfunction of the LCD and should be pressed by the way of mutual agreement.
- To determine the optimum mounting angle, refer to the viewing angle range in the specification for each model.
- Mount a LCD module with the specified mounting parts.

7.2 Caution of LCD Handling and Cleaning

- Since the LCD is made of glass, do not apply strong mechanical impact or static load onto it. Handling with care since shock, vibration, and careless handling may seriously affect the product. If it falls from a high place or receives a strong shock, the glass may be broken.
- The polarizers on the surface of panel are made from organic substances. Be very careful for chemicals not to touch the polarizers or it leads the polarizers to be deteriorated.
- If the use of a chemical is unavoidable, use soft cloth with solvent (recommended below) to clean the LCD's surface with wipe lightly.
-IPA(Isopropyl Alcohol), Ethyl Alcohol, Trichlorotrifluoroethane
- Do not wipe the LCD's surface with dry or hard materials that will damage the polarizers and others. Do not use the following solvent.
-Water, Ketone, Aromatics
- It is recommended that the LCD be handled with soft gloves during assembly, etc. The polarizers on the LCD's surface are vulnerable to scratch and thus to be damaged by sharp particles.
- Do not drop water or any chemicals onto the LCD's surface.
- A protective film is supplied on the LCD and should be left in place until the LCD is required for operation.
- The ITO pad area needs special careful caution because it could be easily corroded. Do not contact the ITO pad area with HCFC, Soldering flux, Chlorine, Sulfur, saliva or fingerprint. To prevent the ITO corrosion, customers are recommended that the ITO area would be covered by UV or silicon.



7.3 Caution Against Static Charge

- The LCD modules use C-MOS LSI drivers, so customers are recommended that any unused input terminal would be connected to Vdd or Vss, do not input any signals before power is turn on, and ground you body, work/assembly area, assembly equipments to protect against static electricity.
- Remove the protective film slowly, keeping the removing direction approximate 30-degree not vertical from panel surface, If possible, under ESD control device like ion blower, and the humidity of working room should be kept over 50%RH to reduce the risk of static charge.
- Avoid the use work clothing made of synthetic fibers. We recommend cotton clothing or other conductivity-treated fibers.
- In handling the LCD, wear non-charged material gloves. And the conducting wrist to the earth and the conducting shoes to the earth are necessary.

7.4 Caution For operation

- It is indispensable to drive the LCD within the specified voltage limit since the higher Voltage than the limit causes the shorter LCD's life. An electro-chemical reaction due to DC causes undesirable deterioration of the LCD so that the use of DC drive should avoid.
- Do not connect or disconnect the LCD to or from the system when power is on.
- Never use the LCD under abnormal conditions of high temperature and high humidity.
- When expose to drastic fluctuation of temperature (hot to cold or cold to hot) ,the LCD may be affected; Specifically, drastic temperature fluctuation from cold to hot ,produces dew on the LCD's surface which may affect the operation of the polarizer and the LCD.
- Response time will be extremely delayed at lower temperature than the operating temperature range and on the other hand at higher temperature LCD may turn black at temperature above its operational range. However those phenomena do not mean malfunction or out of order with the LCD. The LCD will revert to normal operation once the temperature returns to the recommended temperature range for normal operation.
- Do not display the fixed pattern for a long time because it may develop image sticking due to the LCD structure. If the screen is displayed with fixed pattern, use a screen saver.



7.5 Packaging

- Modules use LCD element, and must be treated as such.
 - Avoid intense shock and falls from a height.
 - To prevent modules from degradation, do not operate or store them exposed directly to sunshine or high temperature/humidity for long periods.

7.6 Storage

- A slight dew depositing on terminals is a cause for electro-chemical reaction resulting in terminal open circuit. Relative humidity of the environment should therefore be kept below 60%RH.
- Original protective film should be used on LCD' s surface (polarizer). Adhesive type protective film should be avoided, because it may change color and/or properties of the polarizers.
- Do not store the LCD near organic solvents or corrosive gasses.
- Keep the LCD safe from vibration, shock and pressure.
- Black or white air-bubbles may be produced if the LCD is stored for long time in the lower temperature or mechanical shocks are applied onto the LCD.
- In the case of storing for a long period of time for the purpose or replacement use, the following ways are recommended.
 - Store in a polyethylene bag with sealed so as not to enter fresh air outside in it.
 - Store in a dark place where neither exposure to direct sunlight nor light is.
 - Keep temperature in the specified storage temperature range.
 - Store with no touch on polarizer surface by the anything else. If possible, store the LCD in the packaging situation LCD when it was delivered.

7.7 Safety

- For the crash damaged or unnecessary LCD, it is recommended to wash off liquid crystal by either of solvents such as acetone and ethanol an should be burned up later.
- In the case the LCD is broken, watch out whether liquid crystal leaks out or not. If your hands touch the liquid crystal, wash your hands cleanly with water an soap as soon as possible.
- If you should swallow the liquid crystal, first, wash your mouth thoroughly with water, then drink a lot of water and induce vomiting, and then, consult a physician.
- If the liquid crystal should get in your eyes, flush your eyes with running water for at least fifteen minutes.
- If the liquid crystal touches your skin or clothes, remove it and wash the affected part of your skin or clothes with soap and running water.



8.0 APPENDIX

Mechanical Drawing

Drawing Attachment: Front :FOG

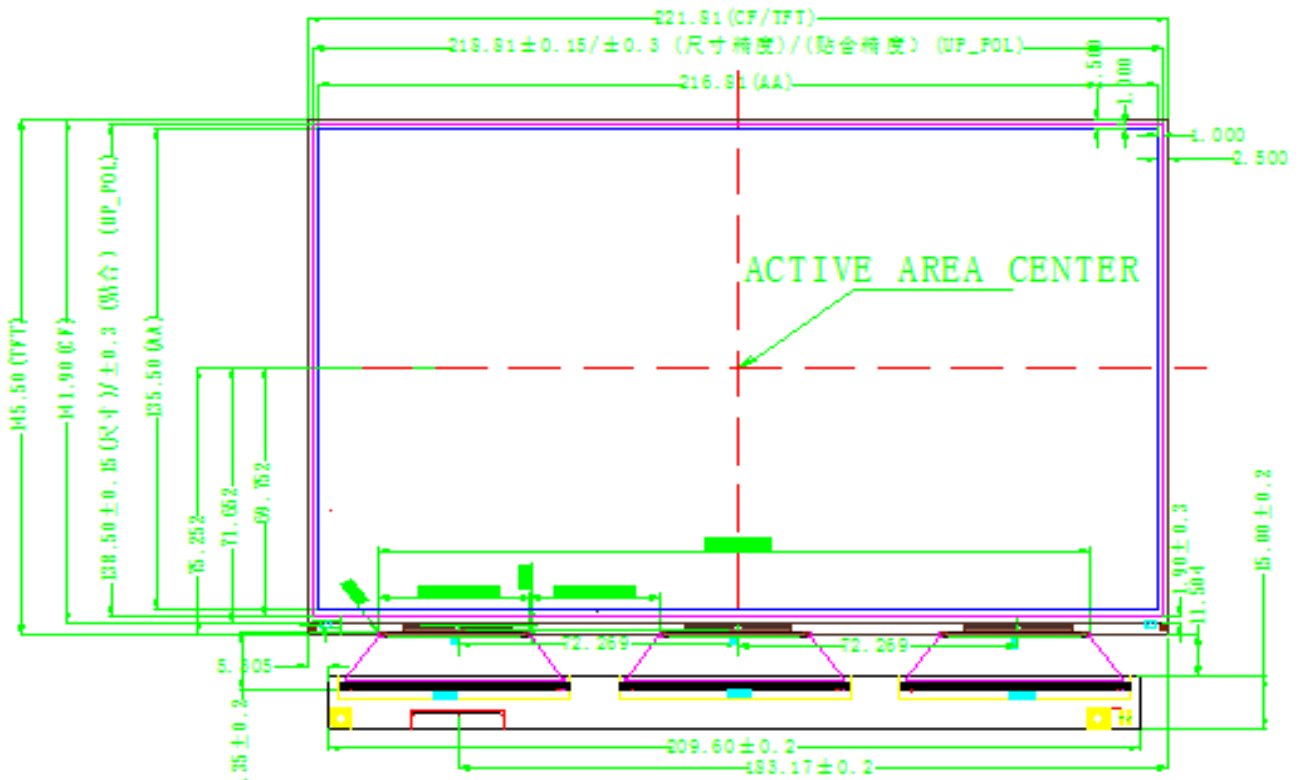



Mechanical Drawing: LCM

由 Autodesk 教育版产品制作

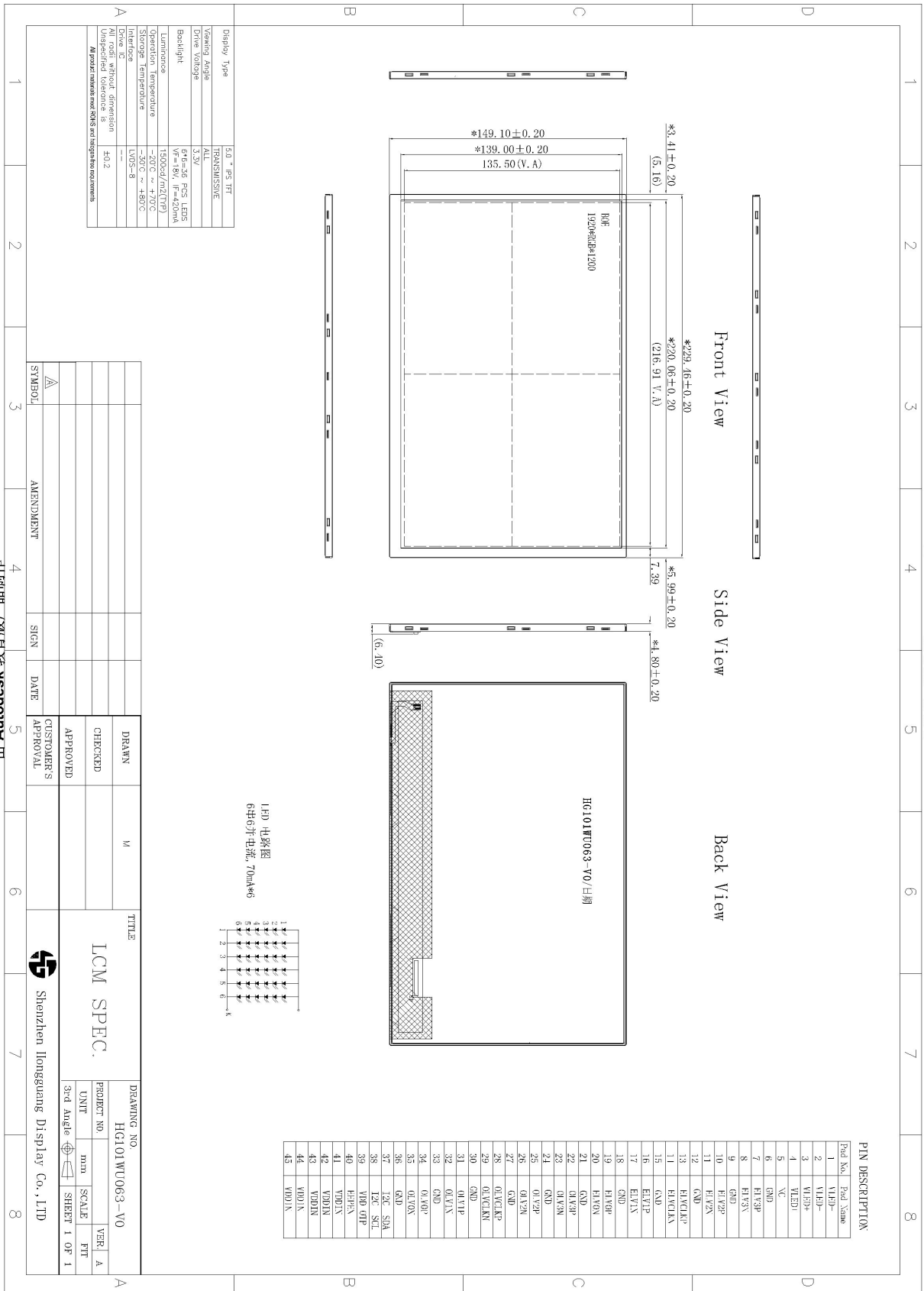

由 Autodesk 教育版产品制作

由 Autodesk 教育版产品制作

由 Autodesk 教育版产品制作