



SPECIFICATION FOR TFT LCD MODULE

CUSTOMER : _____

CUSTOMER MODULE : _____

HL MODEL : HG070WS048



■ Final Specification

Customer Confirmation column:

_____ Dept. : _____ Data : _____

Please return one of the copies of the specification with your signature to us within two weeks after you receive this document. If it is not returned, we will assume that you agree to the entire contents of this specification document.

Designed by	Checked by	Approved by



Revision History

Version NO.	DATE	Description	Remak
V1.0	2022.04.25	FIRST ISSUE	



TABLE OF CONTENT

- GENERAL SPECIFICATIONS
- ABSOLUTE MAXIMUM RATINGS
- ELECTRICAL CHARACTERISTICS
- DIMENSIONAL DRAWING
- INTERFACE PIN CONNECTIONS
- TIMING CHARACTERISTICS OF INPUT SIGNAL
- ELECTRO-OPTICAL CHARACTERISTICS
- RELIABILITY
- INSPECTION STANDARDS
- PACKING DRAWING
- HANDLING PRECAUTION



1.0 General Specifications

HG070WS048 color active matrix LCD module incorporating amorphous silicon TFT (Thin Film Transistor). It is composed of a color TFT-LCD panel, driver IC, FPC and a back light unit. The module display area contains 1024x 600pixels. This product accords with RoHS environmental criterion.

Item	Contents	Unit
Viewing direction	Full perspective	
Number of Pixels	1024(RGB) x600	/
Number of color	16.7M	/
Display Mode	Normally White	/
Backlight Type	3*9chips white LED	/
Interface Type	Parallel RGB 24-bit	/
LCM Luminance	350(typ)	cd/m2
Response Time (Tr+Tf)	25ms (typ)	
Contrast Ratio	200(typ)	
Input voltage	3.3	V



2.0 ABSOLUTE MAXIMUM RATINGS

The following are maximum values which, if exceeded may cause faulty operation or damage to the unit

Item	Symbol	Min	Max	Unit	Note
Digital Supply Voltage	VDD VDD-LVDS	-0.3	5	V	
Analog Supply Voltage	AVDD	-0.5	15	V	
Gate On Voltage	VGH	-0.3	40	V	
Gate Off Voltage	VGL	-20	0.3	V	
Gate On-Gate Off Voltage	VGH-VGL	-0.3	40	V	

Note :If users use the product out off the environment operation range (temperature and humidity ,it will have visual quality concerns.

3.0 ELECTRICAL CHARACTERISTICS

3.1 Typical Operation Condition

Item	Symbol	Min.	TYP	Max.	Unit	NOTE
Digital Power Supply Voltage For LCD	VDD	3.0	3.3	3.6	V	
Analog Power Supply Voltage	AVDD	8.5	8.7	8.9	V	-
TFT Gate on voltage	VGH	22	23	24	V	
TFT Gate off voltage	VGL	-7.4	-6.8	-6.2	V	
Common Voltage	VCOM	2.2	2.4	2.6	V	
Logic Input Voltage	VIH	0.7*DVDD		DVDD	V	
	VIL	GND		0.3*DVDD	V	

3.2 BACKLIGHT CHARACTERISTICS

Item	Symbol	Min	Typ	Max	Unit	Condition
Forward voltage	Vf	9.0	9.6	10.5	V	If=180mA
Luminance	Lv	320	350	-	cd/m2	If=180mA
Number of LED	--	27			Piece	--
Connection mode	P	3 chips serial *9			--	--



4.0 DIMENSIONAL DRAWING

由 Autodesk 教育版产品制作

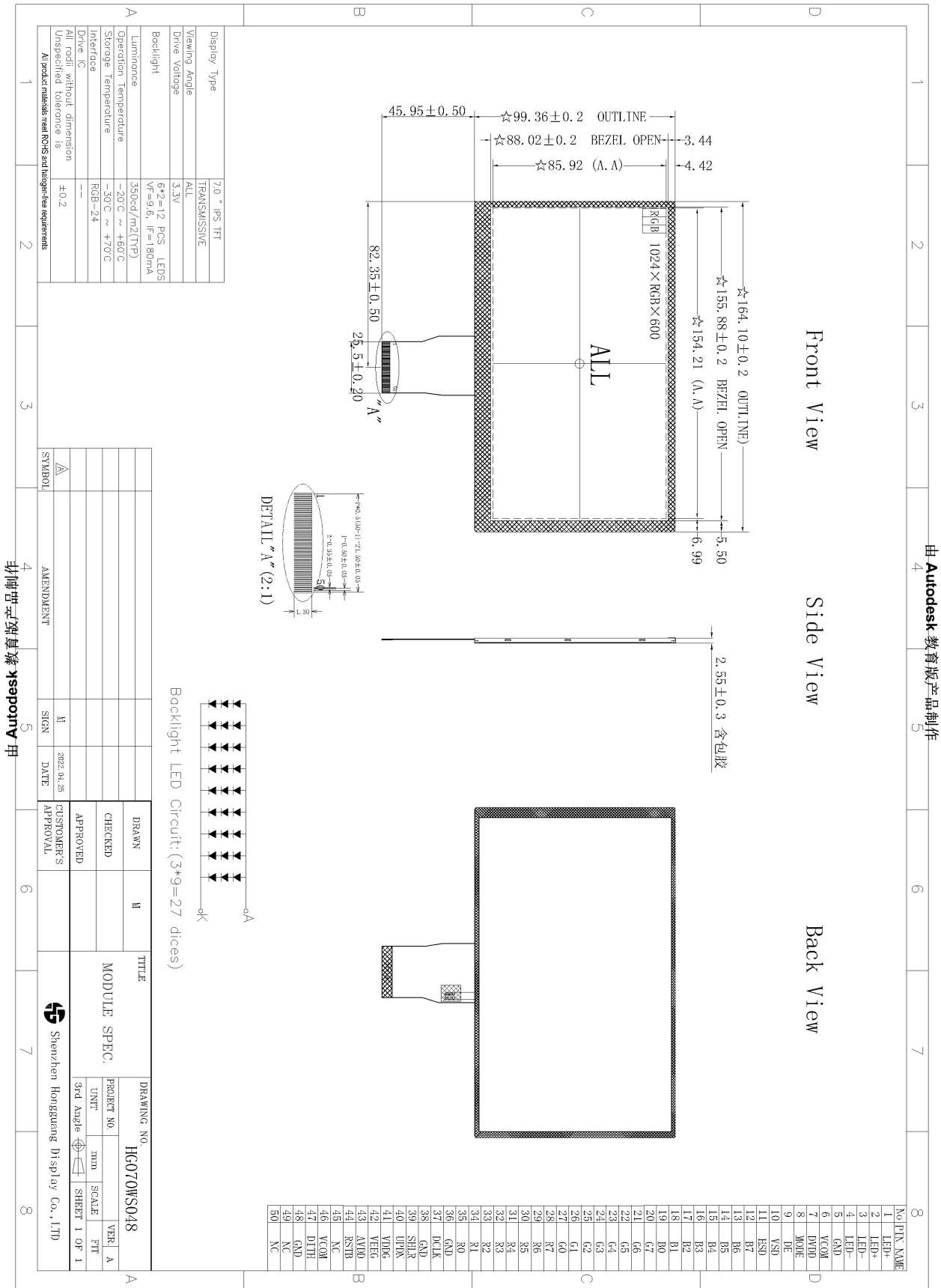

由 Autodesk 教育版产品制作

由 Autodesk 教育版产品制作



5.0 INTERFACE PIN CONNECTIONS

Pin No.	Symbol	Function
1,2	VLED+	Power for LED backlight (Anode)
3,4	VLED-	Power for LED backlight (Cathode)
5	GND	Power ground
6	VCOM	Common Voltage
7	DVDD	Digital Power
8	MODE	DE/SYNC mode select. Normally pull high H: DE mode. L: HSD/VSD mode
9:	DE	Data Enable signal.
10	VSD	Vertical sync input. Negative polarity
11	HSD	Horizontal sync input. Negative polarity
12-19	B7-B0	Blue Data
20-27	G7-G0	Green Data
28-35	R7-R0	Red Data
36	GND	Ground
37	DCLK	Colock signal
38	GND	Display on/off
39	SHLR	Left or Right Display Control
40	UPDN	Up / Down Display Control
41	VDDG	Positive Power for TFT
42	VEEG	Negative Power for TFT
43	AVDD	Analog Power
44	RSTB	Global reset pin. Active low to enter reset state. Suggest to connecting with an RC reset circuit for stability. Normally pull high. (R=10K Ω , C=1 μ F)
45	NC	Not connect
46	VCOM	Common Voltage
47	DITH	Dithering setting DITH=" H" 8bit resolution(last 2 bit of input data truncated) DITH=" L" 6bit resolution(default setting)
48	GND	Power ground
49	NC	Not connect
50	NC	Not connect



6.0 Timing characteristics

6.0. Input Timing Table

	ITEM	SYMBOL	MIN.	TYP.	MAX.	UNIT	Note
DE MODE	Dot Clock	1/tCLK	45	51.2	57	MHz	
	DCLK Pulse Duty	Tcwh	40	50	60	%	
	Horizontal Total Time	tH	1324	1344	1364	tCLK	
	Horizontal Effective Time	tHA	1024			tCLK	
	Horizontal Blank Time	tHB	300	320	340	tCLK	
	Vertical Total Time	tV	625	635	645	tH	
	Vertical Effective Time	tVA	600			tH	
SYNC MODE	Vertical Blank Time	tVB	25	35	45	tH	
	Horizontal Total Time	tH	1324	1344	1364	tCLK	
	Horizontal Pulse Width	tHPW		20	-	tCLK	tHP + tHPW = 160DCLK is fixed
	Horizontal Back Porch	tHB		140	-	tCLK	
	Horizontal Front Porch	tHFP	140	160	180	tCLK	
	Horizontal Effective Time	tHA	1024			tCLK	
	Vertical Total Time	tV	625	635	645	tH	
	Vertical Pulse Width	tVPW		3	-	tH	tVPW + tVB = 23tH is fixed
Vertical Back Porch	tVB	-	20	-	tH		
Vertical Front Porch	tVFP	2	12	22	tH		
Vertical Valid	tVD		600			tH	

6.0.2 Clock and Data Timing Diagram

Parameter	Symbol	Spec.			Unit	Condition
		Min.	Typ.	Max.		
DVDD Power On Slew Rate	TPOR	-	-	20	ms	From 0V to 90% DVDD
RSTB Pulse Width	TRst	50	-	-	us	DCLK=65MHz
DCLK Cycle Time	Tcph	14	-	-	ns	
DCLK Pulse Duty	Tcwh	40	50	60	%	
VSD Setup Time	Tvst	5	-	-	ns	
VSD Hold Time	Tvhd	5	-	-	ns	
HSD Setup Time	Thst	5	-	-	ns	
HSD Hold Time	Thhd	5	-	-	ns	
Data Setup Time	Tdsu	5	-	-	ns	D0[7:0], D1[7:0], D2[7:0] to DCLK
Data Hold Time	Tdhd	5	-	-	ns	D0[7:0], D1[7:0], D2[7:0] to DCLK
DEN Setup Time	Tesu	5	-	-	ns	
DEN Hold Time	Tehd	5	-	-	ns	

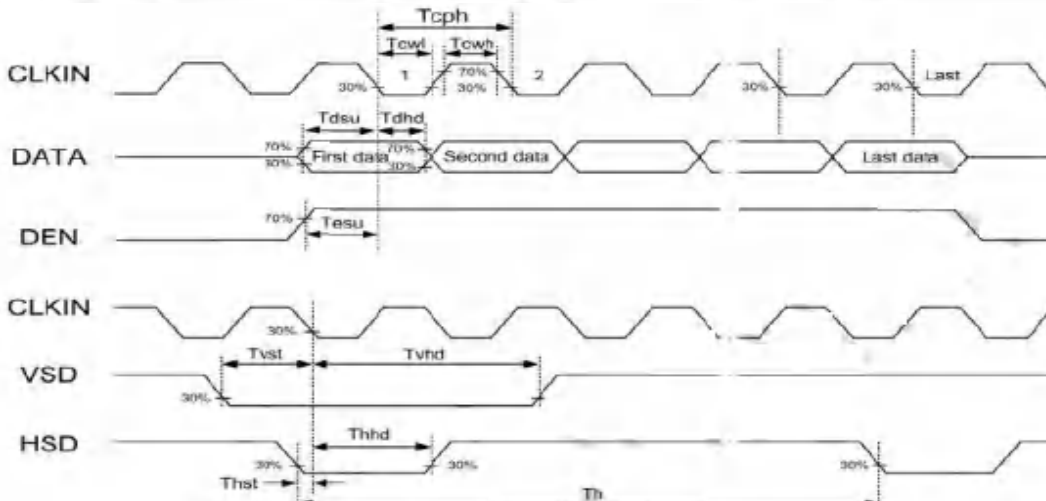



Vertical timing :

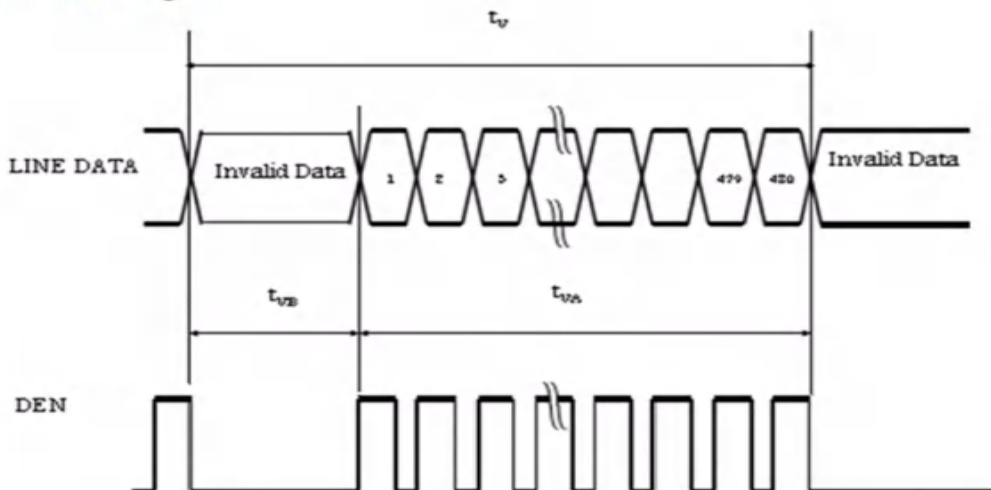

SYNC Mode

Horizontal timing :

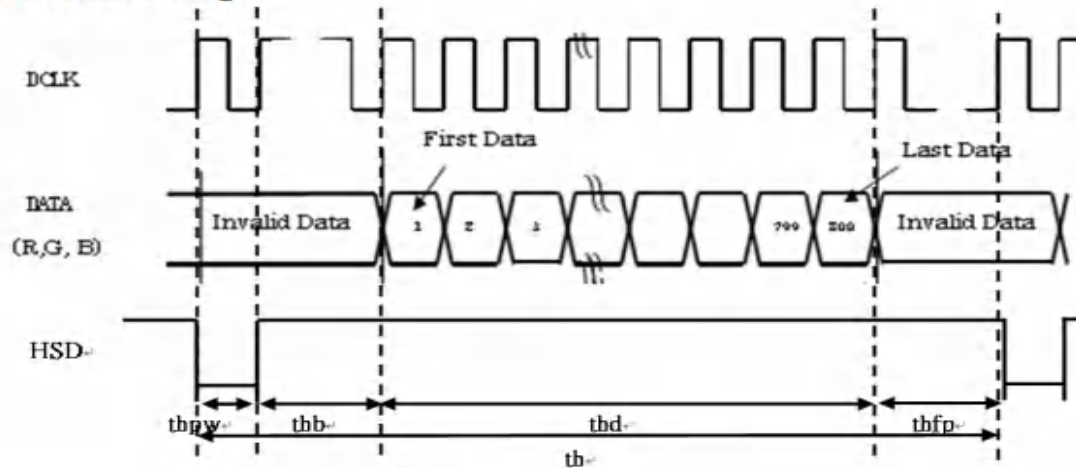



Data Input Format

Horizontal timing :

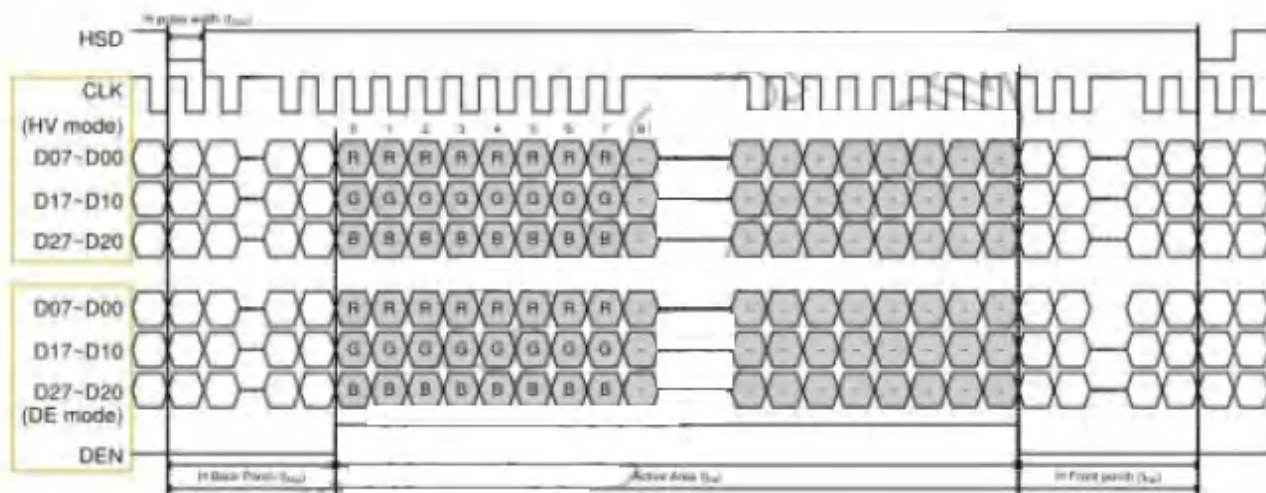

Vertical timing :

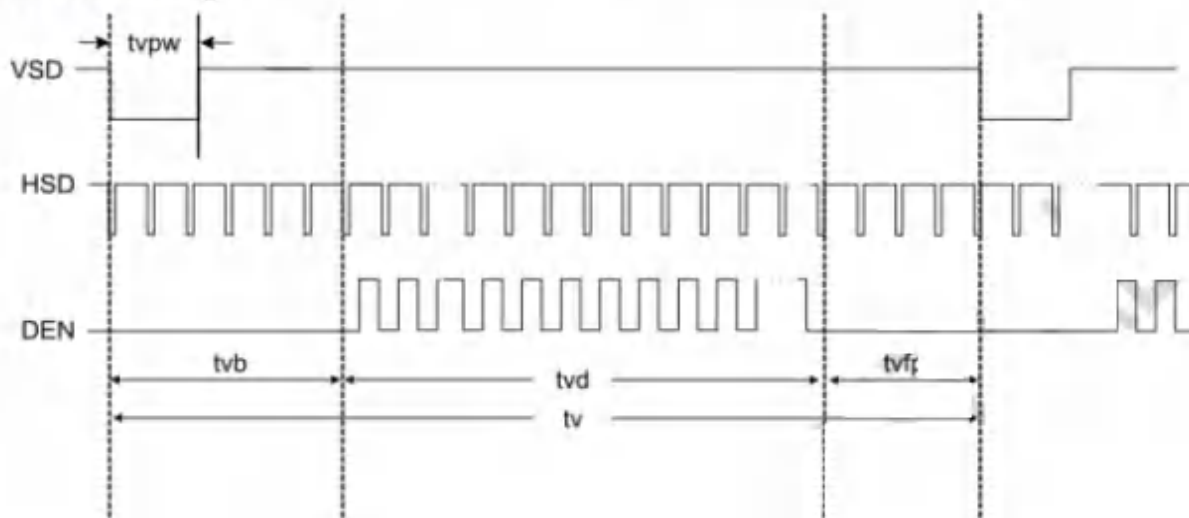

Vertical timing :

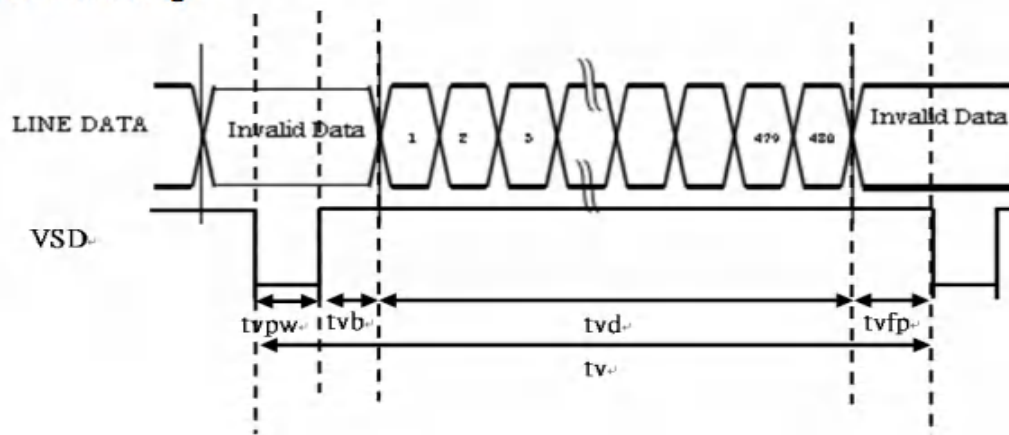



6.0.3 Power、Signal sequence

Power On : DVDD→AVDD/VGL →VGH →Video & Logic Signal→Backlight
Power Off : Backlight→Video & Logic Signal→ VGH→AVDD/VGL→DVDD

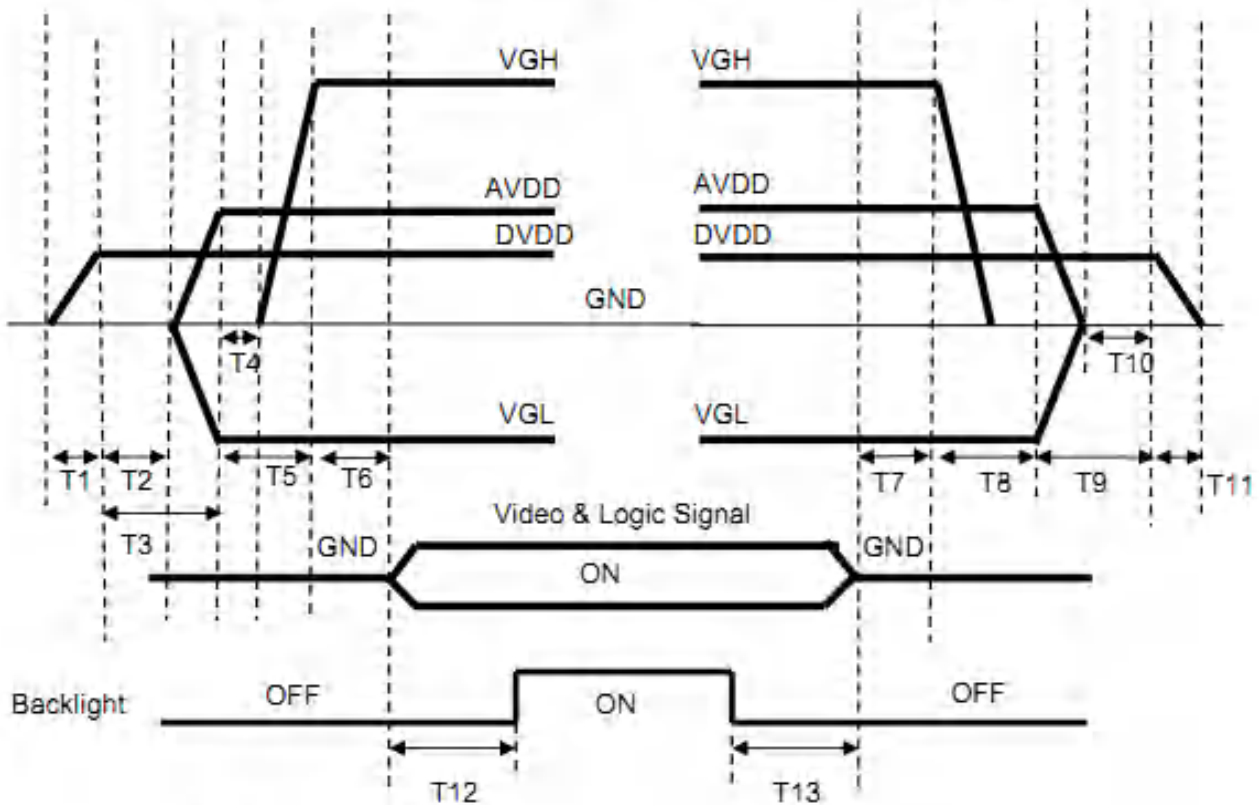

$0 < T1 \leq 10\text{ms}$
 $T2 > 0\text{ms}$
 $T3 > 20\text{ms}$
 $T4 > 0\text{ms}$
 $T5 > 10\text{ms}$
 $0 < T6 \leq 10\text{ms}$
 $T12 \geq 200\text{ms}$

$T7 > 0\text{ms}$
 $T8 > 0\text{ms}$
 $T9 > 0\text{ms}$
 $T10 > 0\text{ms}$
 $0 < T11 \leq 10\text{ms}$
 $T13 \geq 200\text{ms}$



7.0 ELECTRO-OPTICAL CHARACTERISTICS

ITEM		SYMBOL	CONDITION	MIN.	TYP.	MAX.	UNIT	NOTE
Panel Transmittance		T	$\theta = 0^\circ$	3.9	4.2	--	%	
Luminance		L	$\theta = 0^\circ$	300	350	--	cd/m ²	Note1
Luminance Uniformity		YU	9points	75	80	--	%	Note5
Contrast Ratio		CR	Point-5	--	200	--	-	Note3
Response Time		Rr+Tf	Point-5	--	25	--	ms	Note4
Viewing Angle K=Contrast Ratio>10	Horizontal	ΘL	CR > 10 $\theta = 0^\circ$	--	--	--		Note2
		ΘR		--	--	--		
	Vertical	ΘU		--	--	--		
		ΘD		--	--	--		
Color Filter Chromaticity	White	X	$\theta = 0^\circ$	0.273	0.313	0.353		Note1
		Y		0.289	0.329	0.369		
	Red	X	$\theta = 0^\circ$	TBD	TBD	TBD		
		Y		TBD	TBD	TBD		
	Green	X	$\theta = 0^\circ$	TBD	TBD	TBD		
		Y		TBD	TBD	TBD		
	Blue	X	$\theta = 0^\circ$	TBD	TBD	TBD		
		Y		TBD	TBD	TBD		
Color gamut (NTSC ratio)			$\theta = 0^\circ$		TBD		%	

Note1: Measurement Setup

The LCD module should be stabilized at given temperature for 15 minutes to avoid abrupt temperature change during measuring. In order to stabilize the luminance, the measurement should be executed after lighting backlight for 15 minutes in a windless room.

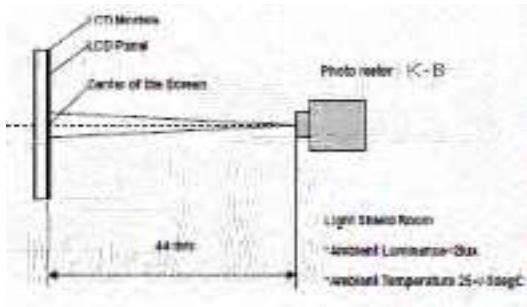

Note2: Definition of Viewing Angle

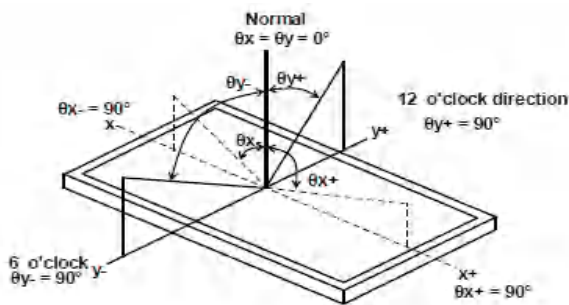

Note3: Definition of Contrast Ratio (CR)

The contrast ratio can be calculated by the following expression

$$\text{Contrast Ratio (CR)} = L_{63} / L_0$$

L63: Luminance of gray level 63, L0: Luminance of gray level 0

Note4: Definition of Response Time (TR, TF)

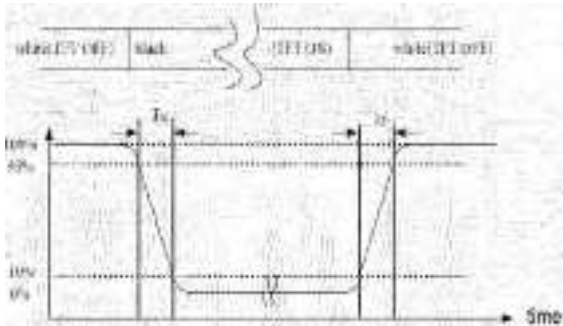

Note5: Definition of Luminance Uniformity(Variation)

Measure the luminance of gray of gray level 63 at 1-9 points

$$\blacktriangle L = [L(\text{MIN}) / L(\text{MAX})] \times 100$$

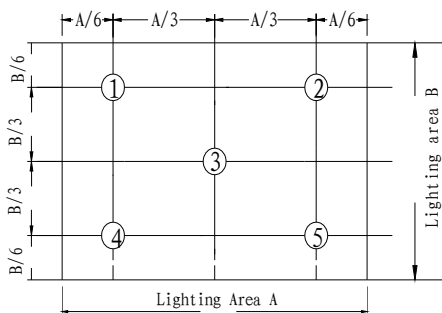



8. RELIABILITY

8.1 MTBF

The LCD module shall be designed to meet a minimum MTBF value of 50000 hours with normal. (25°C in the room without sunlight)

8.2 TESTS

NO.	Test Item	Test condition	Criterion
1	High Temperature Storage	70°C±2°C 96H Restore 2H at 25°C Power off	After testing, cosmetic and electrical defects should not happen.
2	Low Temperature Storage	-30°C±2°C 96H Restore 2H at 25°C Power off	
3	High Temperature Operation	60°C±2°C 96H Restore 2H at 25°C Power on	
4	Low Temperature Operation	-20°C±2°C 96H Restore 2H at 25°C Power on	
5	High Temperature & Humidity Operation	60°C±2°C 90%RH 96H Power on	
6	Temperature Cycle	-20°C ↔ 25°C ↔ 60°C 30min 5min 30min after 10 cycle, Restore 2H at 25°C Power off	
7	Vibration Test	10Hz~150Hz, 100m/s ² , 120min	
8	Shock Test	Half-sinewave, 300m/s ² , 11ms	
9	Drop Test(package state)	800mm, concrete floor, 1 corner, 3 edges, 6 sides each time	1. After testing, cosmetic and electrical defects should not happen. 2. the product should remain at initial place 3. Product uncovered or package broken is not permitted.
10	Electro Static Discharge Test (non-operation)	150pF, 330Ω, Contact: ±4KV, Air: ±8KV Measure point :LCD glass and metal bezel 200pF, 0Ω, ±200V contact test Measure point :IF connector pins	IEC61000-4-2: 2001 GB/T17626.2-2006



9.0 INSPECTION STANDARDS

9.1 Inspection Conditions

9.1.1 Environmental conditions

The environmental conditions for inspection shall be as follows

Room temperature: $20\pm 3^{\circ}\text{C}$; Humidity: $65\pm 20\%\text{RH}$

9.1.2 The external visual inspection

With a single 20-watt fluorescent lamp as the light source, the inspection was in the distance of 30cm or more from the LCD to the inspector's eyes .

9.2 Classification of defects

9.2.1 Major defect

A major defect refers to a defect that may substantially degrade usability for product applications.

9.2.2 Minor defect

A minor defect refers to a defect which is not considered to be able substantially degrade the product application or a defect that deviates from existing standards almost unrelated to the effective use of the product or its operation.

9.3 尺寸标准：

9.3.1 测量器具：卡尺，投影机等等；

9.3.2 检测参数：见外形尺寸图；

9.3.3 判定标准：以客户回签样品为准；

9.4 缺陷分类

9.4.1.1 严重缺陷 (CRITICAL): 会造成顾客生命, 财产损失, 引起贸易纠纷及严重影响公司信誉的不良现象。

9.4.2 重要缺陷 (MAJOR): 造成产品的功能不全, 不能达到使用功能, 或配件不全严重影响外观的缺陷。

9.4.3 次要缺点 (MINOR): 不影响产品的使用功能, 轻微的外观不良。



9.5 检验条件

9.5.1 温湿度：常温常湿。

9.5.2 光照度：外观检查环境照度要求在 1500 ± 500 LUX，功能检查环境照度要求在 400 ± 100 LUX。

9.5.3 检验位置：检验眼位置距离产品 35-40cm（如图 4-1），检验眼不超出产品垂直距离 40mm（如图 4-2）。

9.5.4 检验视角：以产品法线为中心上下左右 45° （如图 4-1）进行检查。

9.5.5 LCM 成品/LCM 半成品测试需用客供主板或能达到客户要求的测试夹具进行，FOG WIP 测试需使用到标准背光源。

9.5.6 点、线状不良的大小、长度、间距等的量测，以菲林卡覆盖检查确认，客户有特殊要求或特殊情况下使用刻度放大镜或测试设备测定；因闪烁、变幻无法准确测定的依据限度样品判定。

9.5.7 功能和外观检验时不撕除保护膜检验，功能检验在 15 ± 3 秒内完成，外观检验在 7 秒内完成。



9.5.8 检验类型

9.5.8.1 外观检验：产品在非通电状态下观察到的外观、外形、结构等。

9.5.8.2 功能检验：产品电性能、光学特性等。

9.6 显示区 A 区与 B 区的定义

A区：以屏四边为基准各向屏中心点延伸1/4区域，所剩下的中心区域视为A区（如下图所示）。

B区：以屏四边为基准各向屏中心点延伸 1/4 的区域，视为 B 区（如下图所示）

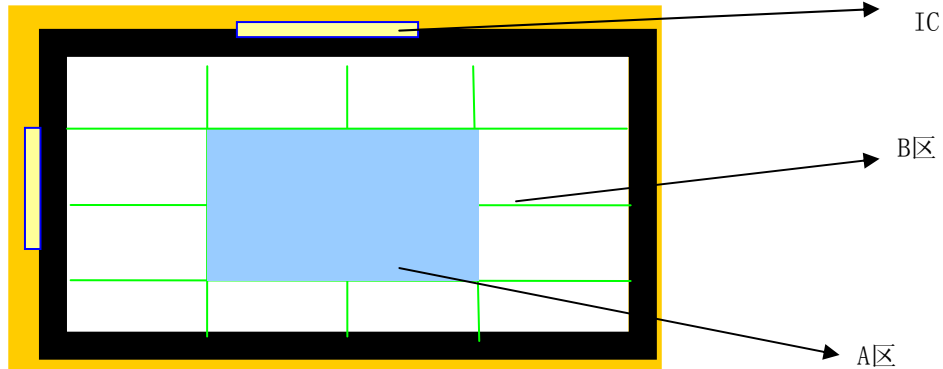

9.7 抽样方法

根据 MIL-STD-105E 一般检验水平，II 抽样计划，随机抽取方法。检查时按照功能检查 → 外观检查 → 尺寸检查 → 包装检查的顺序进行，所有的检查项目须全部合格。

9.7.1 OQC 抽样检查之允收水平 (AQL):

严重缺陷 (CRITICAL): 0;

重要缺陷 (MAJOR): 0.65;

次要缺点 (MINOR): 1.0。

9.7.2 严格转换表

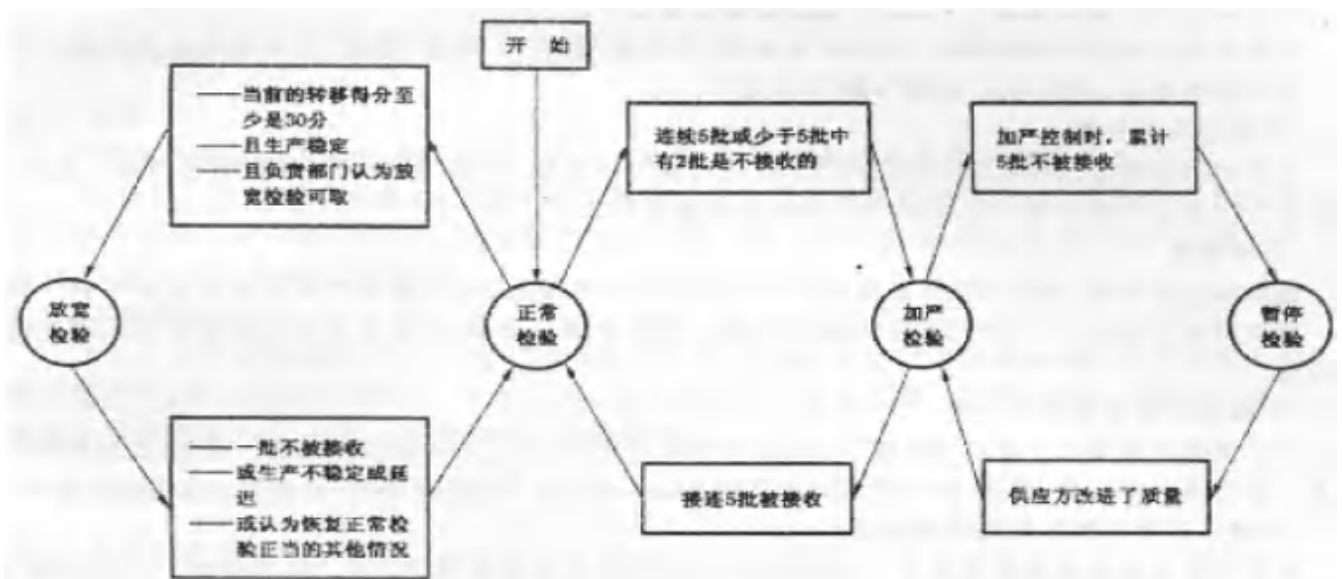



9.8 检验标准

9.8.1 功能检查规格

不良项目	LCM尺寸		判定标准		缺陷	备注
			A区	B区		
PANEL 亮点	TN	$\Phi \leq 0.15$, 不计		$\Phi > 0.15$, N=0	$0.15 < \Phi \leq 0.30$, N \leq 3; $\Phi > 0.30$, N=0	MAJ 两点间隔大于15mm, 总数不超过最大允许数
		7寸至9寸 (不含)				
		9寸以上(含9寸)	$0.15 < \Phi \leq 0.30$, N \leq 1; $\Phi > 0.30$, N=0	$0.15 < \Phi \leq 0.30$, N \leq 4; $\Phi > 0.30$, N=0		
	IPS		$\Phi \leq 0.10$, 不计	$0.10 < \Phi \leq 0.25$, N \leq 3; $\Phi > 0.25$, N=0		
PANEL 暗点	TN	$\Phi \leq 0.20$, 不计		N \leq 2	N \leq 3	MAJ
		7寸至9寸				
		9寸以上(含9寸)	N \leq 2	N \leq 4		
	IPS		$\Phi \leq 0.15$, 不计	N \leq 2	N \leq 3	
B/L 异物	TN	$\Phi \leq 0.20$, 不计		$0.20 < \Phi \leq 0.30$, N \leq 3; $\Phi > 0.30$, N=0		MAJ 不区分A、B区, 两点间隔大于15mm, 总数不超过最大允许数
		7寸至9寸 (不含)				
		9寸以上(含9寸)	$0.20 < \Phi \leq 0.40$, N \leq 4; $\Phi > 0.40$, N=0			
	IPS		$\Phi \leq 0.20$, 不计	$0.20 < \Phi \leq 0.30$, N \leq 3; $\Phi > 0.30$, N=0		
线缺陷	LCD/偏光片/TP/黑白点,线状划伤,线状异物 W \leq 0.05mm 忽略不计 0.05mm<W \leq 0.10mm & L \leq 10mm, N \leq 3; W>0.10mm & L>10mm, N=0			MAJ	/	
缺划 (彩亮线)	在任意画面看到的横线、纵线的缺失 NG			MAJ	/	
画面异常	所有的画面异常 NG			MAJ	/	
残影(阴影)	TN	检验中,画面切换到下一画面时,上一画面影像残留超4秒不能消失的NG。		MAJ	/	
	IPS	检验中,画面切换到下一画面时,上一画面影像残留超3秒不能消失的NG。				



画面闪烁	检验时出现画面忽亮忽暗或跳动现象 NG	MAJ	/
静电纹	影响画面或产品特性之静电纹 NG	MAJ	/
BL 漏光	TN 类依据限度样品。IPS 类须 0° 视角检验，不可有。	MAJ	/
白影白印	IPS 类须 0° 视角检验，不可有。	MAJ	
灯眼	点亮后 LED 灯仔发光区域比其它区域要特别亮，TN 类具体依据限度样品， IPS 类须 0° 视角检验，不可有。	MAJ	/
LED 亮度	依据产品规格书判定	MAJ	/

9.8.2 外观检查

9.8.2.1 偏光片外观检查标准

不良项目	判定标准	缺点区分	备注
POL 点状 (气泡 凹凸点)	$\Phi \leq 0.20\text{mm}$, 不计 $\Phi > 0.5\text{mm}$ N=0 0.20mm $<\Phi \leq 0.5\text{mm}$ N=3 (间隔 15mm) 边缘气泡不可进入视窗区 (不分大小和长度)	MIN	/
折痕、划伤	折痕与划伤长 $\leq 3\text{mm}$. 0, 宽 $\leq 0.03\text{mm}$ 接收 1 个, 同时必须以正常视角距产品 35 到 40CM, 直视 45 度角看不到视 OK 品, 反之 NG	MIN	/
片斜	偏光片与 LCD 边之间的距离在上、下、左、右四个方向都不可以超过黑边框的 1/2 并且完全覆盖显示区 (图纸有特别要求的除外) 偏光片张贴要附合图纸要求, 不允许超出玻璃边缘 偏光片表面脏污不允许 偏光片溢胶 $\leq 0.3\text{mm}$	MIN	/

偏光片的其它不良项目及判定标准			
不良项目	判定标准	缺点区分	备注
混片, 与 BOM 要求不符	NG	Ma j	/
保护膜脏污	轻微不影响使用的 OK	Min	/

9.8.2.2 崩角外观检查标准:

不良项目	判定标准			位置	缺点区分	备注
	L: 长 (mm)	W: 宽 (mm)	Z: 厚 (mm)			
端子 PAD 部崩缺	$L \leq 2.0$	保留黑边框的 2/3 宽度	$Z \leq t$	③	Ma j	所有崩缺不可涉及线路、不可进展性裂、不可涉及注入口
角部崩缺 t: LCD 厚度	L: 不计	保留黑边框的 2/3 宽度	$Z \leq 1/2t$	①②	Ma j	所有崩缺不可涉及线路、不可进展性裂、不可涉及注入口
其他边部崩缺	$L \leq 3.0\text{mm}$	$W \leq 0.5\text{mm}$	$Z \leq 1/2t$	①②③以外	Ma j	



所有部分的披峰	$L \leq 3.0\text{mm}$	$W \leq 0.15\text{mm}$	$Z \leq 1/2t$	所有位置	Maj	
---------	-----------------------	------------------------	---------------	------	-----	--

(形状例)

裂 有裂的缺损 一般缺损

有进展性 NG 有进展性 NG 无进展性 Size判定

崩角① 崩角② 崩边 批锋

9.8.2.3 点胶外观检查

不良项目	不良现象描述	判定标准	缺点区分	备注
点胶不良	黑胶高出偏光片溢到 FPC 上	NG	Min	/
	硅胶未覆盖住 ITO 线 硅胶盖住 IC FPC 背面的硅胶未盖住 FPC 金手指 FPC 背面的硅胶总宽度超过 3.0 mm	NG	Maj	/
	打胶断续不连贯	依据限度样品	Min	/
	硅胶污染到产品的其他部位，如偏光片、保护膜、FPC、BL 等	NG	Min	/

9.8.2.4 贴胶外观检查标准

不良项目	不良现象描述	判定标准	缺点区分	备注
胶皮规格	与 BOM 相关设计尺寸要求不相符	NG	Maj	/
高温胶贴歪	焊接点裸露未遮焊点、贴附起翘或贴到金手指上	NG	Min	/
胶皮起翘	未与黑胶粘合好，与黑胶产生脱离	NG	Min	/
胶皮贴附不良	胶皮贴附盖住 IC 贴斜进入偏光片面	NG	Min	/



9.8.2.5 包胶外观检查标准

不良项目	不良现象描述	判定标准	缺点区分	备注
包胶不良		<p>1. 遮光胶与偏光片边缘须保持一定间距，短窄边间距不大于 1.0mm</p> <p>2. 遮光胶若接触到偏光片边缘，若没有接触到保护膜则 OK。</p> <p>3. 遮光胶接触到保护膜侧边，或搭到保护膜之上，则 NG。</p> <p>4. 短窄边遮光胶不可鼓起气泡。</p>	Maj	/

9.8.2.6 BL 焊接外观检查标准

不良项目	不良现象描述	判定标准	缺点区分	备注
焊接不良	焊接偏位	上下重合度必须以 BL 引脚长度焊平焊齐为止，左右重叠面积必须达 2/3	Maj	/
	焊点高度偏短	焊点应向内成凹之形状平均附着于整个水平线上,不可有焊点锡过多,外观成外凸现象，此将无法辨别焊接是否良好，也不可锡过少，此将会造成附着强度对产品功能存在隐患 NG	Maj	/
			Maj	
	焊盘有锡珠、锡渣、锡尖	NG	Maj	/
	连锡、假/漏/冷/空焊	NG	Maj	/
	插件式焊接：焊点应向内成凹之形状，不可包焊或锡量不足	<p>良品 $0.05 < L \leq 2.0$</p> <p>过长 $L > 2.0\text{mm}$</p> <p>过短且伤及锡球 $L < 0.05\text{mm}$</p> <p>零件脚包焊</p>	Maj	/



9.8.2.7 FPC 外观检查标准

不良项目	不良现象描述	判定标准	缺点区分	备注
FPC 版本、尺寸不符合	版本错误，与 BOM 表尺寸相关设计结构不符	NG	Maj	必须与 BOM 保持一致
FPC 折、划/刮伤、打痕	表面刮伤不伤及线路，无破裂，不影响功能，背面不可见，具体可参照限度样本	参照限度样本	Min	硬划伤 NG
FPC 起泡/分层	保护膜与铜箔分层 NG；非走线区域有气泡不影响功能 OK 走线区域/铜箔区域有气泡 NG；补强板区域有气泡以拉力是否合格来判定；气泡导致补强板分离 NG	NG	Maj	/
脏污	表面有脏污或杂物（残留导电布、高温胶、锡珠、锡渣等）	NG	Min	/
元器件状况	掉件 元件破损	NG	Maj	W 表示元器件的整个长度
		元件与 FPC 元件焊点重合度左右、上下必须达 3/4	Maj	/
焊接时金手指不良	FPC 金手指残缺、变形、金手指断裂超过金手指单个 PIN 角总长度的 1/4	参照限度样本	Maj	硬折伤 NG
	BL FPC 金手指偏位	FPC 金手指与焊盘偏出的部分不能超过 P 角宽度的 1/4	Maj	/
	FPC 金手指焊垫氧化 电镀不良 断线 边缘金属翘起	NG	Maj	/
	金手指刮痕不可露镍及露底材 压痕 打痕 针痕 表面裂痕	NG	Maj	/
	金手指线路（贯通孔）不可断裂 不可有锐角折痕	NG	Maj	/
	FPC, FFC 等周边连接材料，除非原设计，不可死折	NG	Maj	/
	金手指沾锡	NG	Min	/
缺口或者撕裂	线路板处有缺口或者边缘撕裂	NG	Maj	/
毛边、披峰	边缘有突起残留	NG	Min	/
元器件焊锡不良	元器件吃锡量高于元器件本身高度小于本身高度的 1/4、有锡尖、元器件表面沾锡	NG	Maj	/
FPC 定位孔不良	位置与样板不符、孔损坏、定位孔偏移、堵塞等	NG	maj	/



9.8.2.8 铁框外观检查标准

不良项目	不良现象描述	判定标准	缺点区分	备注
铁框不良	铁框材质及规格不符合设计要求	NG	Maj	/
	铁框出现断裂、生锈、弯曲弯形	NG	Min	/
	铁框上出现不脏污、油污及指印	NG	Min	/
	铁框正面刮伤、磨伤	NG	Min	/
	电镀、烤漆与规格样品不符	NG	Min	/
	烤漆需均匀，不可出现胶漆、变色或汽泡	NG	Min	/
	铁框边缘不可有毛刺	NG	Min	/

9.8.2.9 成品喷码检查标准

不良项目	不良现象描述	判定标准	缺点区分	备注
喷码模糊	喷码字体不清楚	NG	Maj	/
漏喷码	漏喷码	NG	Maj	/
喷码内容不对	拉别/时间/型号不对或有字少字的情况	NG	Maj	/
喷码位置	与样板或与要求不符	NG	Min	/

9.8.2.10 成品尺寸检查标准

不良项目	不良现象描述	判定标准	缺点区分	备注
成品尺寸（长、宽、厚）	必须与BOM表成品结构尺寸相符	NG	Maj	/

9.8.3 包装检查标准

不良项目	不良现象描述	判定标准	缺点区分	备注
包装箱	包装箱变质，破损，打包不牢固 未进行180度交叉放置	NG	Maj	/
数量不符	与包装BOM不符（多数/少数）或与外 包装标注的数量不一致	NG	Maj	/
包装物料错误	不同机型混装一起	NG	Maj	/

※ 对于客户特别要求的项目，要特别进行检查。

9.9 不合格处理

9.9.1 在检查过程中，发现有不符合规格及文件要求的项目（拒收），要立即开出《OQC不良处理报告》给责任部门分析原因并采取改善对策，需要进行返工的还应该开出《返工报告》。生产部在提交产品给OQC检查时，必须提交《OQC不良处理报告》及《返工报告》，再检查的结果要进行记录。



10.0 PACKING DRAWING

包装图:

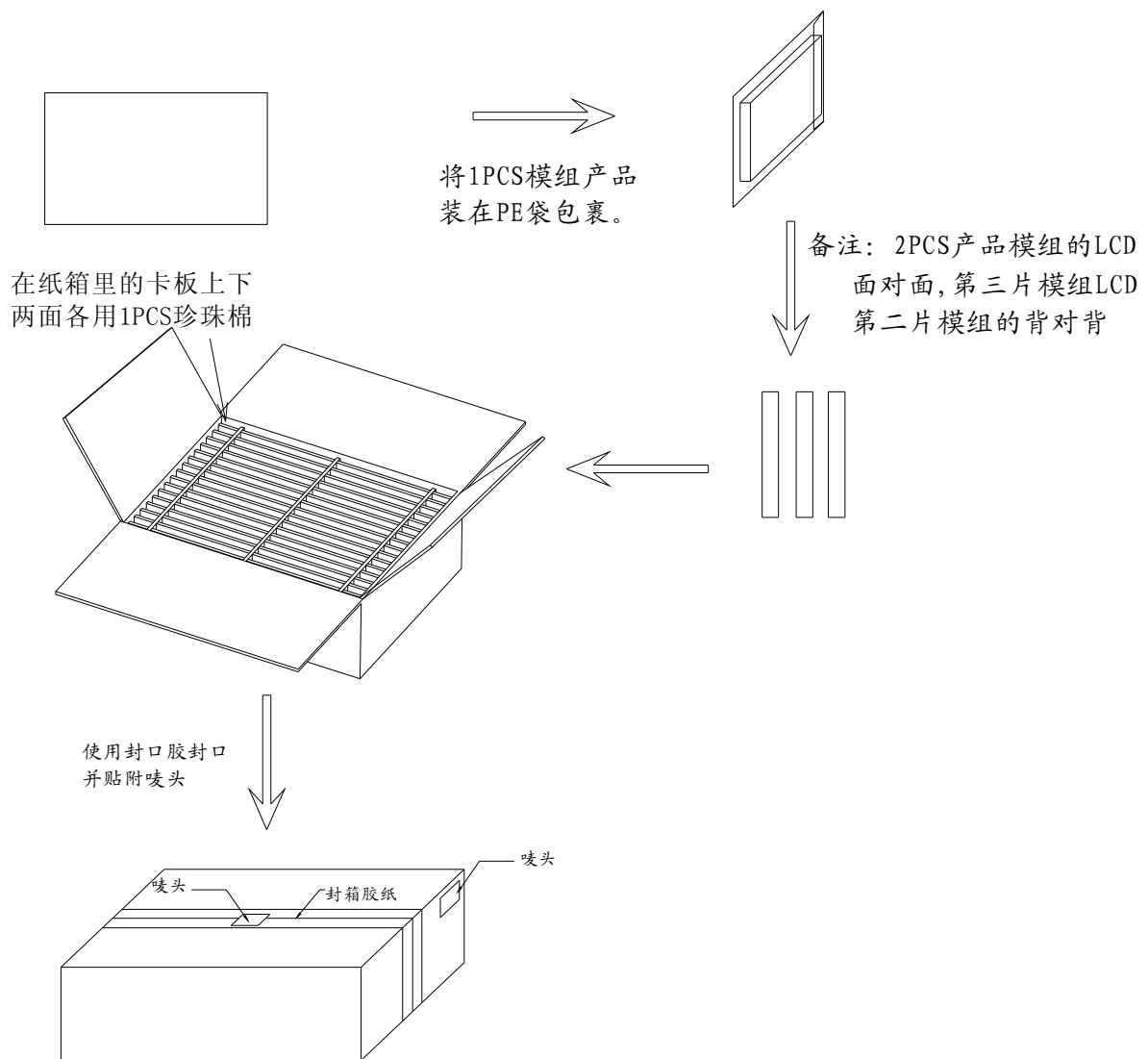

REVISION 版本	A0	<input checked="" type="checkbox"/> 正式规格 <input type="checkbox"/> 临时规格	REVISOR 修订人	MODEL NO 产品料号	APPROVED BY 核准	CHECKED BY 审核	DRAWN BY 绘图
DATE 日期	2121-11-14						
PAGE 页码	5			客户:			



11. 0 HANDLING PRECAUTION

- (1) Don't disassemble and reassemble the module by self.
(禁止自行拆解)
- (2) Acid, alkali, alcohol or touched directly by hand will damage the display.
(酸性、碱性、酒精或手的直接接触将会损伤显示面)
- (3) Static electricity will damage the module. Please configure grounding device.
(静电会损伤模组，请装配接地设备)
- (4) The strong vibration, shock, twist or bend will cause material damage, even module broken.
(强烈的撞击、震动、扭转或弯曲将会造成原材损伤，甚至面板破裂)
- (5) It is easy to cause image sticking while displaying the same pattern for very long time.
(长期显示同一画面会造成影像残留)
- (6) The response time, brightness and performance will vary from different temperature.
(响应时间、亮度与均匀性会因温度而有所改变)