



SPECIFICATION FOR TFT LCD MODULE

CUSTOMER : _____

CUSTOMER MODULE : _____

HL MODEL : HG050WV009G01

Preliminary Specification

Final Specification

Customer Confirmation column:

Approved by : _____ Dept. : _____ Data : _____

Please return one of the copies of the specification with your signature to us within two weeks after you receive this document. If it is not returned, we will assume that you agree to the entire contents of this specification document.

Designed by	Checked by	Approved by



CONTENTS

1. GENERAL SPECIFICATIONS	3
2. INPUT/OUTPUT TERMINALS	4
3. ABSOLUTE MAXIMUM RATINGS	5
4. ELECTRICAL CHARACTERISTICS	5
5. TIMING CHART	7
6. OPTICAL CHARACTERISTICS	12
7. ENVIRONMENTAL / RELIABILITY TESTS	15
8. MECHANICAL DRAWING	16
9. INSPECTION SPECIFICATION.....	17
10. PACKING	19



1. General Specifications

Feature		Spec
Display Spec	Size	5.0 inch
	Resolution	800(RGB) x 480
	Interface	LVDS
	Technology type	IPS TFT
	Pixel pitch(mm)	0.135 x 0.135
	Display colors	16.7M Dithering
	TFT Driver IC:	ST72658
	CTP Driver IC:	--
	Viewing Direction	ALL
Mechanical Characteristics	LCM(W x H x D)(mm)	165.10 x 99.10 x 7.40
	Active Area(mm)	108.00 x 64.80
	With /Without TP	Without
	Weight (g)	TBD
	LED Numbers	15 LEDS

Note 1: Viewing direction for best image quality is different from TFT definition; there is a 180 degree shift.

Note 2: Requirements on Environmental Protection: RoHS.

Note 3: LCM weight tolerance: +/-5%.



2. Input/Output Terminals

TFT CONNECONT

No.	Symbol	Description
1	GND	System Ground
2	RxOIN0-	LVDS N0 data signal
3	RxOIN0+	LVDS P0 data signal
4	GND	System Ground
5	RxOIN1-	LVDS N1 data signal
6	RxOIN1+	LVDS P1 data signal
7	GND	System Ground
8	RxOIN2-	LVDS N2 data signal
9	RxOIN2+	LVDS P2 data signal
10	GND	System Ground
11	RxOCLK-	LVDS N clock signal
12	RxOCLK+	LVDS P clock signal
13	GND	System Ground
14	RxOIN3-	LVDS N3 data signal
15	RxOIN3+	LVDS P3 data signal
16	GND	System Ground
17	NC	No connect
18	VDD	Digital power supply
19	VDD	Digital power supply
20	VDD	Digital power supply
21	RESET	Reset Pin H: normal operation L: Reset state suggest to connecting with an RC circuit for stability
22	STBYB	Standby mode H: normal operation L: TCON, SD, power circuit and temp sensor will turn off
23	NC	No connect
24	CS	Chip select signal , It should be NC for customer.If it must have a status,pls connect a resistor of 4.7K to VDD.
25	SCL	Clock signal for SPI, It should be NC for customer.If it must have a status,pls connect a resistor of 4.7K to VDD.
26	SDA	Serial data input for SPI, It should be NC for customer.If it must have a status,pls connect a resistor of 4.7K to VDD.
27	GND	System Ground
28	NC	No connect
29	GND	System Ground
30	NC	No connect
31	NC	No connect
32	TH+	Thermistor positive terminal.
33	TH-	Thermistor negative terminal,it should connect to GND.
34	NC	No connect
35	A	Backlight power Anode
36	A	Backlight power Anode



37	NC	No connect
38	K	Backlight power cathode
39	K	Backlight power cathode
40	K	Backlight power cathode

3. Absolute Maximum Ratings

Driving TFT LCD Panel

(The following are maximum values which, if exceeded, may cause operation or damage to the unit.)

Item	Symbol	Min.	Max.	Unit	Note
LC Operating Voltage	VOP	--	(5.1)	V	*1,*2
Operating Temperature	T _{OP}	-30	85	°C	
Storage Temperature	T _{ST}	-40	90	°C	
Operating Ambient Humidity	H _{OP}	10	*4	RH	*3
Storage Humidity	H _{ST}	10	*4	RH	*3

Note:

- *1. At 25±5°C
- *2. Due to the characteristics of LC Material, the Liquid Crystal driving voltage varies with environmental temperature.
- *3. Non-condensation.
- *4. Temp. ≤ 60°C, 90%RH Max.
Temp. > 60°C, Absolute humidity shall be less than 90%RH.

4. Electrical Characteristics

4.1 Driving TFT LCD Panel

4.1.1 DC Characteristics for LVDS Receiver Circuit

Single End Signals

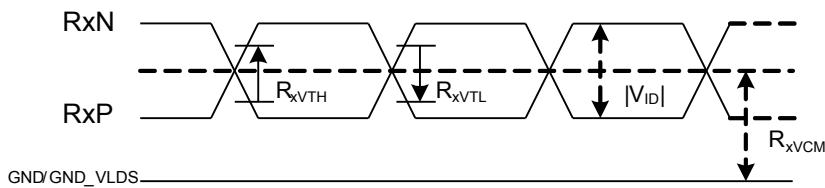

Differential Signals

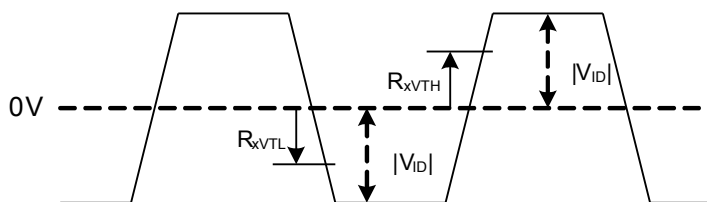



DC Electrical Characteristics (PVDD=VDD=VDDI= 3.3V, AGND= 0V, TA=25°C, Bare Chip)

Item	Symbol	Min.	Typ.	Max.	Unit	Conditions
Differential Input High Threshold Voltage	R_{xVTH}	-	-	0.1	V	$R_{xVCM} = 1.2V$
Differential Input Low Threshold Voltage	R_{xVTL}	-0.1	-	-	V	
Input Voltage Range (Singled-End)	R_{xVIN}	0	-	VDD-1.0	V	
Differential Input Common Mode Voltage	R_{xVCM}	$ V_{ID} /2$	-	$2.4- V_{ID} /2$	V	
Differential Input Voltage	$ V_{ID} $	0.2	-	0.6	V	
Differential Input Leakage Current	R_{VxIz}	-10	-	10	μA	
LVDS Digital Operating Current	I_{VDD_LVDS}	-	10	15	mA	
LVDS Digital Stand-by Current	I_{STBD_LVDS}	-	10	50	μA	
Differential Input Termination Resistance	R_{ID}	90	100	110	Ω	

4.2. Driving Backlight

Item	Symbol	MIN	TYP	MAX	Unit	Remark
Forward Current	I_F	-	240		mA	Note
Forward Voltage	V_F	13.0	15.0	17.0	V	
Backlight Power consumption	W_{BL}	-	736	-	nW	

Note: 1. The figure below shows the connection of backlight LED.

2. One LED: $I_F=80mA$, $V_F=3.1V$

3. The minimal life time of LED: 50,000 hours

Sinda will make sure only one reef of leds will be used to mount a single backlight module. On COBO PWB, supply voltage for backlight large than 17.7V must be guaranteed

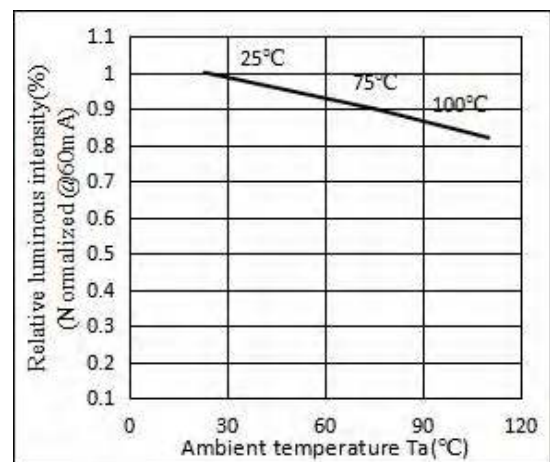
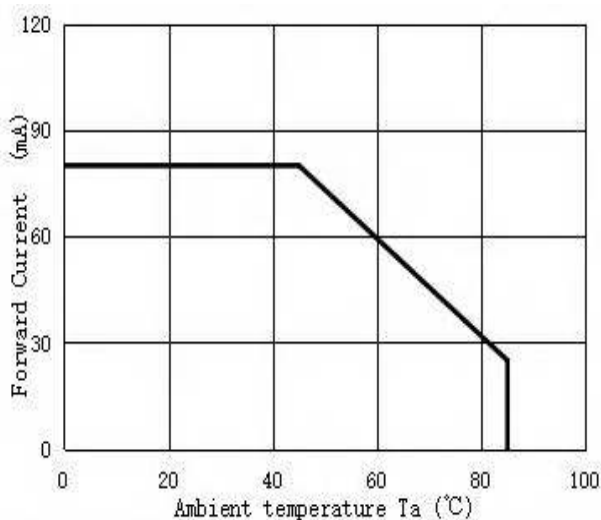

Notes: All characteristics are for reference only 所有特性仅供参考



5. Timing Chart

5.1 Timing of power on/off

Power Mode

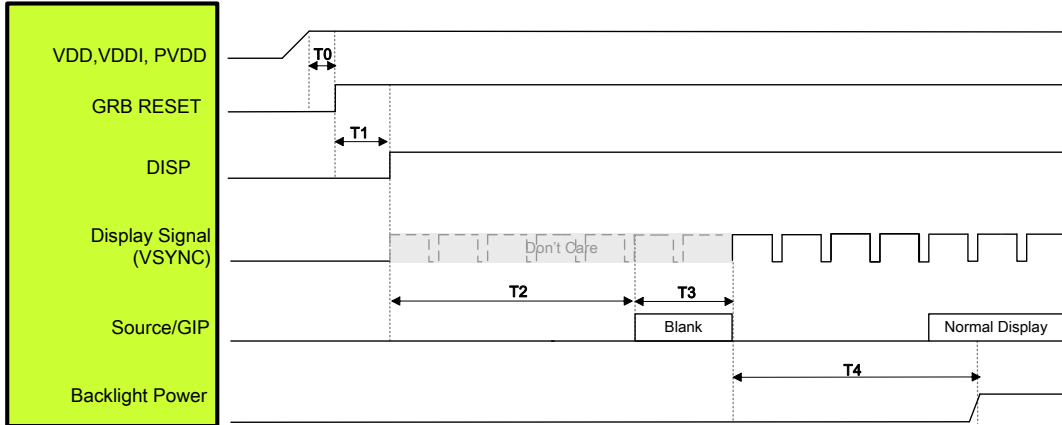

Symbol	Description	Time	Unit
T0	System power stability to GRB RESET signal	≥1	ms
T1	GRB RESET= "High" to DISP="High"	≥10	ms
T2	DISP="High" to Source/GIP scan blank	85	ms
T3	IC scan blanking signal	≥33	ms
T4	Display signal input to Backlight power on (base on Display Signal Frame Rate 60Hz)	≥100	ms

Note: 1. When DISP pull "H" or "L", IC will execute the internal power on or power off procedures. Please be careful about the timing of DISP and do not interrupt it during power on or power off procedure, otherwise unexpected errors will occur.

2. RGB interface Display signal: DCLK; VSYNC; HSYNC; DE; DR[7:0]; DG[7:0]; DB[7:0].

3. LVDS interface Display signal: DCLK P/N; RX[3:0] P/N

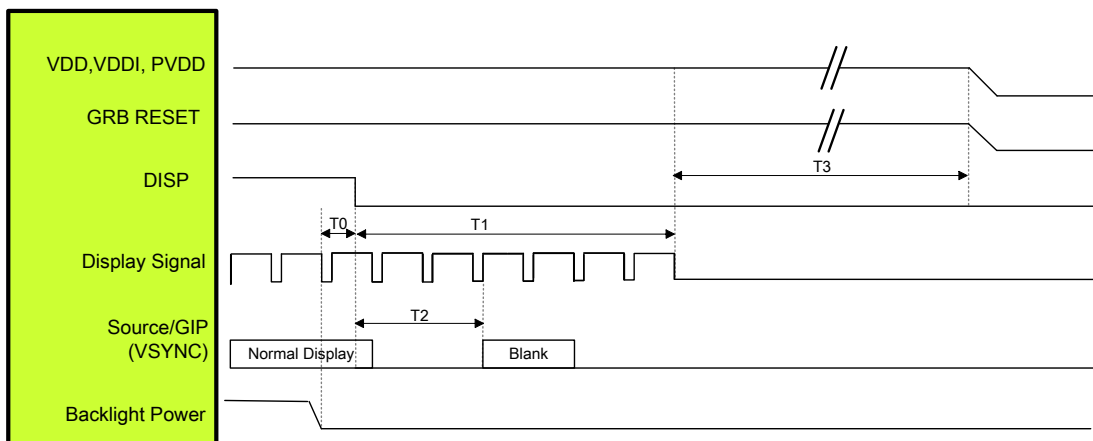



Symbol	Description	Time	Unit
T0	Backlight Power off to DISP="Low"	≥ 1	ms
T1	DISP="Low" to IC internal voltage discharge complete	≥ 100	ms
T2	DISP="Low" to Source/GIP scan blank (base on Display Signal Frame Rate 60Hz)	≤ 50	ms
T3	IC internal voltage discharge is completed to VDD/VDDI/PVDD off	≥ 0	ms

Note: 1. When DISP pull "H" or "L", IC will execute the internal power on or power off procedures. Please be careful about the timing of

DISP and do not interrupt it during power on or power off procedure, otherwise unexpected errors will occur.

2. RGB interface Display signal: DCLK; VSYNC; HSYNC; DE; DR[7:0]; DG[7:0]; DB[7:0].

3. LVDS interface Display signal: DCLK P/N; RX[3:0] P/N.

5.2 Recommend power on reset timing

Setting GRB pin to "L" (hardware reset) can initialize internal function. Initialized by GRB pin is essential before operating. There are two suggestions for hardware reset connection.

(1) The GRB pin with external RC circuit.

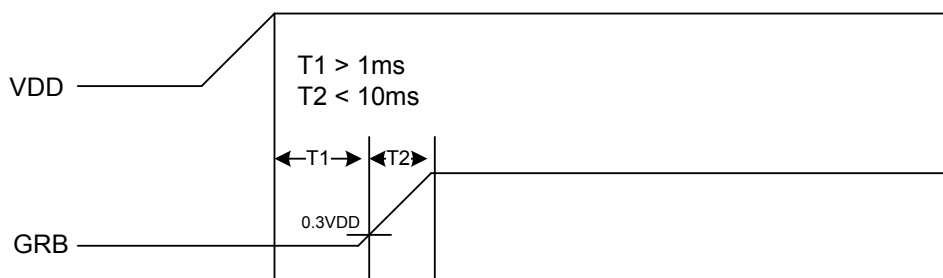
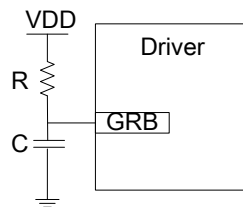



5.3 Timing of RGB Interface

DCLK Neagtive Polarity (DCLKPOL="H")

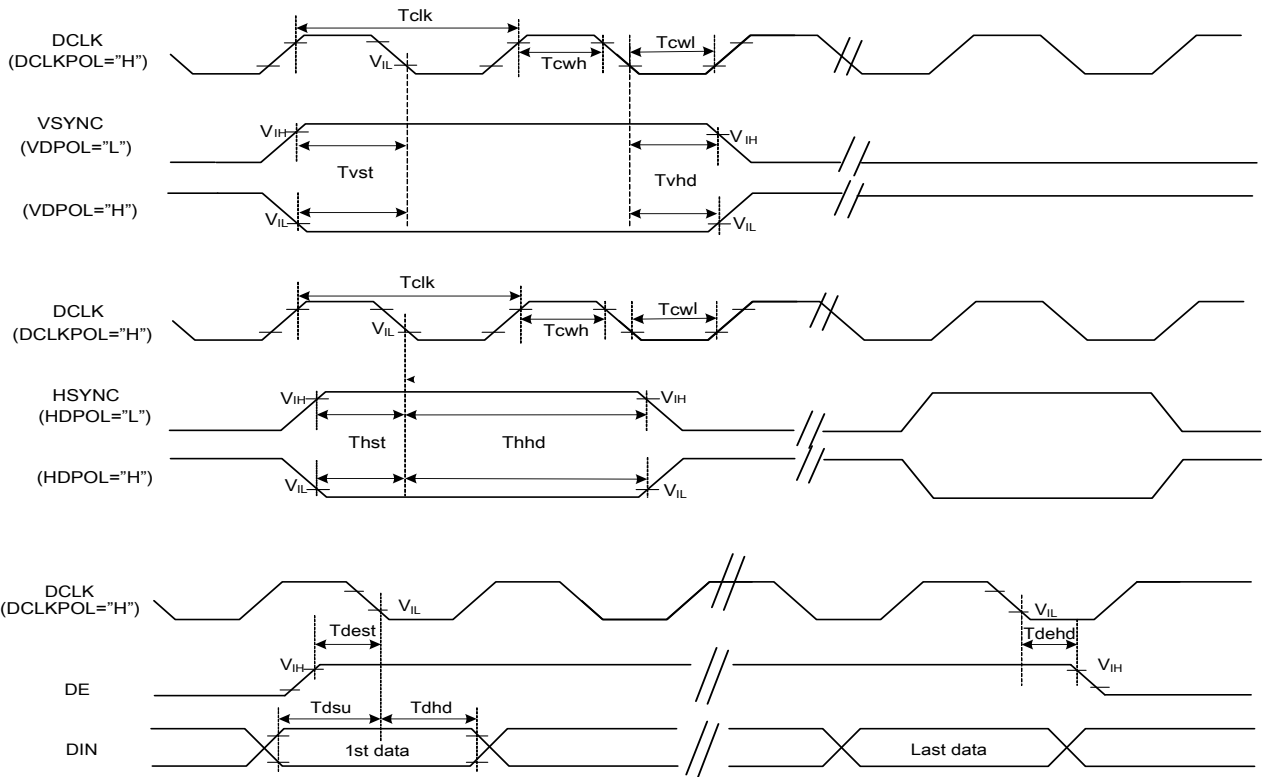

DCLK Positive Polarity (DCLKPOL="L")

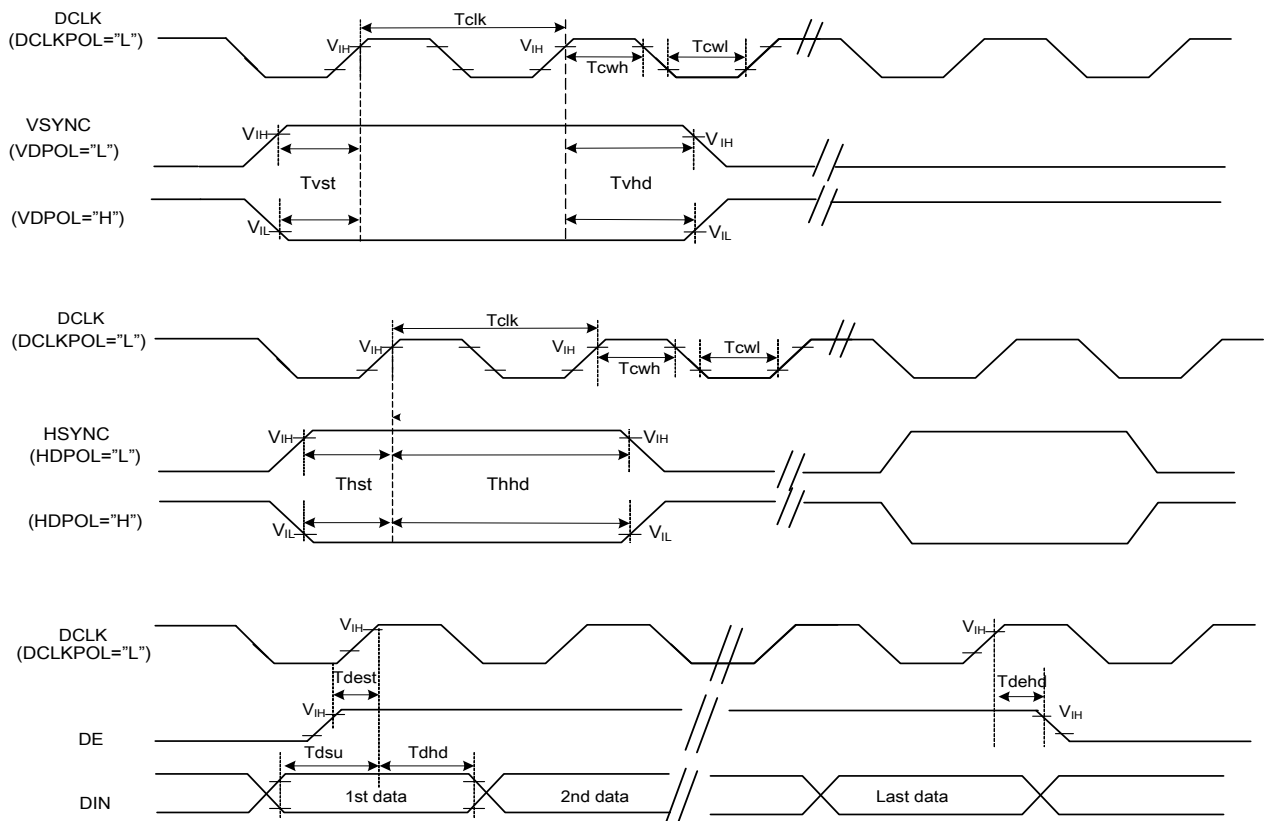



DC Electrical Characteristics (PVDD=VDD=VDDI= 3.3V, AGND= 0V, TA=25°C, Bare Chip)

Item	Symbol	Min.	Typ.	Max.	Unit	Conditions
CLK Pulse Duty	T _{cw}	40	50	60	%	
VSYNC Setup Time	T _{vst}	10	-	-	ns	
VSYNC Hold Time	T _{vhd}	10	-	-	ns	
HSYNC Setup Time	T _{hst}	10	-	-	ns	
HSYNC Hold Time	T _{hhd}	10	-	-	ns	
Data Setup Time	T _{dsu}	10	-	-	ns	
Data Hold Time	T _{dhd}	10	-	-	ns	
DE Setup Time	T _{dest}	10	-	-	ns	
DE Hold Time	T _{dehd}	10	- <td -	ns		

5.4 Lane VESA Data Format Color Bit Map

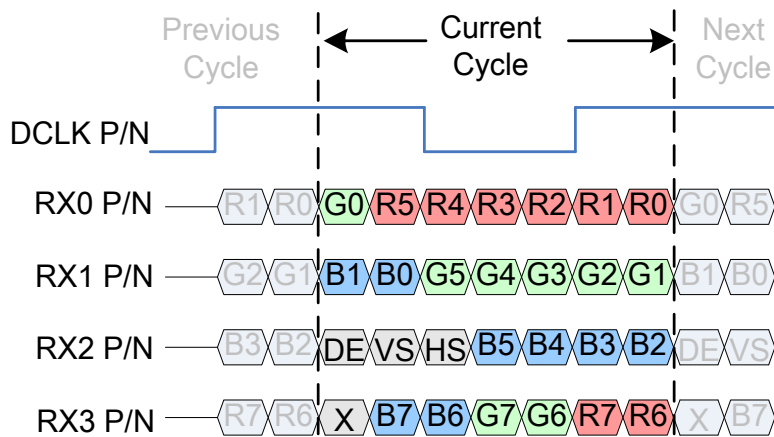



5.5 LVDS Input Timing Table

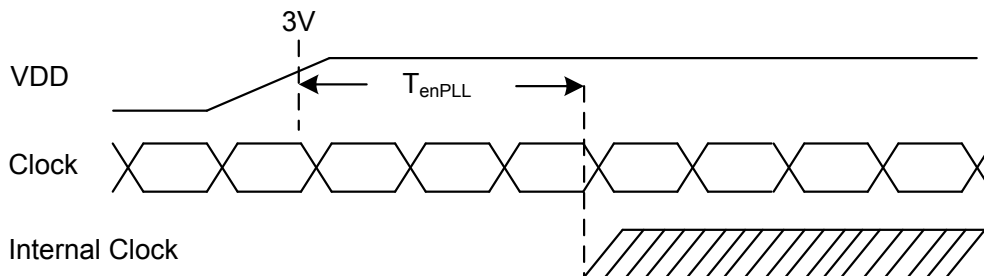
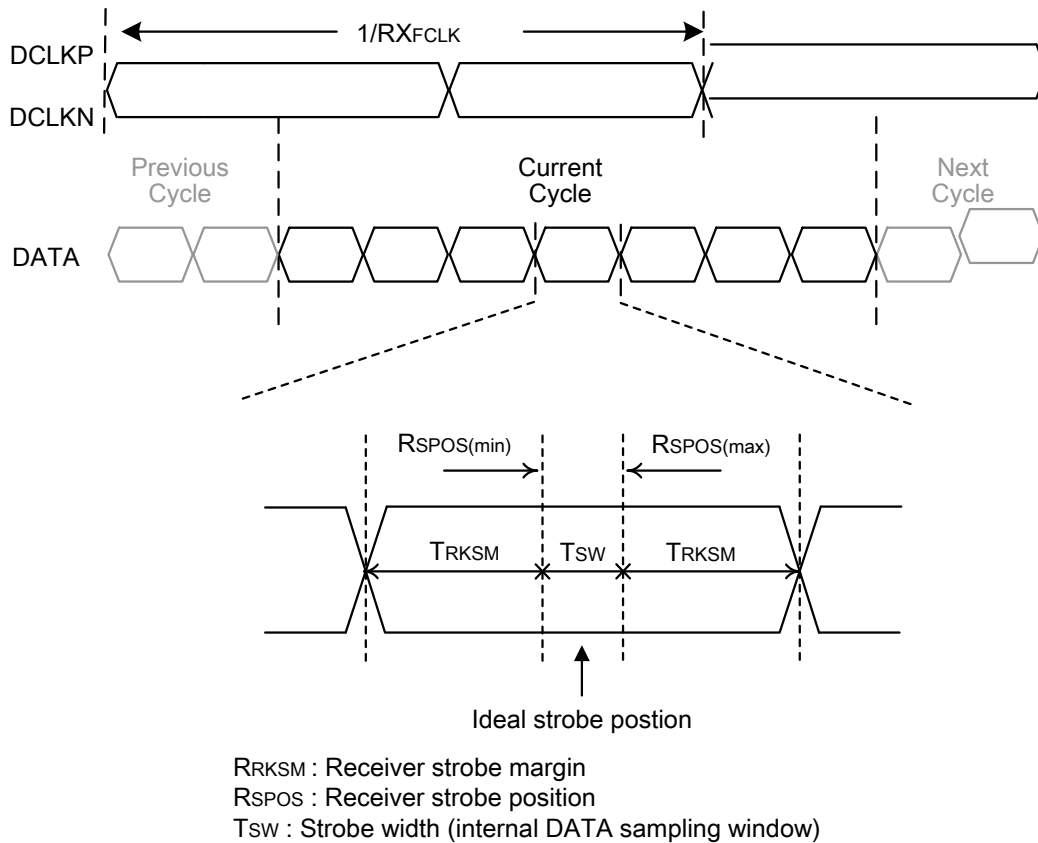

LVDS Input Timing (PVDD=VDD=VDDI= 3.3V, AGND= 0V, TA=25°C)

Item	Symbol	Min.	Typ.	Max.	Unit	Conditions
Clock Frequency	RXFCLK	23	25	30	MHz	
Input Data Skew Margin	TRSKM	400	-	-	ps	
Clock High Time	TLVCH	4/(7 x RXFCLK)			ns	
Clock Low Time	TLVCL	3/(7 x RXFCLK)			ns	
PLL Wake-up Time	TenPLL	-	-	150	us	
LVDS Spread Spectrum Clocking (SSC) Tolerance of LVDS Receiver						
Modulation Frequency	SSCMF	-	-	100	KHz	
Modulation Rate	SSCMR	-	-	+/-3	%	



6. Optical Characteristic

6.1 Optical Specification

Item	Symbol	Condition	Min.	Typ.	Max.	Unit	Note	
Transmittance (with Polarizer)	T (%)		—	(4.8)	—	%	Measuring with normal polarizer , Reference Only Base on Vop=5.1V	
Transmittance (without Polarizer)	T (%)		—	(16.2)	—	%		
Contrast Ratio	CR		(800)	(1000)	—	—	(1)(2)	
Luminance	L _v	Θ=0 Normal viewing angle	900	1000	—	cd/m ²		
Response Time	T _{R+T_F}		—	30	40	msec	(1)(3)	
Color Gamut	(%)		45	50	—	%	C-light	
Color Chromaticity (CIE1931)	White		W _x	—	(0.320)	—	—	(1)(4) CF glass C-light
			W _y	—	(0.345)	—	—	
	Red		R _x	—	(0.629)	—	—	
		R _y	—	(0.326)	—	—		
	Green	G _x	—	(0.337)	—	—		
		G _y	—	(0.546)	—	—		
Blue	B _x	—	(0.136)	—	—			
	B _y	—	(0.143)	—	—			
Viewing Angle	Hor.	Θ _L	CR>10	70	80	—	(1)(4) Measuring with normal polarizer , Reference Only	
		Θ _R		70	80	—		
	Ver.	Θ _U		70	80	—		
		Θ _D		70	80	—		
Optima View Direction	Free						(5)	



6.2 Measuring Condition

- Measuring surrounding : dark room
- Ambient temperature : $25\pm 2^{\circ}\text{C}$
- 15min. warm-up time.

6.3 Measuring Equipment

- FPM520 of Westar Display technologies, INC., which utilized SR-3 for Chromaticity and BM-5A for other optical characteristics.

Note (1) Definition of Viewing Angle:

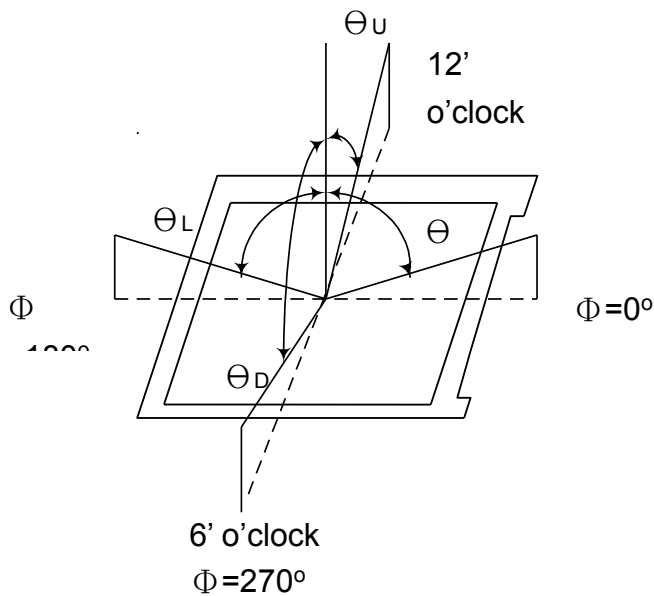

Note (2) Definition of Contrast Ratio (CR) :
measured at the center point of panel

$$\text{CR} = \frac{\text{Luminance with all pixels white}}{\text{Luminance with all pixels black}}$$



Note (3) Definition of Response Time : Sum of T_R and T_F

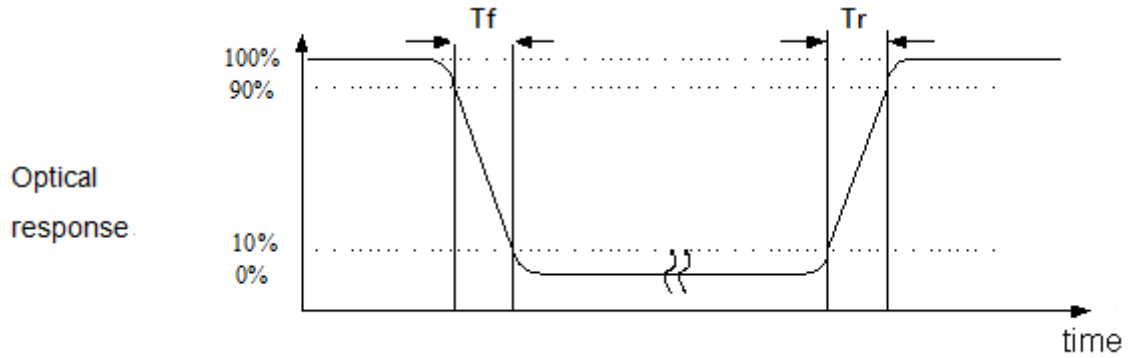

Note (4) Definition of optical measurement setup

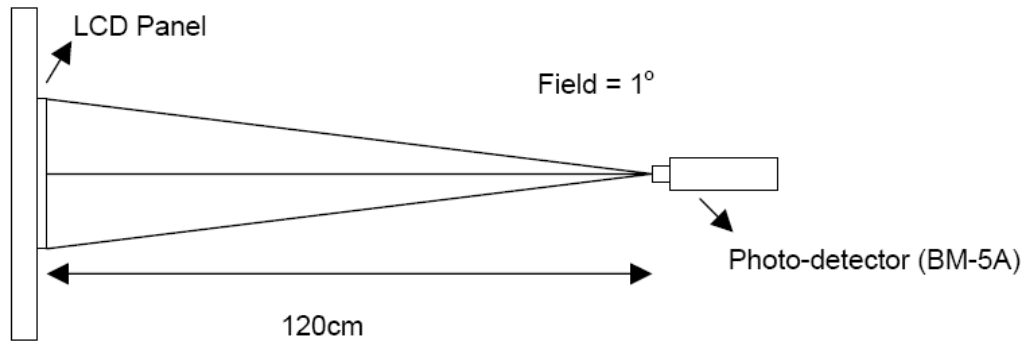



7. Environmental / Reliability Tests

No	Test Item	Test Condition	STANDARD
1	High Temperature Storage	+90°C / 96Hours	1. Functional test is OK. Missing Segment, short, unclear segment, on-display, display abnormally and liquid crystal leak are un-allowed. 2. No low temperature bubbles, end seal loose and fall, frame rainbow.
2	Low Temperature Storage	-40°C / 96Hours	
3	High Temperature Operating	+85°C / 96Hours	
4	Low Temperature Operating	-30°C / 96Hours	
5	Thermal and cold shock	-30°C ⇄ +85°C x 10cycles (30min) (5min) (30min)	
6	Operate at High Temperature and Humidity	60°C x 90%RH / 24H	
7	Vibration Test	Frequency: 10Hz~55Hz~10Hz Amplitude:1.5mm, 2 hours for each direction of X, Y, Z	1. Function test is OK. 2. No glass crack, chipped glass, end seal loose and fall, epoxy frame crack and so on. 3. No structure loose and fall.
8	Dropping test	Drop to the ground from 1m height, 1 corner, 3 edges, 6 surfaces.	
9	ESD test	Contact: ±6KV Air: ±10KV 150PF/330Ω, 5Points/panel, 5times	The test results shall be subject to the whole machine test.

NOTE:

1. The reliability items will be fully performed in new sample qualification,
2. The reliability status will be tested as monitor during mass production. Individual reliability test shall be performed by lot, Moreover, the individual reliability item shall be decided according to reliability plan.
3. All samples are inspected after keeping in the room with normal temperature and humidity for 2 hours or above.
4. Vibration test: It is not necessary to test for those products without assembly frame, backlight, PCB and so on.
5. Dropping test: It is necessary for affirming new package.
6. For the high temperature and high humidity test, pure water of over 10 MΩ.cm should be used.
7. Each test item applies for test LCM only once. Then tested LCM cannot be used again in any other test item.
8. The quantity of LCM examination for each test item is 5pcs to 10pcs.



8. Mechanical Drawing

由 Autodesk 教育版产品制作

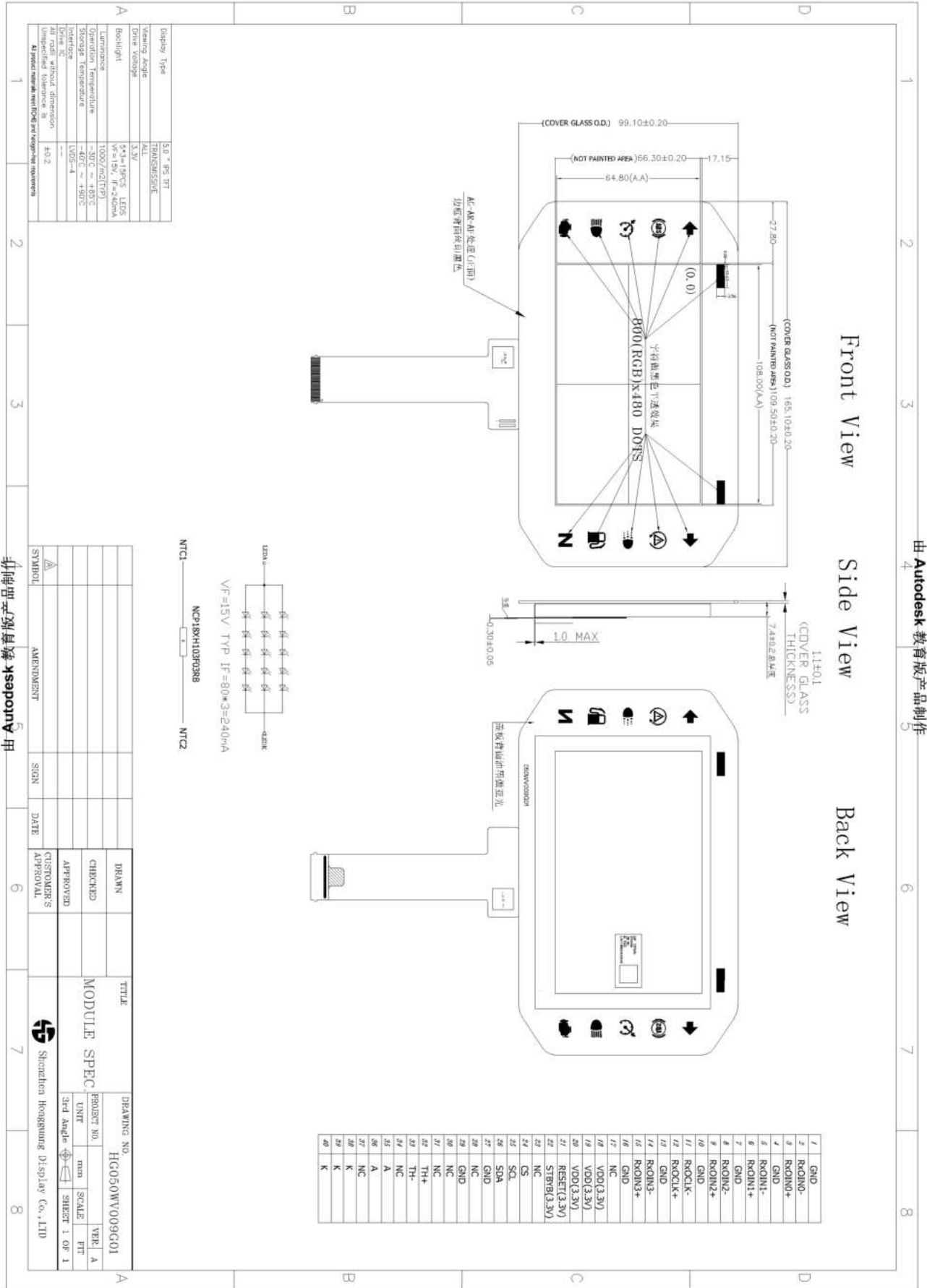



9. INSPECTION STANDARDS

9.1 AQL Sampling inspection standard

使用 GB/T 2828-2003 一般 II 水平, 采用正常检查一次抽样方式; 具体抽检方式参照《成品检验管理程序》、《抽样管理规范》

缺陷区分	AQL 允收水准
严重缺陷	0 收 1 退
重缺	0.4
轻缺	1.0

9.2 Inspect the condition

9.2.1 在 20—40W 日光灯的照明条件下, 样品离检查者眼睛约 30cm 处进行检查。检验方向以垂直线前后左右 45° (以时钟 3 点、6 点、9 点、12 点)

9.2.2 检验者视力需达到标准视力 1.0 以上。

9.2.3 检验者需戴静电手环、两手八个手指套。

9.2.4 外观检验者以目视检查或以菲林对比卡比对。

9.2.5 电性测试使用电测测架, 主板, 电源线及单片机。

9.2.6 若标准与规格书不符时, 以产品发行之规格书特殊检验规格、工程变更为准

9.2.7 辉色度检测请参照样品, 检测方法依照辉色度检验标准。

9.2.8 电测检验环境: 照度为 200LUX 以下, 外观检验环境: 照度为 600LUX-1000LUX, 检验时间: 1 秒-3 秒。

9.2.9 检验工具: 电测测架, 主板, 电源线及单片机, 菲林对比卡, 游标卡尺, 放大镜, 实体显微镜 (必要时) 等等。

9.3 Judgment criterion

小尺寸点、线判定标准: (6.2 寸以内)

1	点状缺陷 (磨伤、异物、针孔、凹痕、缺膜、气泡、白点、彩点、脏点)		判定 (A /B/C 区)	$D \leq 0.10$, 忽略不计, 但密集型不允许	MI	OK
				$0.1 < D \leq 0.15$, $ds \geq 10$		$N \leq 2$
				$0.15 < D \leq 0.2$, $ds \geq 10$		$N \leq 1$
				LCD 亮点: $0.15 < D$		$N \leq 1$
				$D > 0.2$		NG
			判定 (D 区)	同背面丝印油墨区杂质判定标准		
				注: 1) D 区的点状缺陷需在不影响 CTP 功能、客户组装及整机的外观的情况下, 判定 OK	MI	
2	线状缺陷 (磨伤、无感划伤、毛屑、纤维等)		判定 (A /B/C 区)	$W \leq 0.03mm$, $L \leq 3mm$, $ds \geq 10$	MI	$N \leq 2$
				$0.03mm < W \leq 0.05mm$, $L \leq 3mm$, $ds \geq 10$		$N \leq 1$
				$W > 0.05mm$ 或 $L > 3mm$		NG



中尺寸点、线判定标准：（6.2~8 寸以内）

1	点状缺陷 (磨伤、异物、针孔、凹痕、缺膜、气泡、白点、彩点、脏点)		判定(A/B/C区)	$D \leq 0.10$, 忽略不计, 但密集型不允许	MI	OK
				$0.15 < D \leq 0.25, ds \geq 10$ $0.25 < D \leq 3, ds \geq 10$ LCD亮点: $0.2 < D$ $D > 0.3$		N ≤ 2
			判定(D区)	同背面丝印油墨区杂质判定标准		N ≤ 1
				注: 1) D区的点状缺陷需在不影响CTP功能、客户组装及整机的外观的情况下, 判定OK	MI	NG
2	线状缺陷 (磨伤、无感划伤、毛屑、纤维等)		判定(A/B/C区)	$W \leq 0.03mm, L \leq 3mm, ds \geq 10$	MI	N ≤ 2
				$0.03mm < W \leq 0.05mm, L \leq 3mm, ds \geq 10$		N ≤ 1
				$W > 0.05mm$ 或 $L > 3mm$		NG

大尺寸点、线判定标准：（8.1~13.3 寸以内）

1	点状缺陷 (磨伤、异物、针孔、凹痕、缺膜、气泡、白点、彩点、脏点)		判定(A/B/C区)	$D \leq 0.1$, 忽略不计, 但密集型不允许	MI	OK
				$0.15 < D \leq 0.3, ds \geq 10$ $0.3 < D \leq 0.35, ds \geq 10$ LCD亮点: $0.25 < D$ $D > 0.35$		N ≤ 2
			判定(D区)	同背面丝印油墨区杂质判定标准		N ≤ 1
				注: 1) D区的点状缺陷需在不影响CTP功能、客户组装及整机的外观的情况下, 判定OK	MI	NG
2	线状缺陷 (磨伤、无感划伤、毛屑、纤维等)		判定(A/B/C区)	$W \leq 0.05mm, L \leq 5mm, ds \geq 10$	MI	N ≤ 2
				$0.05mm < W \leq 0.07mm, L \leq 5mm, ds \geq 10$		N ≤ 1
				$W > 0.07mm$ 或 $L > 5mm$		NG



10. Packing

