



SPECIFICATION FOR TFT LCD MODULE

CUSTOMER : _____

CUSTOMER MODULE : _____

HL MODEL : HG101WU013

Preliminary Specification

Final Specification

Customer Confirmation column:

Approved by : _____ Dept. : _____ Data : _____

Please return one of the copies of the specification with your signature to us within two weeks after you receive this document. If it is not returned, we will assume that you agree to the entire contents of this specification document.

Designed by	Checked by	Approved by



Project change resume information

Version	DATE	DESCRIPTION	CHANGED BY



CONTENTS

1. Features & Mechanical Specifications.....	3
2. Dimensional Outline.....	5
3. Pin Description.....	错误! 未定义书签。
4. Absolute Maximum Ratings.....	7
5. Electrical Characteristics.....	7
6. Backlight Characteristics.....	7
7. Electro-Optical Characteristics.....	8
8. MIPI ELECTRICAL CHARACTERISTICS.....	13
9. Quality Specifications.....	15
10. Reliability of LCM.....	17



1. Features & Mechanical Specifications

Item	Contents	Unit
	LCD	
LCD Type	TFT / Transmissive	--
Size	10.1	
Viewing direction	Full view	--
Backlight	White LED x 32	--
Interface	4 Lanes MIPI Interface	--
Outline Dimension	143.0(W) × 228.6(H) × 2.6(T)	mm
Glass area (W×H×T)	140.4× 225.35 × 0.5	mm
Active area (W×H)	135.36× 216.58	mm
Number of Dots	1200(RGB) × 1920	--
Operating Temperature	-10 ~ +50	°C
Storage temperature	-20 ~ +60	°C
Polarizer	Top: IPS film	--
	Bottom: IPS film	



2. Dimensional Outline

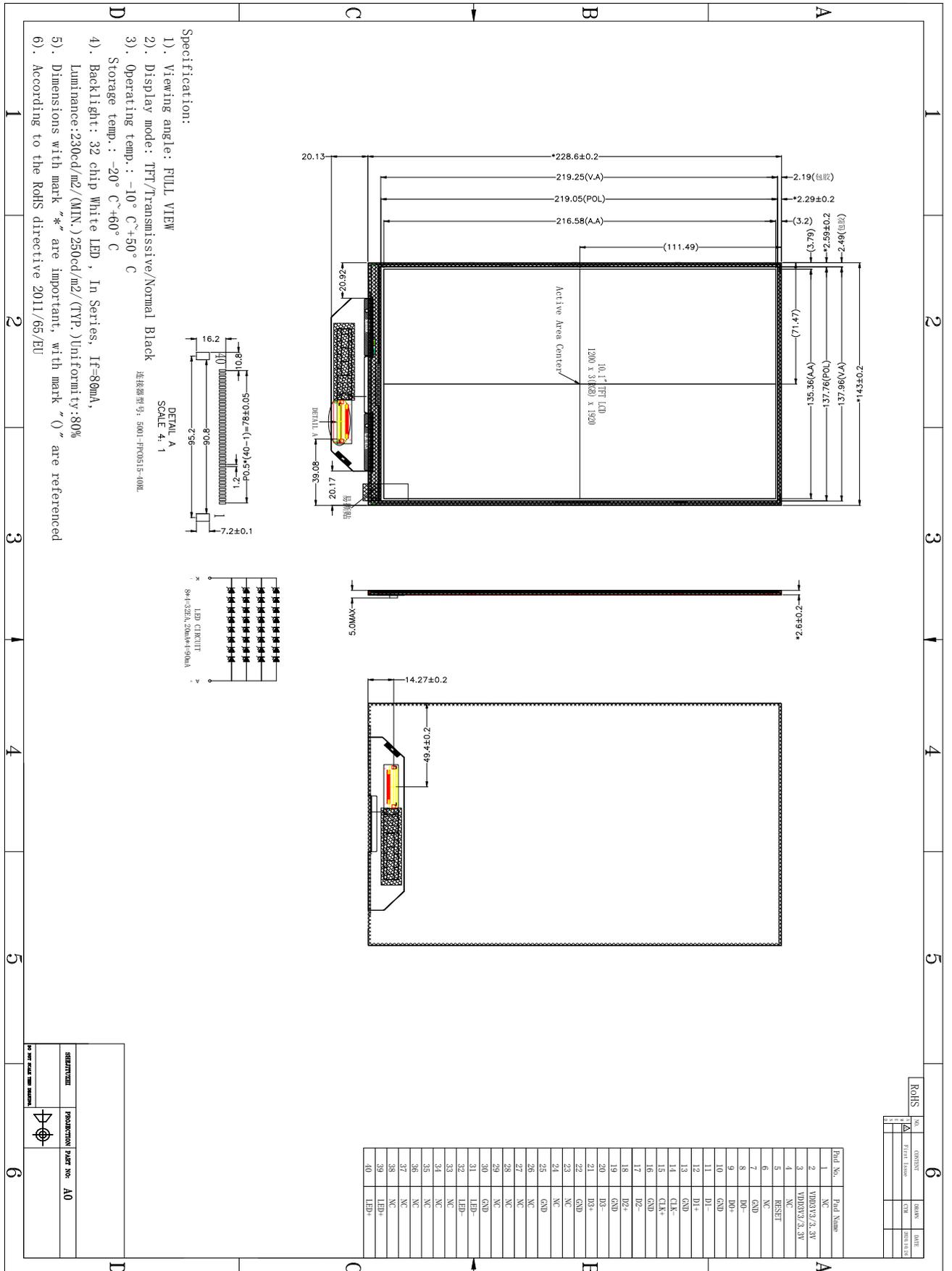



3. Pin Description

PIN No.	SYMBOL	Function
1	NC	No connection
2-3	VDD3V3	3.3V input
4	NC	No connection
5	RESET	Device reset signal 3.3V
6	NC	No connection
7	GND	Ground
8	MIPI_D0-	MIPI differential data0 input(Negative)
9	MIPI_D0+	MIPI differential data0 input(Positive)
10	GND	Ground
11	MIPI_D1-	MIPI differential data1 input(Negative)
12	MIPI_D1+	MIPI differential data1 input(Positive)
13	GND	Ground
14	MIPI_CLK-	MIPI differential clock input(Negative)
15	MIPI_CLK+	MIPI differential clock input(Positive)
16	GND	Ground
17	MIPI_D2-	MIPI differential data2input(Negative)
18	MIPI_D2+	MIPI differential data2 input(Positive)
19	GND	Ground
20	MIPI_D3-	MIPI differential data3 input(Negative)
21	MIPI_D3+	MIPI differential data3 input(Positive)
22	GND	Ground
23	NC	No connection
24	NC	No connection
25	GND	Ground
26	NC	No connection
27	NC	No connection
28	NC	No connection
29	NC	No connection
30	GND	Ground
31-32	LEDK	Cathode for light bar
33	NC	No connection
34	NC	No connection
35	NC	No connection
36	NC	No connection
37	NC	No connection
38	NC	No connection
39-40	LEDA	Anode for light bar



4. Absolute Maximum Ratings

Item	Symbol	Rating	Unit
Digital Supply Voltage	VDD	-0.3 to +4.0	V
Operating Temperature range	TOP	-10 to +50	°C
Storage Temperature range	TST	-20 to +60	°C

5. Electrical Characteristics

DC Characteristics

Item	Symbol	Min.	Type.	Max.	Unit
Digital Power Supply Voltage	VDD/IOVDD	3.0	3.3	3.6	V
	IDD	142 (3.6V)	145 (3.3V)	165 (3.0V)	ma

6. Backlight Characteristics

(White LED × 8 in series) × 4 in Parallel

(Ta = 25°C)

Item	Symbol	Condition	Min	Typ	Max	Unit
Forward Voltage	VF	IF=80mA	22.4	--	26.4	V
Uniformity	△Bp	-	80	-	-	%
LCM Luminance	Lv	IF=80mA	230	250	-	cd/m ²



7. Electro-Optical Characteristics

The relative measurement methods of optical characteristics are shown as below.

The following items should be measured under the test conditions described in

7.1

Item	Symbol	Condition	Value			Unit	Note	
			Min	Typ	Max			
Transmittance	T		4.5	5.23		%		
Uniformity	ΔBp		75	80		%	Note 6	
Viewing Angle	Left	θL	$Cr \geq 10$	75	80	deg	Note1	
	Right	θR		75	80			
	Top	ψT		75	80			
	Bottom	ψB		75	80			
Contrast Ratio	Cr		800	1000			Note 4	
Response Time	Tr+Tf	$\theta = 0$	--	25	--	ms	Note 3	
	Tgray	$= 0$		--		ms		
Color Coordinate of CIE1931	Red	X	$\theta = 0$ $= 0$	--	--	--	+/-0.05	Note 2.5.6
		y		--	--	--		
	Green	X		--	--	--		
		y		--	--	--		
	Blue	X		--	--	--		
		y		--	--	--		
	White	X		--	--	--		
		y		--	--	--		
NTSC			45	60		%		



Note 1: Definition of viewing angle range

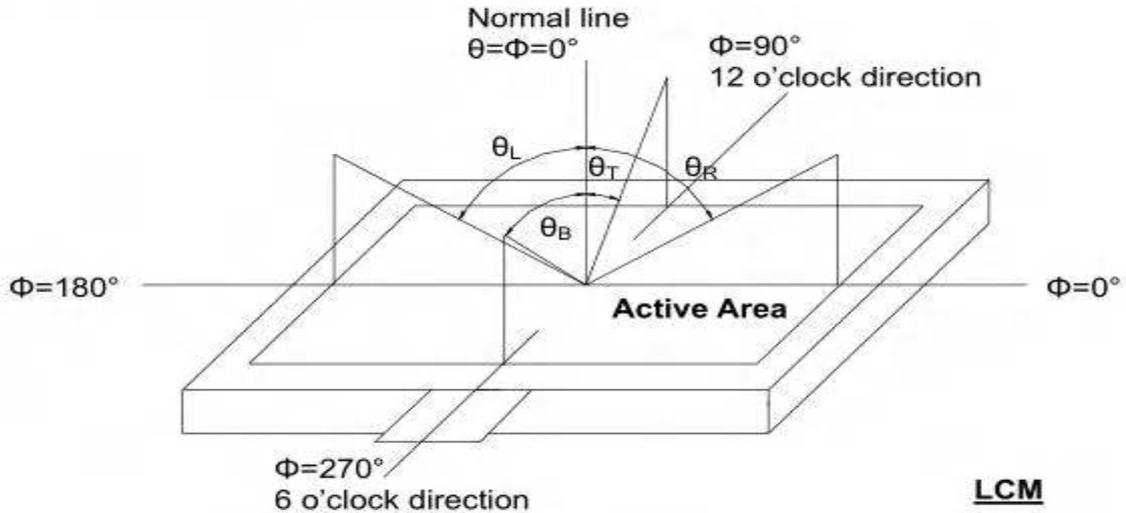
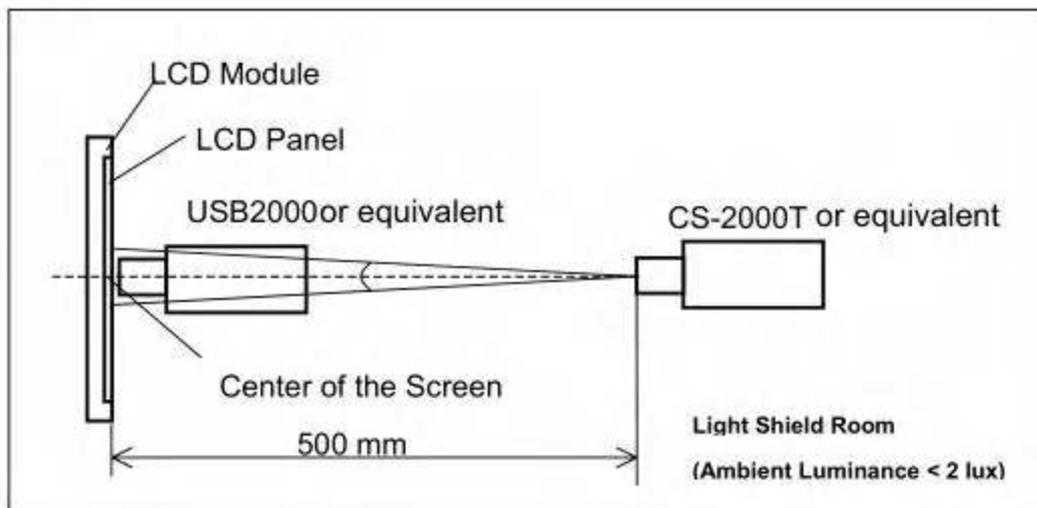

Fig. 4-1 Definition of viewing angle

Note 2: Definition of optical measurement system.

The optical characteristics should be measured in dark room. After 30 minutes operation, the optical properties are measured at the center point of the LCD screen. (Viewing angle is measured by ELDIM-EZ contrast/Height :1.2mm, Response time is measured by Photo detector TOPCON BM-7, other items are measured by BM-5A/ Field of view: 1° /Height: 500mm.)



Note 3: Definition of Response time

The response time is defined as the LCD optical switching time interval between "White" state and "Black" state. Rise time (T_{ON}) is the time between photo detector output intensity changed from 90% to 10%. And fall time (T_{OFF}) is the time between photo detector output intensity changed from 10% to 90%.

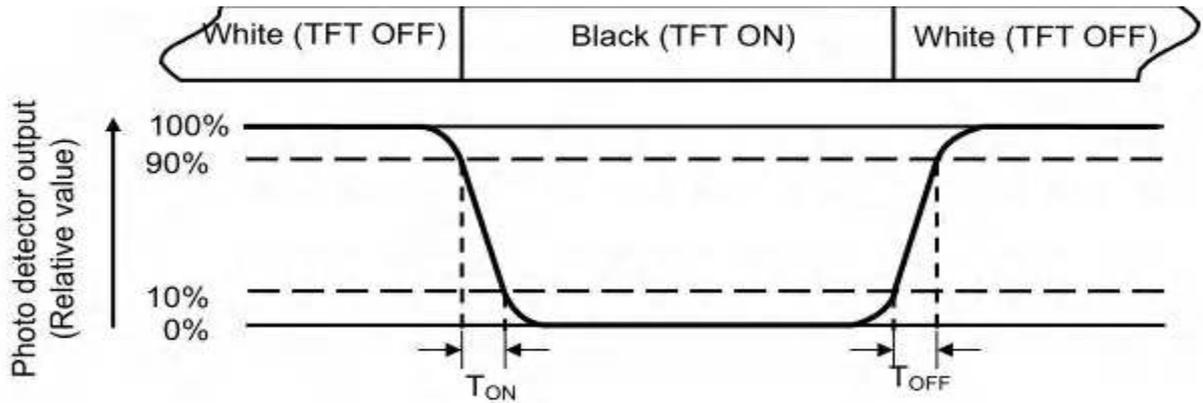

Fig. 4-3 Definition of response time

Note 4: Definition of contrast ratio

$$\text{Contrast ratio (CR)} = \frac{\text{Luminance measured when LCD on the "White" state}}{\text{Luminance measured when LCD on the "Black" state}}$$

Note 5: Definition of color chromaticity (CIE1931)

Color coordinates measured at center point of LCD.

Note 6: All input terminals LCD panel must be ground while measuring the center area of the panel.

Note 7: Definition of Luminance Uniformity

Active area is divided into 9 measuring areas (Refer to Fig. 4-4).Every measuring point is placed at the center of each measuring area.

$$\text{Luminance Uniformity (Yu)} = \frac{B_{min}}{B_{max}}$$

L-----Active area length W----- Active area width

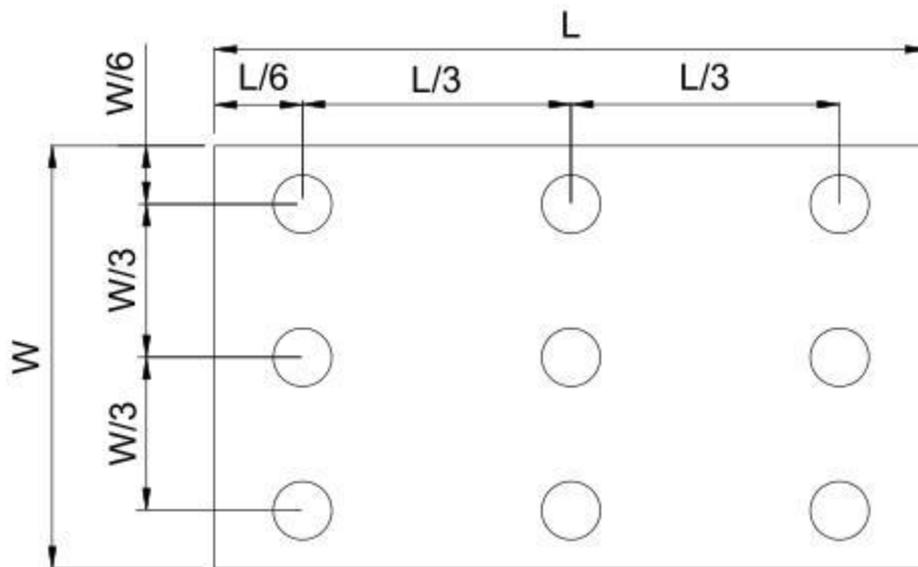

Fig. 4-4 Definition of measuring points

B_{max} : The measured maximum luminance of all measurement position.

B_{min} : The measured minimum luminance of all measurement position.



8.MIPI ELECTRICAL CHARACTERISTICS

8.1 DC Characteristics for DSI LP Mode

HS Receiver DC Specification

Parameter	Symbol	Rating			Unit	Note
		Min	Typ	Max		
Operation Voltage	VDD	1.5-10%	1.5	1.5+10%	mV	
Differential Input Voltage	VID	70	200	260	mV	
Common Mode Voltage	V _{CMRX(DC)}	70	-	330	mV	
Differential Input High Threshold Voltage	V _{TH}	-	-	70	mV	
Differential Input Low Threshold Voltage	V _{TL}	-70	-	-	mV	
Singled-ended input high voltage	V _{IHS}	-	-	460	mV	
Singled-ended input low voltage	V _{ILHS}	-40	-	-	mV	
Singled-ended threshold for HS termination enable	V _{TERM-EN}	-	-	450	mV	
Differential input impedance	Z _{ID}	80	100	125	ohm	
Pin leakage current	I _{LEAK}	-10	-	10	uA	
Common-mode interference beyond 450MHz	ΔV _{CMRX(HF)}	-	-	100	mV	
Common-mode interference 50MHz - 450MHz	ΔV _{CMRX(LF)}	-50	-	50	mV	
Common-mode termination	C _{CM}	-	-	60	pF	
Embedded Termination	R _T	90	100	110	ohm	2bits RT_SEL[1: 0] for termination resistor selection 00 → 200ohm 10 , 01 → 150ohm 11 → 100ohm (default) 1bit ERM _R _EN for termination resistor enable TERM _R _EN=0, termr disable R=(OPEN) TERM _R _EN=1, termr enable

Note:

- (1) Excluding possible additional RF interference of 100mV peak sine wave beyond 450MHz.
- (2) This table value includes a ground difference of 50mV between the transmitter and the receiver, the static common-mode level tolerance and variations below 450MHz.



8.2 Input Color Data Mapping

Color & Gray Scale		Input Data Signal																							
		Red Data								Green Data						Blue Data									
		R7	R6	R5	R4	R3	R2	R1	R0	G7	G6	G5	G4	G3	G2	G1	G0	B7	B6	B5	B4	B3	B2	B1	B0
Basic Colors	Black	0	0	0	0	0	0	0	0	0	0	0	0	0	0	0	0	0	0	0	0	0	0	0	0
	Blue	0	0	0	0	0	0	0	0	0	0	0	0	0	0	0	0	1	1	1	1	1	1	1	1
	Green	0	0	0	0	0	0	0	0	1	1	1	1	1	1	1	1	0	0	0	0	0	0	0	0
	Cyan	0	0	0	0	0	0	0	0	1	1	1	1	1	1	1	1	1	1	1	1	1	1	1	1
	Red	1	1	1	1	1	1	1	1	0	0	0	0	0	0	0	0	0	0	0	0	0	0	0	0
	Magenta	1	1	1	1	1	1	1	1	0	0	0	0	0	0	0	0	1	1	1	1	1	1	1	1
	Yellow	1	1	1	1	1	1	1	1	1	1	1	1	1	1	1	1	0	0	0	0	0	0	0	0
	White	1	1	1	1	1	1	1	1	1	1	1	1	1	1	1	1	1	1	1	1	1	1	1	1
Gray Scale of Red	Black	0	0	0	0	0	0	0	0	0	0	0	0	0	0	0	0	0	0	0	0	0	0	0	
	▲	0	0	0	0	0	0	0	1	0	0	0	0	0	0	0	0	0	0	0	0	0	0	0	
	Darker	0	0	0	0	0	0	1	0	0	0	0	0	0	0	0	0	0	0	0	0	0	0	0	
	▲																								
	▼																								
	Brighter	1	1	1	1	1	1	0	1	0	0	0	0	0	0	0	0	0	0	0	0	0	0	0	
	▼	1	1	1	1	1	1	1	0	0	0	0	0	0	0	0	0	0	0	0	0	0	0	0	
	Red	1	1	1	1	1	1	1	1	0	0	0	0	0	0	0	0	0	0	0	0	0	0	0	0
Gray Scale of Green	Black	0	0	0	0	0	0	0	0	0	0	0	0	0	0	0	0	0	0	0	0	0	0	0	
	▲	0	0	0	0	0	0	0	0	0	0	0	0	0	0	0	1	0	0	0	0	0	0	0	
	Darker	0	0	0	0	0	0	0	0	0	0	0	0	0	0	1	0	0	0	0	0	0	0	0	
	▲																								
	▼																								
	Brighter	0	0	0	0	0	0	0	0	1	1	1	1	1	1	0	1	0	0	0	0	0	0	0	
	▼	0	0	0	0	0	0	0	0	1	1	1	1	1	1	1	0	0	0	0	0	0	0	0	
	Green	0	0	0	0	0	0	0	0	1	1	1	1	1	1	1	1	0	0	0	0	0	0	0	0
Gray Scale of Blue	Black	0	0	0	0	0	0	0	0	0	0	0	0	0	0	0	0	0	0	0	0	0	0	0	
	▲	0	0	0	0	0	0	0	0	0	0	0	0	0	0	0	0	0	0	0	0	0	0	1	
	Darker	0	0	0	0	0	0	0	0	0	0	0	0	0	0	0	0	0	0	0	0	0	0	1	
	▲																								
	▼																								
	Brighter	0	0	0	0	0	0	0	0	0	0	0	0	0	0	0	1	1	1	1	1	1	0	1	
	▼	0	0	0	0	0	0	0	0	0	0	0	0	0	0	0	1	1	1	1	1	1	1	0	
	Blue	0	0	0	0	0	0	0	0	0	0	0	0	0	0	0	1	1	1	1	1	1	1	1	
Gray Scale of White	Black	0	0	0	0	0	0	0	0	0	0	0	0	0	0	0	0	0	0	0	0	0	0	0	
	▲	0	0	0	0	0	0	1	0	0	0	0	0	0	0	1	0	0	0	0	0	0	0	1	
	Darker	0	0	0	0	0	0	1	0	0	0	0	0	0	1	0	0	0	0	0	0	0	1	0	
	▲																								
	▼																								
	Brighter	1	1	1	1	1	1	0	1	1	1	1	1	1	0	1	1	1	1	1	1	1	0	1	
	▼	1	1	1	1	1	1	1	0	1	1	1	1	1	1	0	1	1	1	1	1	1	1	0	
	White	1	1	1	1	1	1	1	1	1	1	1	1	1	1	1	1	1	1	1	1	1	1	1	



8.3AC Specification

HS Receiver AC Timing Characteristics

Parameter	Symbol	Rating			Unit	Note
		Min	Typ	Max		
Bandwidth per lane	-	-	-	1000	Mbps	Bandwidth selected by register 'speedup' Speedup=0 → Max=550Mbps Speedup=1 → Max=1000Mbps
Operation frequency	-	-	-	500	MHz	
UI instantaneous	U_{INST}	1	-	12.5	ns	1
Data to Clock Skew	T_{skew}	-0.15	-	0.15	U_{INST}	
Inter-lane static skew	$T_{skew-lane}$	-	-	$U_{INST}/50$	U_{INST}	
Data to Clock Setup Time	T_{SETUP}	0.25	-	-	U_{INST}	2
Data to Clock Hold Time	T_{HOLD}	0.25	-	-	U_{INST}	
Common-mode interference beyond 450MHz	$\Delta V_{CMRX(HF)}$	-	-	100	mV	4
Common-mode interference 50MHz- 450MHz	$\Delta V_{CMRX(LF)}$	-50	-	50	mV	3,6
Common-mode termination	C_{CM}	-	-	60	pF	5

Note:

- (1) Total silicon and package delay budget of $0.3 \cdot U_{INST}$
- (2) Total setup and hold window for receiver of $0.3 \cdot U_{INST}$
- (3) Excluding 'static' ground shift of 50mV
- (4) $\Delta V_{CMRX(HF)}$ is the peak amplitude of a sine wave superimposed on the receiver input
- (5) For higher bit rates a 14pF capacitor will be needed to meet the common-mode return loss specification.
- (6) Voltage difference compared to the DC average common-mode potential.

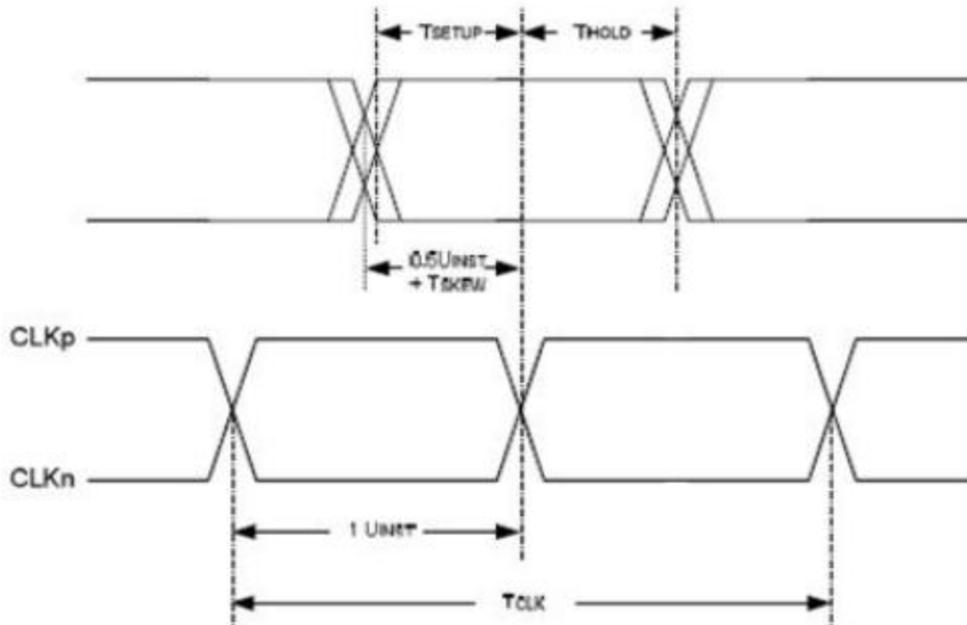



8.4 Interface timing Parameter

1200RGBx1920 (4 Data Lanes)

Parameter	Symbol	Min.	Typ.	Max.	Unit
MIPI data frequency	FDATA	955	999	1000	Mbps
Horizontal display area	THD	1200			pixel
HS period time	TH	1275	1341	1342	pixel
HS pulse width	THPW	1	1	1	pixel
HS back porch	THBP	32	60	60	pixel
HS front porch	THFP	42	80	81	pixel
Vertical display area	TVD	1920			H
VS period time	TV	1981	1981	1982	H
VS pulse width	TVPW	1	1	1	H
VS back porch	TVBP	25			H
VS front porch	TVFP	35	35	36	H

8.5 Power Sequence

Power-On/Off Timing Sequence:

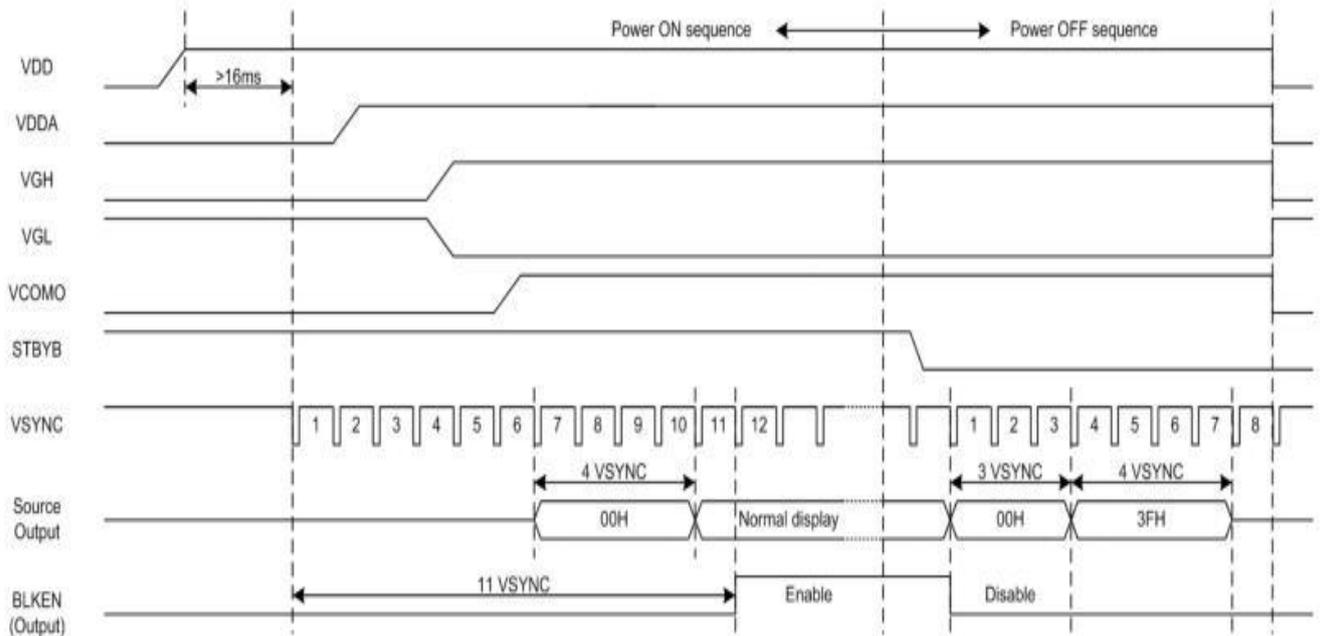



9. Quality Specifications

All The raw material are Rohs compllicant.

9. Standard of the product appearance test

9.1.1 通常在 $22\pm 3^{\circ}\text{C}$, $50\pm 10\%\text{RH}$ 的环境, 光强度 500Lux 下 (20W 日光灯, 40cm 距离左右) 检验员的眼睛与模块之间的距离为 $35\text{cm}\pm 5\text{cm}$, LCD下面用背光源来检查 (见图4)



图 4)

9.1.2 模块目视检验方向, 按图纸规定视角方向偏离 LCD 平面法线 45° ;

9.1.3 采用裸眼检查, 检验者需戴好防静电手环、防静电手套;

9.1.4 功能测试时, 产品在正常显示时用棉签或手指轻轻按压 FPC 邦定处、电子元件处、背 光焊接处, 检查是否存在不稳定现象。

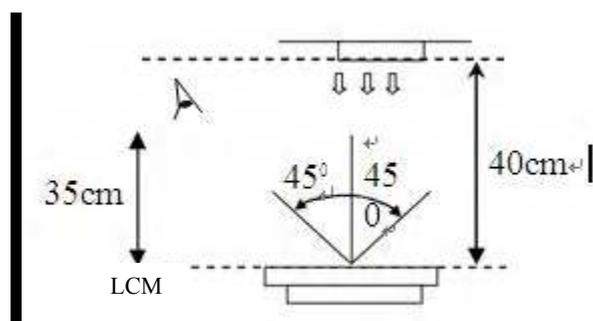
9.1.5; 相关IIS标准与双方协商确认;

9.2、包装

9.2.1 产品的内外包装方法参照图纸及设计要求来包装。

9.2.2 如客户有特殊的包装要求, 按客户的要求执行。

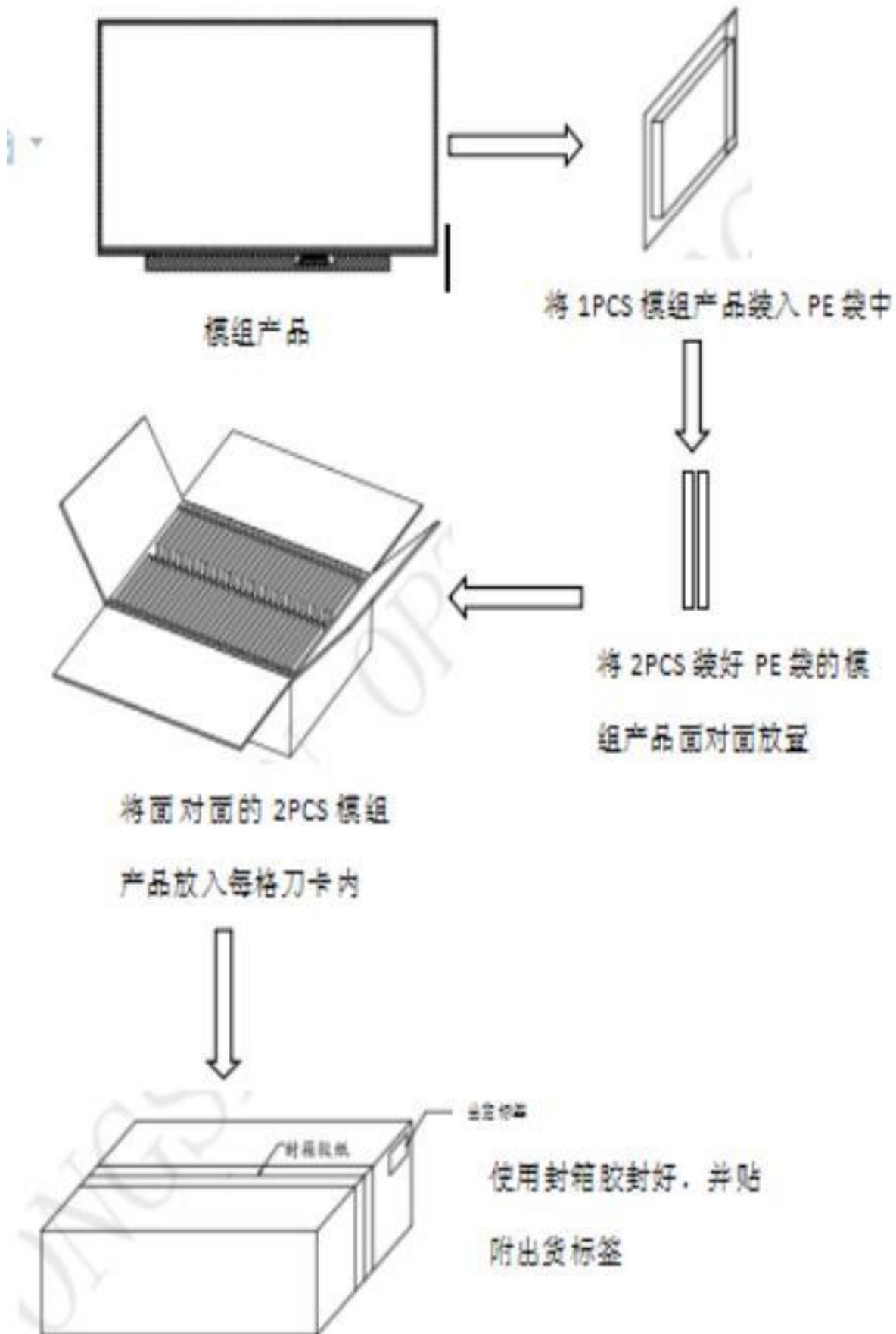



10. Reliability of LCM

Item	Condition	Time (hrs)	Assessment
High temp. Storage	60°C	48	No abnormalities in functions and appearance
High temp. Operating	50°C	48	
Low temp. Storage	-20°C	48	
Low temp. Operating	-10°C	48	
Humidity	50°C/80%RH	48	

Note: the above experimental conditions need to assemble the finished product prototype in the experiment;

Recovery time should be 24 hours minimum. Moreover, functions, performance and appearance shall be free from remarkable deterioration within 50,000 hours under ordinary operating and storage conditions room temperature ($23 \pm 2^{\circ}\text{C}$), normal humidity (below 45%~75% RH), and in the area not exposed to direct sun light.