



# SPECIFICATION FOR TFT LCD MODULE

CUSTOMER : \_\_\_\_\_

CUSTOMER MODULE : \_\_\_\_\_

HL MODEL :     HG101WX054    

Preliminary Specification

Final Specification

Customer Confirmation column:

Approved by : \_\_\_\_\_ Dept. : \_\_\_\_\_ Data : \_\_\_\_\_

Please return one of the copies of the specification with your signature to us within two weeks after you receive this document. If it is not returned, we will assume that you agree to the entire contents of this specification document.

Designed by	Checked by	Approved by



## REVISION STATUS

Version	Revise Date	Page	Content	Modified by
V1.0	2021.10.23	-	First Issued.	M



## TABLE OF CONTENTS

No.	CONTENTS	PAGE
	REVISION STATUS.....	2
	TABLE OF CONTENTS.....	3
1.	GENERAL DESCRIPTION.....	4
2.	MECHANICAL SPECIFICATION.....	5
3.	PIN DESCRIPTION.....	6
4.	ELECTRICAL CHARACTERISTICS.....	7
5.	OPTICAL CHARACTERISTICS.....	9
6.	RELIABILITY TEST ITEMS.....	11
7.	GENERAL PRECAUTION.....	12



## 1. GENERAL DESCRIPTION

### 1.1 DESCRIPTION

HG101WX054-V0 is a color active matrix thin film transistor (TFT) IPS liquid crystal display (LCD) that uses amorphous silicon TFT as a switching device. It is composed of a TFT LCD panel, Driver IC, FPC and Backlight, This TFT LCD has a 10.1-inch diagonally measured active display area with WSVGA resolution (800 vertical by 1280 horizontal pixel array).

### 1.2 FEATURES:

No.	Item	Specification	Unit
1	Panel Size	10.1"	inch
2	Number of Pixels	800×RGB (3) ×1280	pixels
3	Active Area	135.36(H)×216.576(V)	mm
4	Outline Dimension	143(W)×228.6(H)×2.6(D)	mm
5	Number of Colors	16.7M	-
6	Viewing Direction	ALL	-
7	Luminance (cd/m <sup>2</sup> )	350(TYP.)	nit
8	Interface	MIPI	-
9	Backlight	32-LEDs (White)	-
10	Operation Temperature	0-50	°C
11	Storage Temperature	-10-60	°C
12	Weight	TBD	g
13	推荐 Source IC	TBD	



## 2. MECHANICAL SPECIFICATION

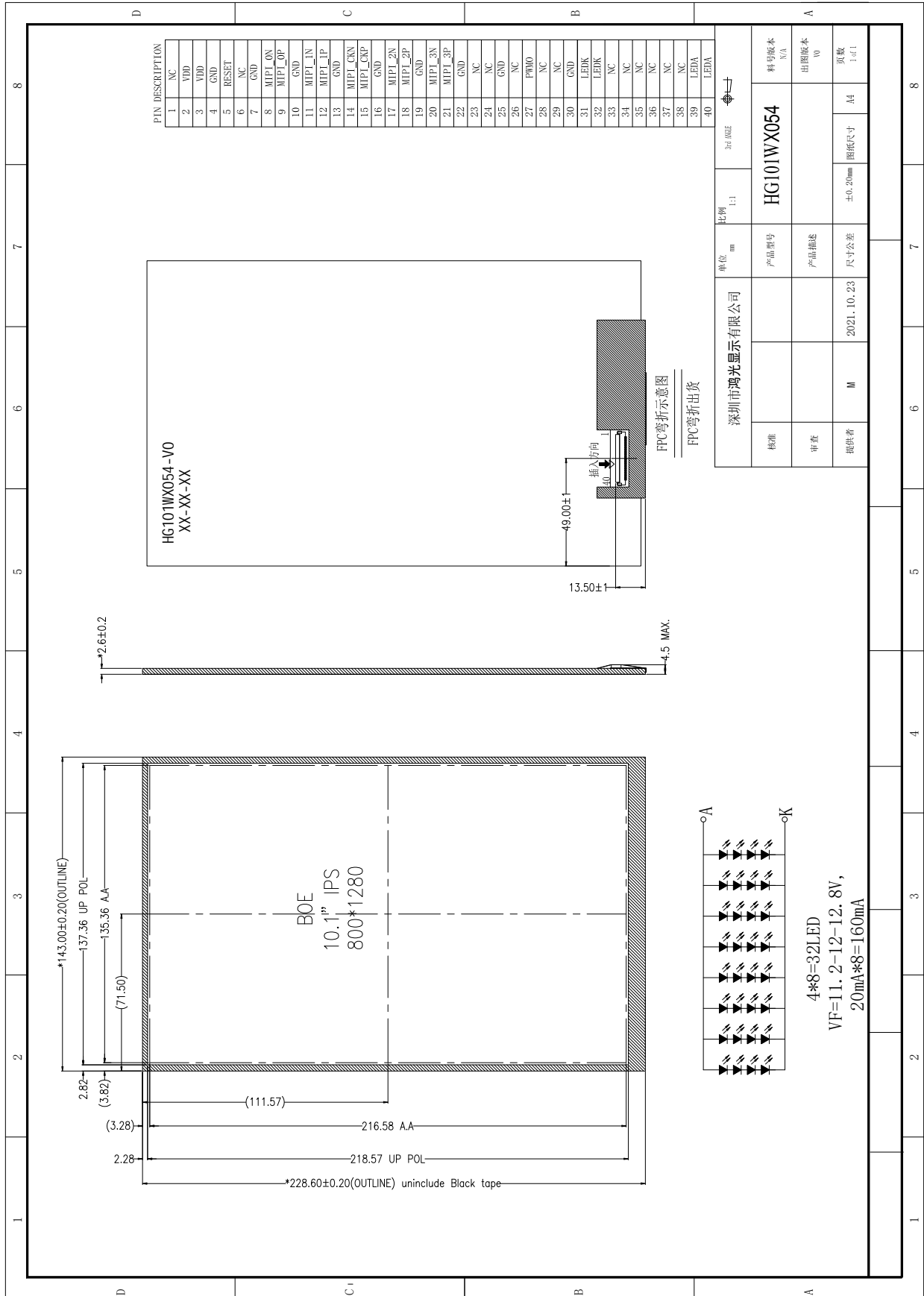



## 3. PIN DESCRIPTION

No.	Symbol	Function
1	NC	No connection
2	VDD	Power Voltage for digital circuit 3.3V
3	VDD	Power Voltage for digital circuit 3.3V
4	GND	Ground
5	RESET	Global reset signal 3.3V
6	NC	No connection
7	GND	Ground
8	MIPI_D0N	MIPI Negative data signal(-)
9	MIPI_D0P	MIPI Positive data signal(+)
10	GND	Ground
11	MIPI_D1N	MIPI Negative data signal(-)
12	MIPI_D1P	MIPI Positive data signal(+)
13	GND	Ground
14	MIPI_CKN	MIPI Negative clock signal(-)
15	MIPI_CKP	MIPI Positive clock signal(+)
16	GND	Ground
17	MIPI_D2N	MIPI Negative data signal(-)
18	MIPI_D2P	MIPI Positive data signal(+)
19	GND	Ground
20	MIPI_D3N	MIPI Negative data signal(-)
21	MIPI_D3P	MIPI Positive data signal(+)
22	GND	Ground
23	NC	No connection
24	NC	No connection
25	GND	Ground
26	NC	No connection
27	PWMO	PWM control signal for LED driver (CABC)
28	NC	No connection
29	NC	No connection
30	GND	Ground
31	LEDK	LED Cathode
32	LEDK	LED Cathode
33	NC	No connection



34	NC	No connection
35	NC	No connection
36	NC	No connection
37	NC	No connection
38	NC	No connection
39	LEDA	LED Anode
40	LEDA	LED Anode

## 4. Electrical Characteristics

### 4.1 TFT LCD MODULE

Parameter	Symbol	Min.	Typ.	Max.	Unit
power supply voltage	VDD		3.3	3.6	V
power supply ripple voltage	VRP			350	mV
power supply current	IDD	--	225	251	mA
Power consumption	PD	--	0.735	0.830	w

### 4.2 POWER ON/OFF SEQUENCE

To prevent the device damage from latch up, the power on/off sequence shown below must be followed.

Power on: VDD, GND → AVDD, AGND → V1 to V14

Power off: V1 to V14 → AVDD, AGND → VDD, GND

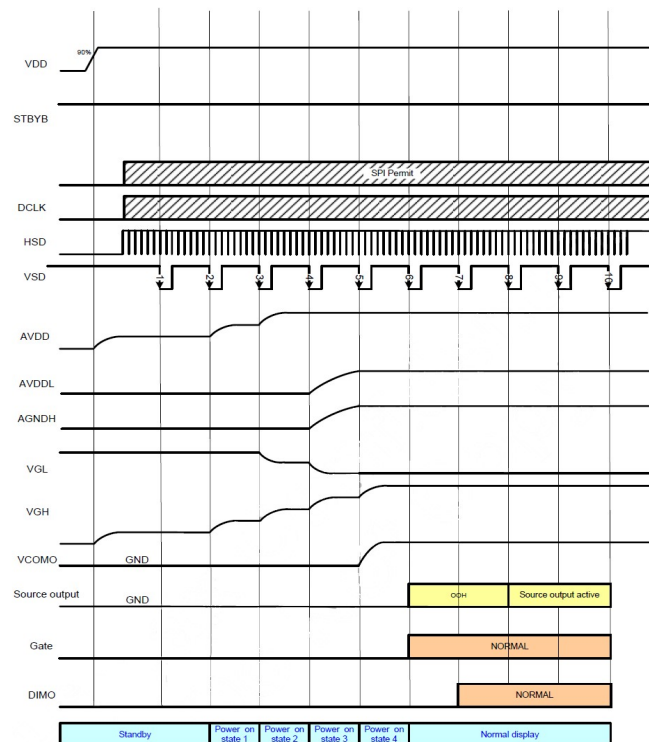



## Power on timing sequence

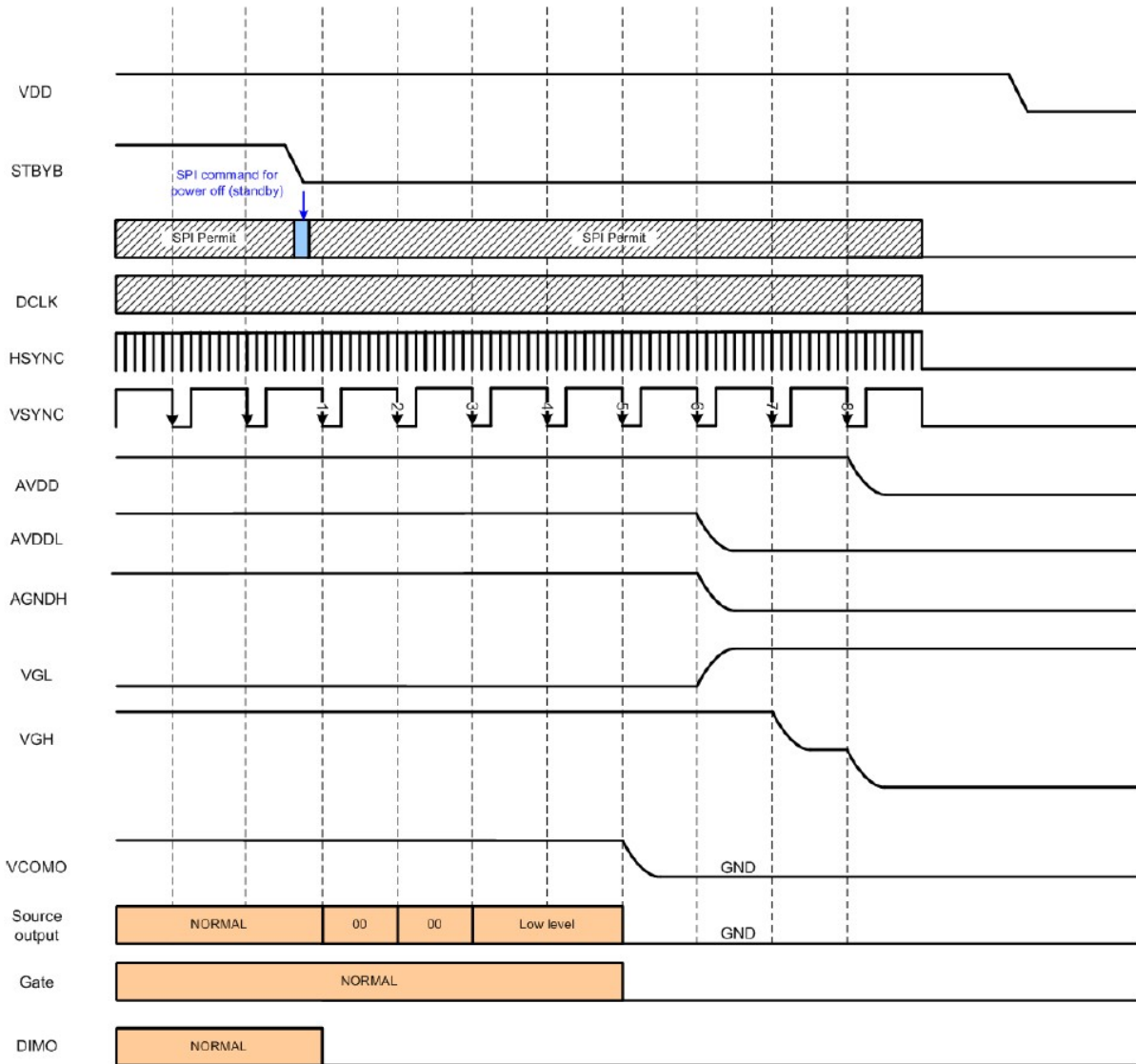

## Power off timing sequence

Note: Low level=3FH, when NBW=L (Normally white)

Low level=00H, when NBW=H (Normally black)

## 4.3 BACK LIGHT UNIT

Ta=25°C

Item	Symbol	Min.	Typ.	Max.	Unit	Remark
LED current	I <sub>LED</sub>		160		mA	32LEDS
Forward voltage	V <sub>F</sub>	11.2	12	12.8	V	I <sub>F</sub> =160mA 32LEDS
Reverse current	I <sub>R</sub>			50	μA	V <sub>R</sub> =10V, 1LED
Power dissipation	P <sub>d</sub>	2048			mW	32LEDS
Reverse Voltage	V <sub>R</sub>	10			V	1LED





## 5. OPTICAL CHARACTERISTICS

Item	Symbol	Min.	Typ.	Max.	Unit	Note
Contrast Ratio	CR	800	1000	-		Note1 Note3
Luminance	YL	-	350	-	cd/m <sup>2</sup>	Note1 Note5
Luminous tolerance	I IV-M point5	75			%	Note1 Note6
	IV-M point13	70				
Response Time	Rising + Falling	-	30	-	ms	Note1 Note4
Viewing Angle[degrees] K=Contrast Ratio>10	Horizontal	75	80		degree	Note1 Note2
	Vertical	75	80			
Color Chromaticity	Red	x	-	-	-	Note1
		y	-	-	-	
	Green	x	-	-	-	
		y	-	-	-	
	Blue	x	-	-	-	
		y	-	-	-	
White	x	-	-	-		
	y	-	-	-		

Note1: Measurement Setup

The LCD module should be stabilized at given temperature for 15 minutes to avoid abrupt temperature change during measuring. In order to stabilize the luminance, the measurement should be executed after lighting backlight for 15 minutes in a windless room.

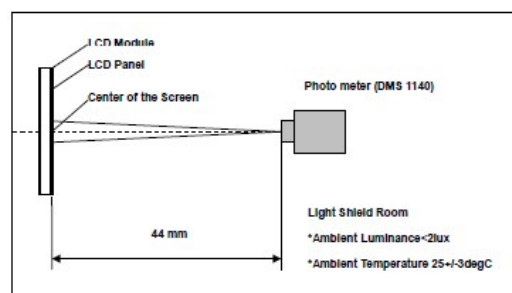



## Note2: Definition of Viewing Angle

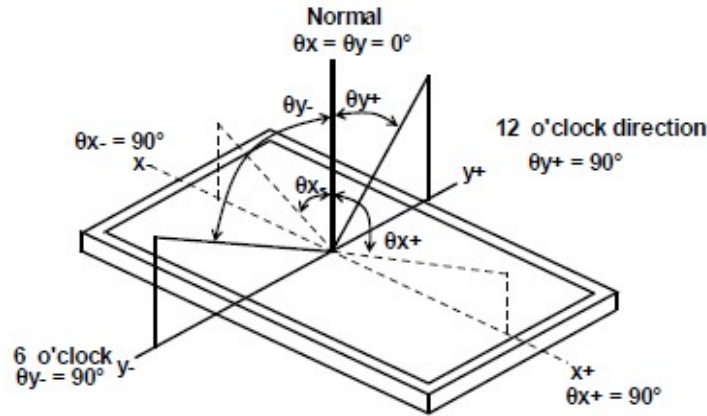

## Note3: Definition of Contrast Ratio (CR)

The contrast ratio can be calculated by the following expression

$$\text{Contrast Ratio (CR)} = L_{63} / L_0$$

L63: Luminance of gray level 63, L0: Luminance of gray level 0

## Note4: Definition of Response Time (TR, TF)

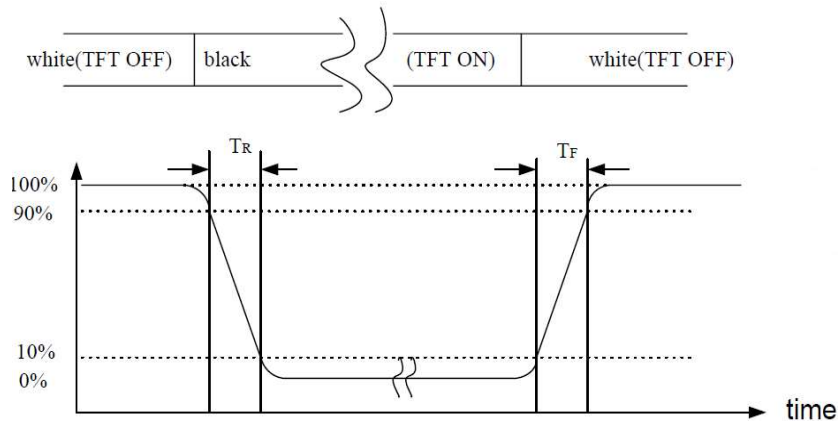

## Note5: Definition of Luminance White

Measure the luminance of gray level 63 at center point and 5 points.

Center of Luminance = Y1

$$\text{Average Luminance of 5 points} = \frac{Y_1 + Y_2 + Y_3 + Y_4 + Y_5}{5}$$

## Note6: Definition of Luminance Uniformity (Variation)

Measure the luminance of gray level 63 at 13 points.

$$\text{Uniformity of 13 points} = \frac{\text{Min Luminance of } Y_1 \sim Y_{13}}{\text{Max Luminance of } Y_1 \sim Y_{13}} \times 100\%$$

$$\text{Uniformity of 5 points} = \frac{\text{Min Luminance of } Y_1 \sim Y_5}{\text{Max Luminance of } Y_1 \sim Y_5} \times 100\%$$



## 6. RELIABILITY TEST ITEMS

### 6.1 TEMPERATURE AND HUMIDITY

No	Test Item	Test condition	Criterion
1	High Temperature Storage	60°C±2°C 96H Restore 2H at 25°C Power off	1. After testing, cosmetic and electrical defects should not happen. 2. Total current consumption should not be more than twice of initial value.
2	Low Temperature Storage	-10°C±2°C 96H Restore 2H at 25°C Power off	
3	High Temperature Operation	50°C±2°C 96H Restore 2H at 25°C Power on	
4	Low Temperature Operation	0°C±2°C 96H Restore 4H at 25°C Power on	
5	High Temperature/Humidity Operation	40°C±2°C 90%RH 96H Power on	
6	Temperature Cycle	- 10°C----->50°C 30min 5min 30min after 5 cycle, Restore 2H at 25°C Power off	
7	Vibration Test	10Hz~150Hz, 100m/s <sup>2</sup> , 120min	Not allowed cosmetic and electrical defects.
8	Shock Test	Half- sine wave,300m/s <sup>2</sup> ,11ms	
9	ESD Test	Air discharge:+/-6KV, Contact discharge:2KV	

Note: Operation: Supply 3.3V for logic system.

The inspection terms after reliability test, as below

ITEM	Inspection
Contrast	CR>50%
IDD	IDD<200%
Brightness	Brightness>60%
Color Tone	Color Tone+/-0,05



## 7. GENERAL PRECAUTION

### 7.1 SAFETY

1. Do not swallow any liquid crystal, even if there is no proof that liquid crystal is poisonous.
2. If the LCD panel breaks, be careful not to get liquid crystal to touch your skin.
3. If skin is exposed to liquid crystal, wash the area thoroughly with alcohol or soap.

### 7.2 STORAGE CONDITIONS

1. Store the panel or module in a dark place where the temperature is  $23\pm 5^{\circ}\text{C}$  and The humidity is below  $50\pm 20\%\text{RH}$ .
2. Store in anti-static electricity container.
3. Store in clean environment, free from dust, active gas, and solvent.
4. Do not place the module near organics solvents or corrosive gases.
5. Do not crush, shake, or jolt the module.

### 7.3 HANDLING PRECAUTIONS

- (1) Avoid static electricity which can damage the CMOS LSI.
- (2) The polarizing plate of the display is very fragile. So, please handle it very carefully.
- (3) Do not give external shock.
- (4) Do not apply excessive force on the surface.
- (5) Do not wipe the polarizing plate with a dry cloth, as it may easily scratch the surface of plate.
- (6) Do not use ketonic solvent & Aromatic solvent, use with a soft cloth soaked with a cleaning naphtha solvent.
- (7) Do not operate it above the absolute maximum rating.
- (8) Do not remove the panel or frame from the module.
- (9) When the module is assembled, it should be attached to the system firmly, Be careful not to twist and bend the module.
- (10) Wipe off water droplets or oil immediately. If you leave the droplets for a long time, staining and discoloration may occur.
- (11) If the liquid crystal material leaks from the panel, it should be kept away from the eyes or mouth. In case of contact with hands, legs or clothes, it must be washed away thoroughly with soap.

### 7.4 WARRANTY

- (1) The period is within twelve months since the date of shipping out under normal using and storage conditions.
- (2) Do not repaired or modified the LCM. It may cause function to lose efficacy, Starry does not warrant the LCM.
- (3) All process and material comply ROHS.