



SPECIFICATION FOR TFT LCD MODULE

CUSTOMER : _____

CUSTOMER MODULE : _____

HL MODEL : HG030FW006

Preliminary Specification

Final Specification

Customer Confirmation column:

Approved by : _____ Dept. : _____ Data : _____

Please return one of the copies of the specification with your signature to us within two weeks after you receive this document. If it is not returned, we will assume that you agree to the entire contents of this specification document.

Designed by	Checked by	Approved by



RECORDS OF REVISION

Date	Rev.	Description	Note	Page
2022\06\15	A	New sample		



Contents

1. SPECIFICATIONS

- 1.1 Features
- 1.2 Mechanical Specifications
- 1.3 Absolute Maximum Ratings
- 1.4 DC Electrical Characteristics
- 1.5 Optical Characteristics
- 1.6 Backlight

2. MODULE STRUCTURE

- 2.1 Counter Drawing
- 2.2 Interface Pin Description
- 2.3 Timing Characteristics
- 2.4 Display Command

3. INSPECTION SPECIFICATIONN

4. PRECAUTION RELATING PRODUCT HANDLING

- 4.1 Safety
- 4.2 Handling
- 4.3 Storage



1. SPECIFICATIONS

1.1 Features

Item	Standard Value
Display Type	360(R+G+B) * 640Dots
LCD Type	a-Si TFT, Positive, Transmissive
Viewing Direction	IPS
Backlight	6 LED White Color
Interface	MIPI / SPI+RGB16bit
Controller/driver IC	ST7701S

1.2 Mechanical Specifications

Item	Standard Value	Unit
Outline Dimension	40.84(W) x73.17(L)x2.05(T)	mm
Active Area	36.72(W) x 65.28(L)	mm
Pixel pitch	/	mm

Note: For detailed information please refer to LCM drawing

1.3 Absolute Maximum Ratings

Item	Symbol	Condition	Min.	Max.	Unit
Power Supply Voltage	V _{DD}	-	-0.3	4.6	V
LCD Driver Supply Voltage	V _{GH-VSS}	-	-0.3	18.5	V
Input voltage	V _{in}		-0.3	4.6	V
Operating Temperature	T _{OP}	-	-20	+70	°C
Storage Temperature.	T _{ST}	-	-30	+80	°C
Storage Humidity	H _D	T _a < 40 °C	-	90	%RH



1.4 DC Electrical Characteristics

$V_{DD} = 2.4 \sim 3.3V$, $V_{SS} = 0V$, $T_a = 25^\circ C$

Item	Symbol	Condition	Min.	Type	Max.	Unit
Logic Supply Voltage	V_{DD}	-	2.4	2.8	3.3	V
“H” Input Voltage	V_{IH}	-	$0.8 V_{DD}$	-	V_{DD}	V
“L” Input Voltage	V_{IL}	-	V_{SS}	-	$0.2 V_{DD}$	V
“H” Output Voltage	V_{OH}	-	$0.8V_{DD}$	-	V_{DD}	V
“L” Output Voltage	V_{OL}	-	V_{SS}	-	$0.2 V_{DD}$	V
Supply Current	I_{DD}	$V_{DD} = 2.8V$	-	4	6	mA

1.5 Optical Characteristics

$T_a = 25^\circ C$

Item	Symbol	Conditions	Min.	Typ.	Max.	Reference
View Angle	θ_{11}, θ_{12}	$C \geq 10, \phi = 0^\circ$	--	45	--	Note6-1
	θ_{21}		--	45	--	Note6-1
	θ_{22}		--	45	--	Note6-1
Contrast Ratio	C	$\theta = 0^\circ, \phi = 0^\circ$	150	250	-	--
Response Time(rise)	tr	$\theta = 0^\circ, \phi = 0^\circ$	-	10ms	20ms	Note6-3
Response Time(fall)	tf	$\theta = 0^\circ, \phi = 0^\circ$	-	20ms	30ms	Note6-3
Luminance	B	$\theta = 0^\circ \quad \phi = 0^\circ$	-		-	cd/m ²



Note 6-1 : The definitions of viewing angles

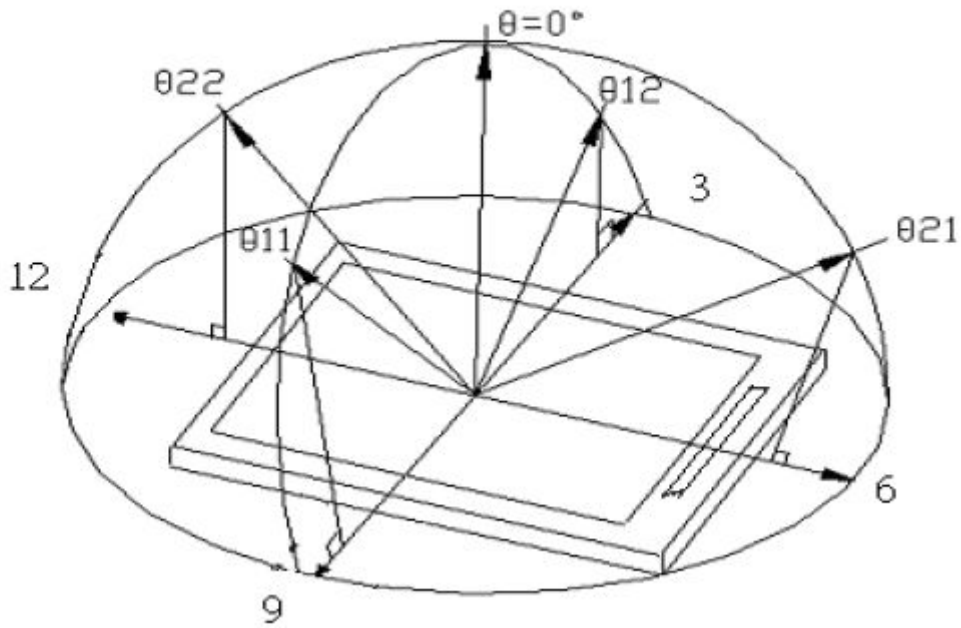

Note 6-3 : The definition of response time :

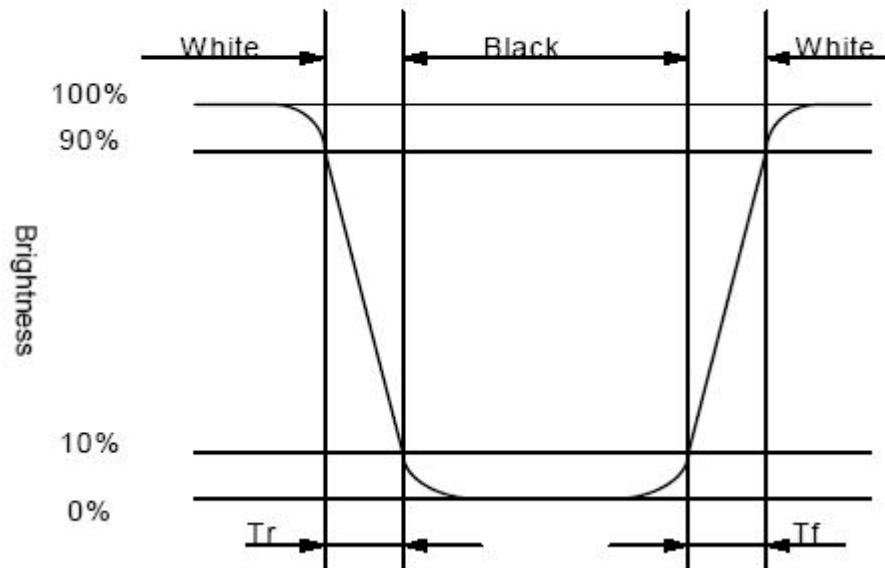



1.6 Backlight & LED Characteristics

Maximum Ratings

Item	Symbol	Conditions	Min.	Max.	Unit
Forward Current	IF	Ta =25℃	-	20 (1 LED)	mA
Reverse Voltage	VR	Ta =25℃	-	5	V
Power Dissipation	PO	Ta =25℃	-	198	mW
Operating Temperature	T _{OP}	-	-20	70	℃
Storage Temperature	T _{ST}	-	-30	80	℃
Solder Temp. for 3 Seconds	-	-	-	260	℃

Electrical / Optical Characteristics

VSS = 0V, Ta =25℃

Item	Symbol	Conditions	Min.	Typ.	Max.	Unit
Forward Voltage	VF	IF= 20mA	18	19.2	20	V
Reverse Current	IR	-	-	-	-	uA
Average Brightness	IV	-	-	400	-	cd/m ²
CIE Color Coordinate (without LCD)	X	-	-	-	-	—
	Y		-	-	-	
Color	WHITE					

*1 This value will be changed while mass production.



2. MODULE STRUCTURE

2.1 Counter Drawing

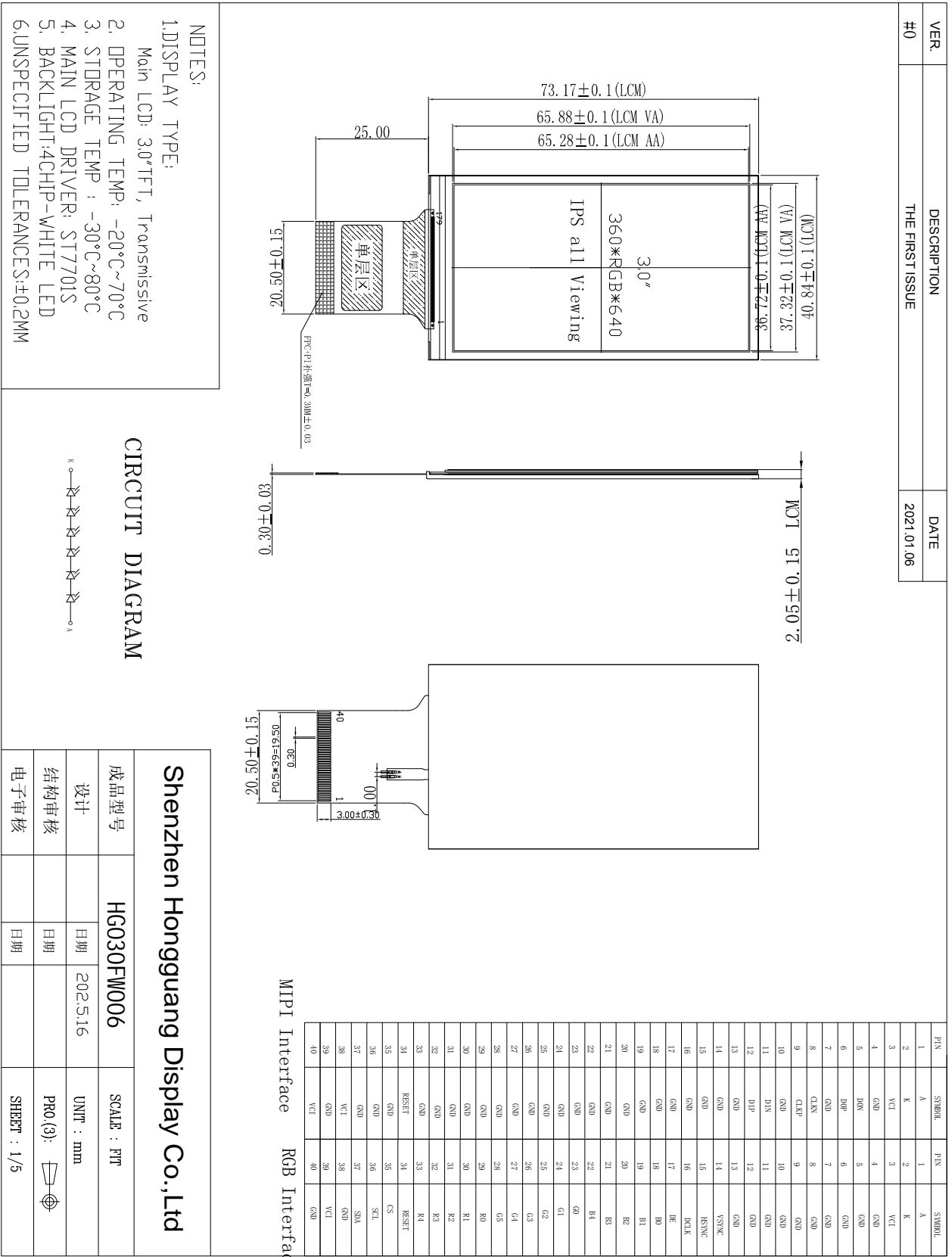



Interface Pin Description

Pin.No	Symbol	Function
1	A	Anode of Backlight
2	K	Cathode of Backlight
3	VCI	Power supply for LCM(2.8V)
4	GND	Power ground
5	D0N	Differential data pairs for MIPI interface.
6	D0P	Differential data pairs for MIPI interface.
7	GND	Power ground
8	CLK_N	Differential clock or strobe pair for MIPI interfaces.
9	CLK_P	Differential clock or strobe pair for MIPI interfaces.
10	GND	Power ground
11	D1N	Differential data pairs for MIPI interface.
12	D1P	Differential data pairs for MIPI interface.
13	GND	Power ground
14	VSYNC	Frame Synchronizing Signal For RGB Interface
15	HSYNC	Line Synchronizing Signal For RGB Interface
16	DCLK	Dot Clock Signal For RGB Interface
17	DE	Data Enable Signal For RGB Interface
18-22	B0-B4	Bule data
23-28	G0-G5	Green data
29-33	R0-R4	Red data
34	RESET	Reset signal
35	CS	Chip select input pin
36	SCL	Serial clock input pin
37	SDA	Serial data input pin
38	IM0	MIPI : IM0=1,IM1=0,IM2=1 ; SPI+RGB: IM0=0,IM1=1,IM2=0 .
39	IM1	
40	IM2	



2.3 Timing Characteristics

Please refer to ST7701S DATASHEET.

2.4 Display Command

Please refer to ST7701S DATASHEET.

3. INSPECTION SPECIFICATIONN

NO.	项目 Item	经验标准 Inspection Standard	判断 Result	备注 Note
1	整体功能 All functional defects	1) 不显示 No display 2) 显示异常 Display abnormally 3) 缺划（横或竖，横&竖） Missing vertical, horizontal segment 4) 短路 Short circuit 5) 背光不亮或闪烁 Backlight no lighting, flickering and abnormal lighting.	不允许 Reject	
2	缺失 Missing	少成分 Missing component	不允许 Reject	
3	外观尺寸 Outline dimension	同 CD 图 Overall outline dimension beyond the drawing is not allowed		

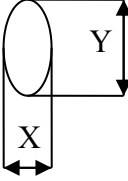
NO.	项目 Item	检验标准 Inspection Standard	备注 Note
4	清楚的黑白点 Clear Spots	$\phi = (X+Y) / 2$ A: AA 区 (显示区) B: VA 区 (可视区) C: 可视区以外(Out of VA) 	

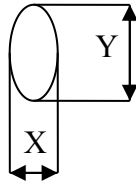

		区域 Zone 尺寸 Size	接受个数 Acceptable Quantity		
			A	B	C
		$\phi \leq 0.1\text{mm}$	Ignore		Ignore
		$0.1\text{mm} < \phi \leq 0.2\text{mm}$	3		
		$0.2\text{mm} < \phi \leq 0.25\text{mm}$	2		
$\phi > 0.25\text{mm}$	0				

NO.	项目 Item	检验标准 Inspection Standard	备注 Note																								
5	不明显的黑白点 Dim Spots	$\phi = (X+Y) / 2$  <p>A: AA 区 (显示区) B: VA 区 (可视区) C: 可视区以外(Out of V.A.)</p> <table border="1" data-bbox="459 1288 1050 1630"> <tr> <td rowspan="2">区域 Zone 尺寸 Size</td> <td colspan="3">接受个数 Acceptable Quantit</td> </tr> <tr> <td>A</td> <td>B</td> <td>C</td> </tr> <tr> <td>$\phi \leq 0.3\text{mm}$</td> <td colspan="2">Ignore</td> <td rowspan="3">Ignore</td> </tr> <tr> <td>$0.3\text{mm} < \phi \leq 0.6\text{mm}$</td> <td colspan="2">2</td> </tr> <tr> <td>$\phi > 0.6\text{mm}$</td> <td colspan="2">0</td> </tr> </table>	区域 Zone 尺寸 Size	接受个数 Acceptable Quantit			A	B	C	$\phi \leq 0.3\text{mm}$	Ignore		Ignore	$0.3\text{mm} < \phi \leq 0.6\text{mm}$	2		$\phi > 0.6\text{mm}$	0									
区域 Zone 尺寸 Size	接受个数 Acceptable Quantit																										
	A	B	C																								
$\phi \leq 0.3\text{mm}$	Ignore		Ignore																								
$0.3\text{mm} < \phi \leq 0.6\text{mm}$	2																										
$\phi > 0.6\text{mm}$	0																										
6	线不良 Line defect	<table border="1" data-bbox="459 1680 1252 2018"> <tr> <td colspan="2">尺寸 Size (mm)</td> <td colspan="3">接受个数 Acceptable Quantity</td> </tr> <tr> <td>L (Length)</td> <td>W (width)</td> <td>A</td> <td>B</td> <td>C</td> </tr> <tr> <td>Ignore</td> <td>$W \leq 0.03$</td> <td colspan="3">Ignore</td> </tr> <tr> <td>$L < 5.0$</td> <td>$0.03 < W \leq 0.05$</td> <td colspan="2">2</td> <td rowspan="2">Ignore</td> </tr> <tr> <td></td> <td>$0.05 < W$</td> <td colspan="2">以脏污论 Define as spot</td> </tr> </table>	尺寸 Size (mm)		接受个数 Acceptable Quantity			L (Length)	W (width)	A	B	C	Ignore	$W \leq 0.03$	Ignore			$L < 5.0$	$0.03 < W \leq 0.05$	2		Ignore		$0.05 < W$	以脏污论 Define as spot		
尺寸 Size (mm)		接受个数 Acceptable Quantity																									
L (Length)	W (width)	A	B	C																							
Ignore	$W \leq 0.03$	Ignore																									
$L < 5.0$	$0.03 < W \leq 0.05$	2		Ignore																							
	$0.05 < W$	以脏污论 Define as spot																									



					defect	
7	偏光片刮伤 Polarizer Scratch	尺寸 Size (mm)		Acceptable Quantity		
		L (Length)	W (width)	A	B	C
		Ignore	$W \leq 0.03$	Ignore		
		$L \leq 10$	$0.03 < W \leq 0.05$	2	Ignore	
		$L < 5.0$	$0.05 < W \leq 0.08$	1	Ignore	
			$0.08 < W$	0	Ignore	
8	偏光片与玻璃间气泡 Polarize Air bubble	区域 Zone 尺寸 Size		接受个数 Acceptable Quantity		
				A	B	C
		$\phi \leq 0.2\text{mm}$		Ignore		
		$0.2\text{mm} < \phi \leq 0.3\text{mm}$		2	Ignore	
		$0.3\text{mm} < \phi \leq 0.5\text{mm}$		1	Ignore	
		$\phi > 0.5\text{mm}$		0	Ignore	

牛顿环/干涉纹 Newton Ring

NO.	项目 Item	检验标准 Inspection Standard	备注 Note
-----	------------	-----------------------------	------------

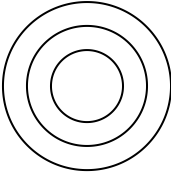
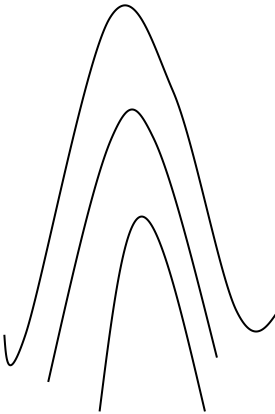

9	规则 Inerratic	<ol style="list-style-type: none">1. 在整个触摸屏检查区域内（可视区）超过 1/3 范围, 不可; When Newton ring dimension is more than 1/3 of sample dimension, it is regarded as a defect.2. 直径$\leq 5\text{mm}$, 且在整个触摸屏检查区（可视区）域小于 1/3 范围, 不影响透过率及失真; 不计 When Newton ring dimension is less than 1/3 of sample dimension is not affect font effect and line distortion under a ceiling fluorescent light, it is acceptable.	
10	不规则 Atactic	<ol style="list-style-type: none">1. 在照明环境下牛顿环有影响清晰度和透过率, 失真; 不可。As long as Newton ring affects font effect and line distortion under a ceiling fluorescent light, it is regarded as a defect. <p>在整个触摸屏检查区域(可视区)内, 超过 1/2, 不可。 $\phi \leq 10\text{mm}$; 不计。 When $\phi \leq 10\text{mm}$, it is acceptable</p>	



4. PRECAUTION RELATING PRODUCT HANDLING

4.1 SAFETY

- 4.1.1 If the LCD panel breaks , be careful not to get the liquid crystal to touch your skin.
- 4.1.2 If the liquid crystal touches your skin or clothes , please wash it off immediately by using soap and water.

4.2 HANDLING

- 4.2.1 Avoid any strong mechanical shock which can break the glass.
- 4.2.2 Avoid static electricity which can damage the CMOS LSI—When working with the module, be sure to ground your body and any electrical equipment you may be using.
- 4.2.3 Do not remove the panel or frame from the module.
- 4.2.4 The polarizing plate of the display is very fragile. So , please handle it very carefully, Do not touch, push or rub the exposed polarizing with anything harder than an HB pencil lead (glass , tweezers , etc.)
- 4.2.5 Do not wipe the polarizing plate with a dry cloth, as it may easily scratch the Surface of plate.
- 4.2.6 Do not touch the display area with bare hands , this will stain the display area.
- 4.2.7 Do not use ketonic solvent & aromatic solvent. Use with a soft cloth soaked with A cleaning naphtha solvent.
- 4.2.8 To control temperature and time of soldering is $280 \pm 10^{\circ}\text{C}$ and 3-5 sec.
- 4.2.9 To avoid liquid (include organic solvent) stained on LCM.

4.3 STORAGE

- 4.3.1 Store the panel or module in a dark place where the temperature is $25^{\circ}\text{C} \pm 5^{\circ}\text{C}$ and the humidity is below 65% RH.
- 4.3.2 Do not place the module near organics solvents or corrosive gases.
- 4.3.3 Do not crush, shake , or jolt the module.