



# SPECIFICATION FOR TFT LCD MODULE

CUSTOMER : \_\_\_\_\_

CUSTOMER MODULE : \_\_\_\_\_

HL MODEL :     HG040HH005    

**■Final Specification**

Customer Confirmation column:

\_\_\_\_\_ Dept. : \_\_\_\_\_ Data : \_\_\_\_\_

Please return one of the copies of the specification with your signature to us within two weeks after you receive this document. If it is not returned, we will assume that you agree to the entire contents of this specification document.

Designed by	Checked by	Approved by



Revision History

Version NO.	DATE	Description	Remak
V1.0	2023.10.18	FIRST ISSUE	



## 1.General Description

HG040HH005 is a color active matrix TFT LCD module using amorphous silicon TFT's (Thin Film Transistors) as an active switching devices. This module has a 4.0 inch diagonally measured active area with HD resolutions (720 horizontal by 720 vertical pixel array). Each pixel is divided into RED, GREEN, BLUE dots which are arranged in vertical stripe and this module can display 16.7M colors. The TFT-LCD panel used for this module is adapted for a low reflection and higher color type.

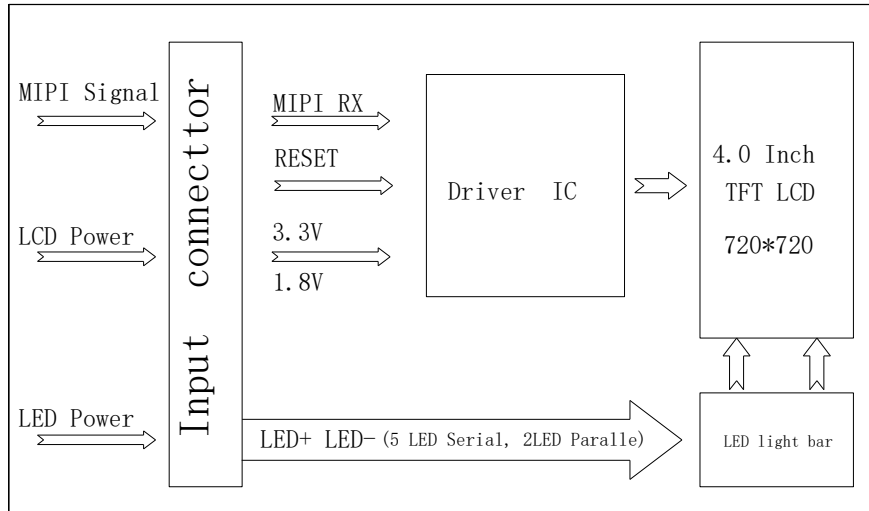

## 2. General Specifications

No.	Item	Specification	Unit
1	LCD size	4.0	inch
2	Pixel pitch	0.047(H) × R G B × 0.141(V)	mm
3	Active area	101.52(H)X101.52(V)	mm
4	Module size	107.60(H)X111.87 (V)X3.8(T)	mm
5	LCM+CTP size	TBD	
6	Number of pixel	720 RGB(H)X720 (V)	pixels
7	Number of colors	16.7M	colors
8	Interface	MIPI	
9	Driver IC	JD9365DA-H3	
10	Display mode	Normally Black	
11	Pixel arrangement	RGB Vertical stripe	
12	Surface Treatment	Glare	
13	LCM Brightness	1500(Typ)	cd/m2
14	Backlight power consumption	3.84(Max)	W
15	Panel power consumption	TBD	W
16	Module Weight	TBD	g



## 3.Outline Dimension

由 Autodesk 教育版产品制作

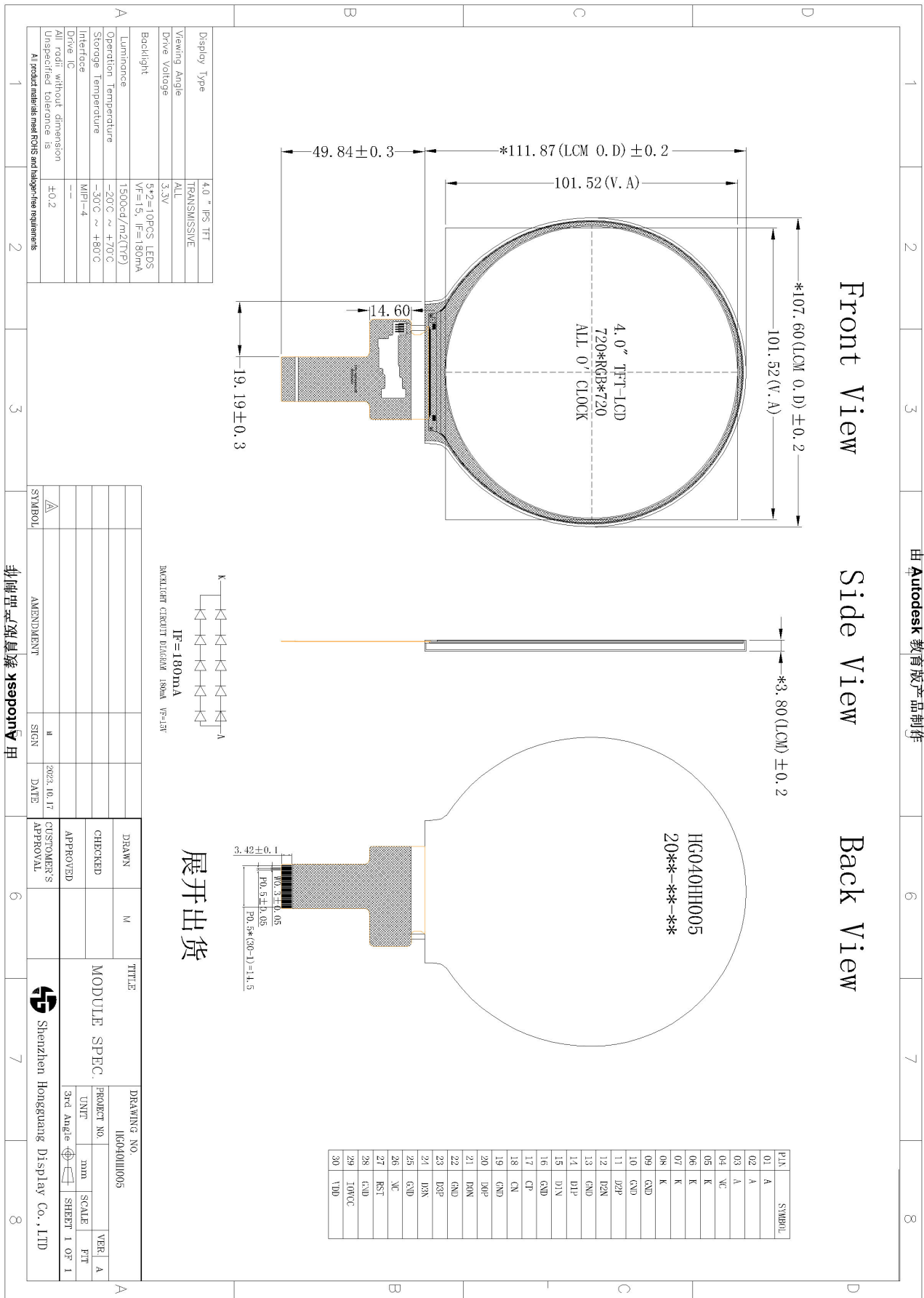

由 Autodesk 教育版产品制作

由 Autodesk 教育版产品制作



## 4.Interface Definition

Pin No.	Symbol	Function	Notes
1	LEDA	Backlight Anode	
2	LEDA	Backlight Anode	
3	LEDA	Backlight Anode	
4	NC	No Connection	
5	LEDK	Backlight Cathode	
6	LEDK	Backlight Cathode	
7	LEDK	Backlight Cathode	
8	LEDK	Backlight Cathode	
9	GND	Ground	
10	GND	Ground	
11	D2+	MIPI differential data input (Positive)	
12	D2-	MIPI differential data input (Negative)	
13	GND	Ground	
14	D1+	MIPI differential data input (Positive)	
15	D1-	MIPI differential data input (Negative)	
16	GND	Ground	
17	CLK+	MIPI differential clock input (Positive)	
18	CLK-	MIPI differential clock input (Negative)	
19	GND	Ground	
20	D0+	MIPI differential data input (Positive)	
21	D0-	MIPI differential data input (Negative)	
22	GND	Ground	
23	D3+	MIPI differential data input (Positive)	
24	D3-	MIPI differential data input (Negative)	
25	GND	Ground	
26	IOVCC	Power supply 1.8V/3.3V	
27	RST(GRB)	LCM Global reset	
28	GND	Ground	
29	IOVCC_1.8V	Power supply 1.8V/3.3V	
30	VCC_3.3V	Power supply 3.3V	



## 5. Operation Specifications

### 5.1 Absolute Max. Rating

The following are maximum values which, if exceeded, may cause faulty operation or damage to the unit.

Item	Symbol	Values		Unit	Remark
		Min.	Max.		
Power Voltage	IOVCC			V	
	VCC	-0.3	3.6	V	
	AVEE	-	-	V	
Input Signal Voltage	V <sub>I</sub>	-0.3	IOVCC	V	
Operation Temperature	T <sub>OP</sub>	-20	70	°C	
Storage Temperature	T <sub>ST</sub>	-30	80	°C	

Note: The absolute maximum rating values of this product are not allowed to be exceeded at any times. Should a module be used with any of the absolute maximum ratings exceeded, the characteristics of the module may not be recovered, or in an extreme case, the module may be permanently destroyed. There is a risk of permanent damage to the product.

### 5.2 Electrical Characteristic

Characteristics	Symbol	Min.	Typ.	Max.	Unit
Supply Voltage for I/O	VDDIO	1.65	1.8	3.6	V
Supply Voltage for(DC/DC)	VDD	2.5	3.3	3.6	V
Supply Voltage for(DC/DC)	AVDD				V
Supply Voltage for(DC/DC)	AVEE				V
Current Consumption	IDD	-	TBD	-	mA
	IDD-SLE EP		TBD		uA



### 5.3 Back-Light Unit Characeristics

The back-light system is an edge-lighting type with white LEDs. The characteristics of the back-light are shown in the following tables.

Characteristics	Symbol	Min.	Type	Max.	Unit	Notes
Forward Voltage	V <sub>F</sub>	14.5	15	16	V	-
Forward current	I <sub>F</sub>	--	180	-	mA	-
Luminance(With LCD)	L <sub>v</sub>		1500	--	cd/m <sup>2</sup>	-
LED life time	N/A	----	30,000	--	Hr	Note 1

Note: 1. The figure below shows the connection of backlight LED.

2. One LED: I<sub>F</sub>=90mA, V<sub>F</sub>=2.9V

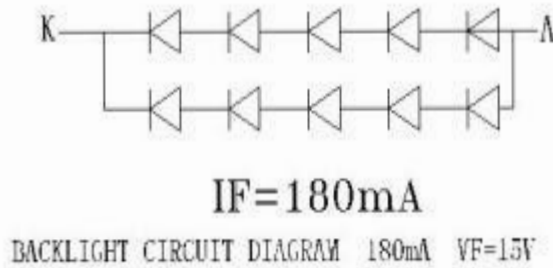



## 6.Signal Timing Characteristics

### 6.1 Power on/off Sequence

Symbol	Min	Typ	Max	Unit	Remark
tRamp	-	no limit	-	us	
tPWON	0	-	-	ms	
tONI	0	-	-	ms	
tMIPI-ON	0	-	tRPWIRES	ms	
tRPWIRES	5	-	-	ms	
tRESETL	10	-	-	us	
tRESETH	5	-	-	ms	
tSLPOUT	120	-	-	ms	
tBLON	0	-	-	ms	

BOOSTM[1:0]=10 (Internal DC/DC power mode : Charge Pump, FP7721)  
 VCCD=IOVCC=VCCH=1.65V ~ 3.6V, VCI=VCIP=2.5V ~ 4.8V.  
 Power on:

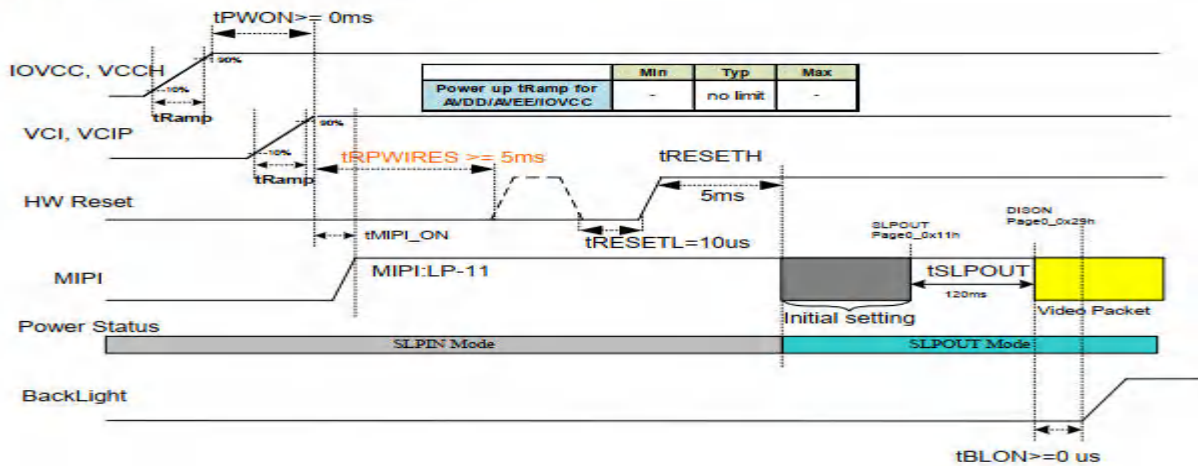

BOOSTM[1:0]=10 (Internal DC/DC power mode : Charge Pump, FP7721)  
 VCCD=IOVCC=VCCH=1.65V ~ 3.6V, VCI=VCIP=2.5V ~ 4.8V.  
 Power off: Case2

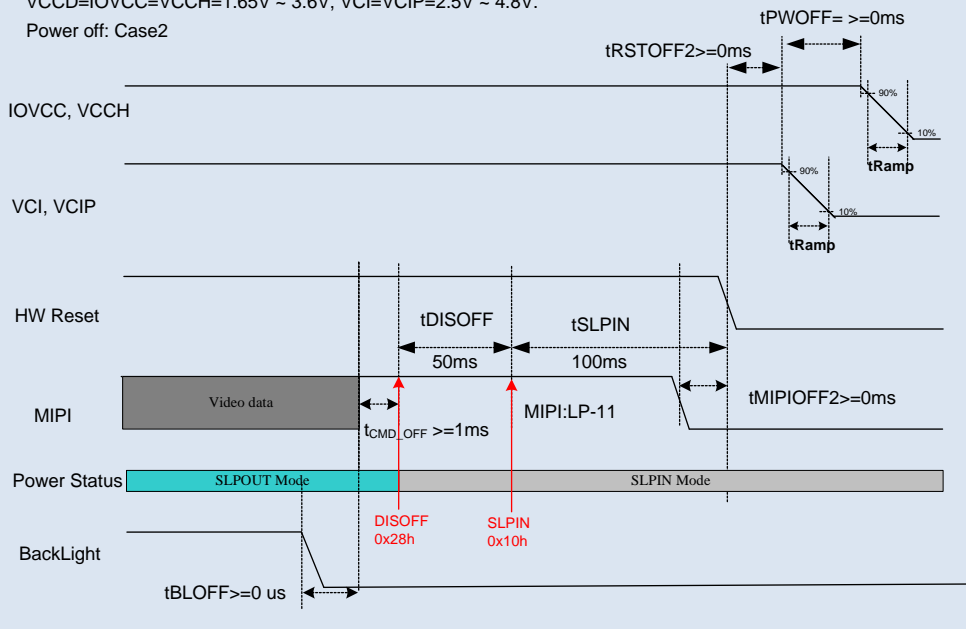

### 6.2 Timing Parameters

Parameter	Symbol	Min	Typ	Max	Unit	Condition
MIPI digital operation current.	I <sub>VCCIF</sub>	14	15	16	mA	-
MIPI digital stand-by current.	I <sub>VCCIFST</sub>	-	200	-	uA	-





MIPI Characteristics for High Speed Receiver							
Single-ended input low voltage	$V_{ILHS}$	-40	-	-		mV	
Single-ended input high voltage	$V_{IHHS}$	-	-	460		mV	
Common-mode voltage	$V_{CMRXDC}$	70	-	330		mV	
Differential input impedance	$Z_{ID}$	80	100	125		K	
HS transmit differential voltage ( $V_{OD}=V_{DP}-V_{DN}$ )	$ V_{OD} $	85	200	250		mV	
MIPI Characteristics for Low Power Receiver							
Pad signal voltage range.	$V_I$	-50	-	1350		mV	
Ground shift.	$V_{GNDSH}$	-50	-	50		mV	
Output low level	$V_{OL}$	-50	-	50		mV	
Output high level	$V_{OH}$	1.1	1.2	1.3		V	

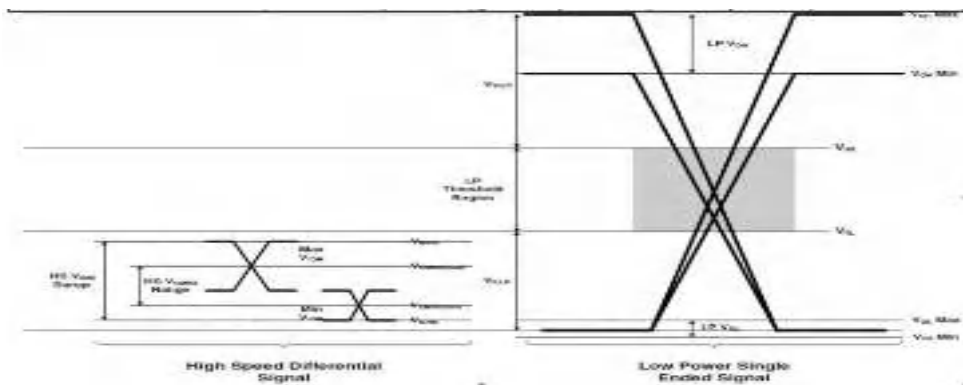



## 7. Optical specifications

Optical characteristics are determined after the unit has been 'ON' and stable for approximately 5 minutes in a dark environment at 25°C.

Parameter	Symbol	Condition	Min.	Typ.	Max.	Unit	Remark		
Viewing Angle range	Horizontal	$\Theta_3$	80	85	-	Deg.	Note 1		
		$\Theta_9$	80	85	-	Deg.			
	Vertical	$\Theta_{12}$	80	85	-	Deg.			
		$\Theta_6$	80	85	-	Deg.			
Luminance Contrast ratio	CR		1000	1200	-		Note 2		
Transmittance (pol)	T(%)		4.55	5.35	-	%	@Silicate BLU POL:HC+ Clear Note 3		
White luminance uniformity	$\Delta Y$					%			
White Chromaticity	$x_w$	$\Theta = 0^\circ$ (Center) Normal Viewing Angle	0.262	0.292	0.322		CF @C Light Note 4		
	$y_w$		0.307	0.337	0.367				
Reproduction of color	Red		$x_R$	0.620	0.650	0.680			
			$y_R$	0.292	0.322	0.352			
	Green		$x_G$	0.250	0.280	0.310			
			$y_G$	0.533	0.563	0.593			
	Blue		$x_B$	0.105	0.135	0.165			
			$y_B$	0.111	0.141	0.171			
Response Time (Rising + Falling)	$T_{RT}$		$T_a = 25^\circ C$ $\Theta = 0^\circ$	-	30	35		ms	Note 5

### Note :

- Viewing angle is the angle at which the contrast ratio is greater than 10. The viewing are determined for the horizontal or 3, 9 o'clock direction and the vertical or 6, 12 o'clock direction with respect to the optical axis which is normal to the LCD surface.
- Contrast measurements shall be made at viewing angle of  $\theta = 0^\circ$  and at the center of the LCD surface. Luminance shall be measured with all pixels in the view field set first to white, then to the dark (black) state. (See FIGURE 1 shown in Appendix) Luminance Contrast Ratio (CR) is defined mathematically.

$$CR = \frac{\text{Luminance when displaying a white raster}}{\text{Luminance when displaying a black raster}}$$

- Transmittance is the Value with Polarizer(HC+Clear) & silicate BLU (Film structure is on Table 4.1)
- The color chromaticity coordinates specified in the above Table shall be calculated from the spectral data measured with all pixels first in red, green, blue and white. Measurements shall be made at the center of the panel.



5. The electro-optical response time measurements shall be made as **FIGURE 1** shown in Appendix. The times needed for the luminance to change from 10% to 90% is  $T_r$ , and 90% to 10% is  $T_f$ .

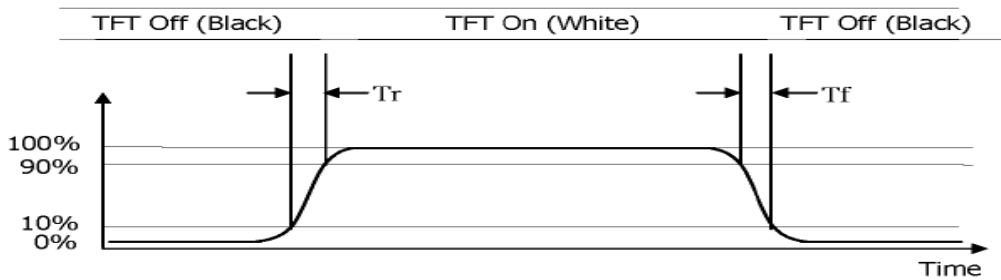

## 8. Reliability Test Items

No	Test Items	Conditions
1	High temperature storage test	Ta = 80 °C, 240 hrs
2	Low temperature storage test	Ta = -30 °C, 240 hrs
3	High temperature operation test	Ta = 70 °C, 240 hrs
4	Low temperature operation test	Ta = -20 °C, 240 hrs
5	High temperature & high humidity operation test	Ta = 60 °C, 90%RH, 240 hrs
6	Thermal shock	Ta = -20 °C ↔ 70 °C (0.5 hr), 100 cycle

Note :

1. After the reliability test, the product only guarantee function normally without any fatal defect (non-display, line defect, abnormal display etc ). All the cosmetic specification is judged before the reliability test.
2. The reliability test result is based on ICNL9707 IC, and the operation temperature of this IC is the same to MDL, 85°C. There is no margin left. Refer to experience, when ambient temperature is 85°C, the temperature of IC would be beyond 85°C. So there has a risk that the IC might shut down.



## 9. Packing and Label Format

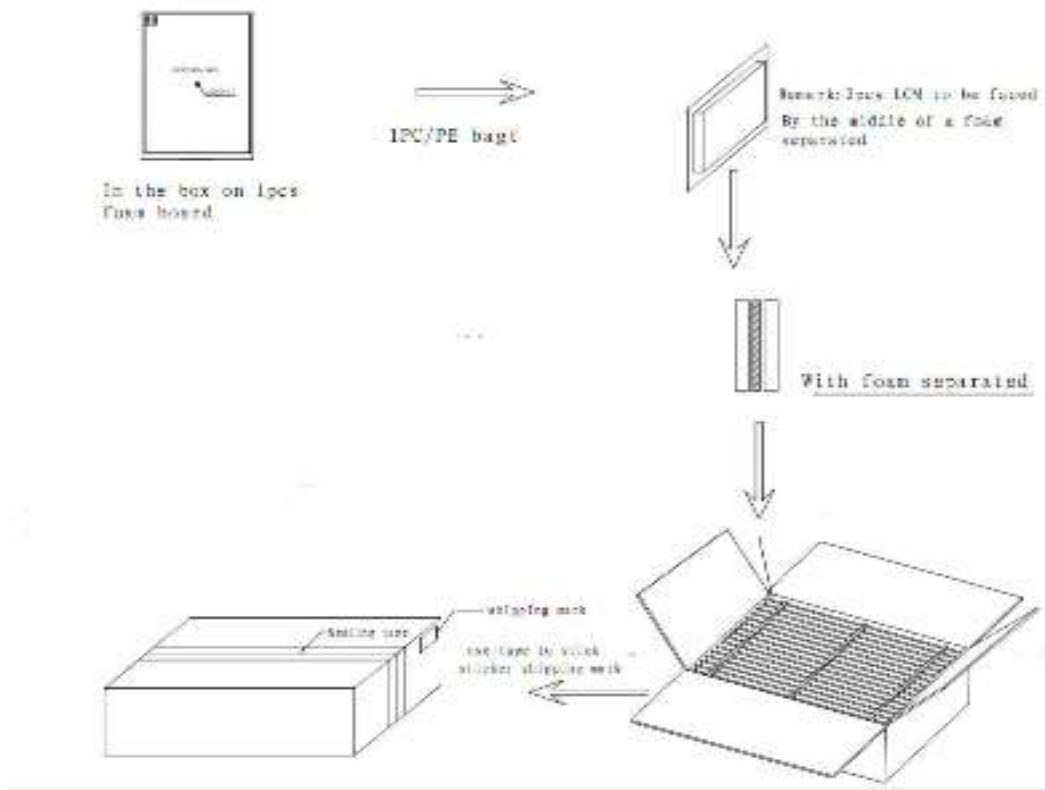



## 10.0 PRECAUTIONS

### 10.1 Handling

- (1) Use fingerstalls with soft gloves in order to keep display clean during the incoming inspection and assembly process.
- (2) You must mount a module using specified mounting holes (Details refer to the drawings).
- (3) Please make sure to avoid external forces applied to the Source PCB or FPC and D-IC during the process of handling or assembling. If not, It causes panel damage or malfunction.
- (4) Note that LCD surface are very fragile and could be easily damaged. Do not touch, push or rub the exposed LCD surface with glass, tweezers or anything harder than HB pencil lead. And please do not rub with dust clothes with chemical treatment.
- (5) Do not pull or fold the source D-IC which connect the source PCB or FPC and the panel. Do not pull or fold the LED wire.
- (6) After removing the protective film, when the surface becomes dusty, please wipe gently with absorbent cotton or other soft materials like chamois soaks with alcohol or purified water. Do not strong polar solvent because they cause chemical damage to the polarizer
- (7) Wipe off saliva or water drops as soon as possible. Their long time contact with LCD surface causes deformations and color fading.
- (8) Protection film for LCD surface on the module shall be slowly peeled off just before use so that the electrostatic charge can be minimized.
- (9) Since the LCD is made of glass, do not apply strong mechanical impact or static load onto it. Handling with care since shock, vibration, and careless handling may seriously affect the product. If it falls from a high place or receives a strong shock, the glass may be broken.
- (10) Do not disassemble the module.
- (11) To determine the optimum mounting angle, refer to the viewing angle range in the specification for each model.
- (12) If the customer's set presses the main parts of the LCD, the LCD may show the abnormal display. But this phenomenon does not mean the malfunction of the LCD and should be pressed by the way of mutual agreement.
- (13) Do not drop water or any chemicals onto the LCD's surface.
- (14) The ITO pad area needs special careful caution because it could be easily corroded. Do not contact the ITO pad area with HCFC, Soldering flux, Chlorine, Sulfur, saliva or fingerprint. To prevent the ITO corrosion, customers are recommended that the ITO area would be covered by UV or silicon.



## 10.2 Operating Precautions

- (1) Be careful for condensation at sudden temperature change. Condensation makes damage to LCD surface or electrical contacted parts. And after fading condensation, smear or spot will occur.
- (2) Module has high frequency circuits. Sufficient suppression to the electromagnetic interference shall be done by system manufacturers. Grounding and shielding methods may be important to minimized the interference.
- (3) The electrochemical reaction caused by DC voltage will lead to LCD degradation, so DC drive should be avoided.
- (4) The LCD modules use C-MOS LSI drivers, so customers are recommended that any unused input terminal would be connected to Vdd or Vss, do not input any signals before power is turn on, and ground you body, work/assembly area, assembly equipments to protect against static electricity.
- (5) Do not exceed the absolute maximum rating value. (supply voltage variation, input voltage variation, variation in part contents and environmental temperature, and so on) Otherwise the Module may be damaged.
- (6) Design the length of cable to connect between the connector for back-light and the converter as short as possible and the shorter cable shall be connected directly. The longer cable between that of back-light and that of converter may cause the luminance of LED to lower and need a higher startup voltage(Vs).
- (7) Connectors are precise devices for connecting PCB and transmitting electrical signals. Operators should insert and unplug MDL in parallel when assembling MDL.
- (8) Do not connect or disconnect the cable to/ from the module at the "Power On" condition.
- (9) When the module is operating, do not lose CLK, HS, VS signals. If any one these signals is lost, the LCD panel would be damaged.
- (10) Obey the supply voltage sequence. If wrong sequence is applied, the module would be damaged.
- (11) Do not re-adjust variable resistor or switch etc.



## 10.3 Electrostatic Discharge Control

- (1) Since a module is composed of electronic circuits, it is not strong to electrostatic discharge. Make certain that treatment persons are connected to ground through wrist band etc. And don't touch interface pin directly. Keep products as far away from static electricity as possible.
- (2) Avoid the use work clothing made of synthetic fibers. We recommend cotton clothing or other conductivity-treated fibers.

## 10.5 Precautions for Strong Light Exposure

Strong light exposure causes degradation of polarizer and color filter. It is not allowed to store or run directly in strong light or in high temperature and humidity for a long time.

## 10.5 Storage Precautions

- (1) When storing the LCD modules, avoid exposure to direct sunlight or to the light of fluorescent lamps.
- (2) The LCD modules should be stored under the storage temperature range. the recommend condition is: Temperature : 0°C~ 40°C, Relatively humidity: ≤80%, and no more than 1 year.
- (3) The LCD modules should be stored in the room without acid, alkali and harmful gas.

## 10.6 Handling Precautions for Protection Film ( 不适用于Q/Single出货产品 )

- (1) Remove the protective film slowly, keeping the removing direction approximate 30-degree not vertical from panel surface, If possible, under ESD control device like ion blower, and the humidity of working room should be kept over 50%RH to reduce the risk of static charge.
- (2) In handling the LCD, wear non-charged material gloves. And the conducting wrist to the earth and the conducting shoes to the earth are necessary.

## 10.7 Operation Condition Guide

- (1) Lifetime in this spec. is guaranteed only when Commercial Display is used according to operating usages.
- (2) Module used in unnormal orientation mode , need to confirm with the manufacturer.
- (3) Do not exceed the absolute maximum rating value. (supply voltage variation, input voltage variation, variation in part contents and environmental temperature, and so on) Otherwise the Module may be damaged.



- (4) Dew drop atmosphere should be avoided.
- (5) The storage room should be equipped with a good ventilation facility, which has a temperature controlling system.
- (6) When expose to drastic fluctuation of temperature (hot to cold or cold to hot ) ,the LCD may be affected; Specifically, drastic temperature fluctuation from cold to hot ,produces dew on the LCD's surface which may affect the operation of the polarizer and the LCD.
- (7) Response time will be extremely delayed at lower temperature than the operating temperature range and on the other hand at higher temperature LCD may turn black at temperature above its operational range. However those phenomena do not mean malfunction or out of order with the LCD. The LCD will revert to normal operation once the temperature returns to the recommended temperature range for normal operation.

## 10.8 Others

- (1)When returning the module for repair or etc., Please pack the module not to be broken. We recommend to use the original shipping packages.
- (2) In order to prevent potential problems, flicker should be adjusted by optimizing the Vcom value in customer LCM. ( 适用于Q panel/single/OC出货 )
- (3) If the liquid crystal material leaks from the panel, it should be kept away from the eyes or mouth. In case of contact with hands, legs or clothes, it must be washed away thoroughly with soap.
- (4) For the crash damaged or unnecessary LCD, it is recommended to wash off liquid crystalby either of solvents such as acetone and ethanol an should be burned up later.
- (5) If you should swallow the liquid crystal, first, wash your mouth thoroughly with water, then drink a lot of water and induce vomiting, and then, consult a physician.
- (6) If the liquid crystal should get in your eyes, flush your eyes with running water for at least fifteen minutes.
- (7) Client needs to add heat dissipation design , such as fan, water cooling , etc.
- (8) After assembling into modules, guarantee that the temperature rise of panel surface does not exceed 20 °C at room temperature.