



SPECIFICATION FOR TFT LCD MODULE

CUSTOMER : _____

CUSTOMER MODULE : _____

HL MODEL : HG069HS004

Preliminary Specification

Final Specification

Customer Confirmation column:

Approved by : _____ Dept. : _____ Data : _____

Please return one of the copies of the specification with your signature to us within two weeks after you receive this document. If it is not returned, we will assume that you agree to the entire contents of this specification document.

Designed by	Checked by	Approved by



REVISION STATUS

Version	Revise Date	Page	Content	Modified by
V1.0	2019.04.25	-	First Issued.	



TABLE OF CONTENTS

No.	CONTENTS	PAGE
	REVISION STATUS	1
	TABLE OF CONTENTS.....	3
1.	GENERAL DESCRIPTION	4
2.	MECHANICAL SPECIFICATION	5
3.	PIN DESCRIPTION	6
4.	ELECTRICAL CHARACTERISTICS	7
5.	INPUT SIGNAL TIMING	10
6.	OPTICAL CHARACTERISTICS	13
7.	RELIABILITY TEST ITEMS	15
8.	GENERAL PRECAUTION	16
9.	INSPECTION STANDARDS	17
10.	PACKAGE DRAWING.....	20

1. GENERAL DESCRIPTION

1.1 DESCRIPTION

This LCM is a color active matrix thin film transistor (TFT) IPS liquid crystal display (LCD) that uses amorphous silicon TFT as a switching device. It is composed of a TFT LCD panel, Driver IC, FPC and Backlight. This TFT LCD has a 6.86-inch diagonally measured active display area with (480 horizontal by 1280 vertical pixel) resolution.

1.2 FEATURES:

No.	Item	Specification	Unit
1	Panel Size	6.86"	inch
2	Number of Pixels	480×RGB (3)×1280	pixels
3	Active Area	60.22(H)x 160.59(V)	mm
4	Pixel Pitch	41.82(H)×125.46(V) x RGB	um
5	Outline Dimension	66.6(W)×181.0(H)×7.15 (D)	mm
6	Number of Colors	16.7M	-
7	Display Mode	Transmission mode, normally black	-
8	Viewing Direction	Full viewing	-
9	Display Format	RGB vertical stripe	-
10	Surface Treatment	Anti-Glare	-
11	Interface	MIPI	-
12	Backlight	White LED	-
13	Operation Temperature	-20~70	°C
14	Storage Temperature	-30~80	°C
15	Driver IC	HX8394F	-
16	Weight	-	g



2. MECHANICAL SPECIFICATION

REV	DATE	REVISED	REVISED CAUSE	REVISED	REVISED DESCRIPTIONS

FIELD	TOLERANCES
L<=6.00	±0.05
6.0<L<=18.0	±0.10
L>18.0	±0.15
Angle	1°

	<p>LED CIRCUIT 3*4=12EA, 30mA*4=120mA</p>

REV 版本	PART NO. 产品料号	HG069HS004	
B	客户料号		
SCALE 比例	MATERIAL 材质		
1:1	COLOR 颜色	UNIT 单位	mm
DATE 日期	2019-05-14	APPROVED BY 审核	
		CHECKED BY 绘图	

正 式 图 纸

深圳市鸿光显示有限公司

NOTES:

1. DISPLAY TYPE: 6.86", TFT LCD
2. DISPLAY MODE: Normally black mode
3. VIEWING DIRECTION: ALL 85(TYP)
4. DRIVER IC: (※材料指定)
5. LCM(White):
 Brightness(centre point): X:0.260(MIN) 0.360(MAX);
 Chromaticity(centre point) X:0.280(MIN) 0.380(MAX);
 Y:0.280(MIN) 0.380(MAX);
 Uniformity(9 AVG 1/6) 70%(MIN), 75%(TYP)
6. BACK LIGHT: 12 chip white LEDs IF=30mA/LED Vf=9.0-10.8V
7. OPERATING TEMP: -10° C TO 50° C, STORAGE TEMP: -20° C TO 60° C
8. * Critical Parameter: () ref Parameter, () cpk Parameter
 Unspecified Tolerances: ±0.50mm
 Modification mark: ▲
9. SUGGESTION: TP window size unit lateral increase 0.3-0.5mm than LCM A.A
10. REQUIREMENTS ENVIRONMENTAL PROTECTION: RoHS



3. PIN DESCRIPTION

FPC Connector is used for the module electronics interface.

No.	Symbol	Function	Remark
1	GND	Ground	
2	MIPI-D0P	Positive MIPI differential data input	
3	MIPI-D0N	Negative MIPI differential data input	
4	GND	Ground	
5	MIPI-D1P	Positive MIPI differential data input	
6	MIPI-D1N	Negative MIPI differential data input	
7	GND	Ground	
8	MIPI-CLKP	Positive MIPI differential clock input	
9	MIPI-CLKN	Negative MIPI differential clock input	
10	GND	Ground	
11	MIPI-D2P	Positive MIPI differential data input	
12	MIPI-D2N	Negative MIPI differential data input	
13	GND	Ground	
14	MIPI-D3P	Positive MIPI differential data input	
15	MIPI-D3N	Negative MIPI differential data input	
16	GND	Ground	
17	GND		
18	IOVCC(1.8V)	A power supply for the logic power and I/O circuit.	
19	IOVCC(1.8V)		
20	NC	No connection	
21	NC	No connection	
22	NC	No connection	
23	NC	No connection	
24	RESET(1.8V)	Reset pin.	
25	STBYB(1.8V)	Standby mode control.	
26	AVDD/NC	No connection	
27	GND	Ground	
28	K	LED Cathode	
29	K		
30	GND	Ground	
31	NC	No connection	
32	GND	Ground	
33	GND	Ground	
34	NC	No connection	
35	A	LED Anode	
36	A		
37	GND	Ground	
38	VDD(3.3V)	A power supply for the analog power.	
39	VDD(3.3V)		
40	VCOM/NC	No connection	

4. ELECTRICAL CHARACTERISTICS

4.1 ABSOLUTE MAXIMUM RATINGS

Item	Symbol	Values		Unit	Remark
		Min.	Max.		
Digital Supply Voltage	VCI	-0.3	4.0	V	
Digital Supply Voltage	IOVCC	-0.3	3.0	V	
Supply Voltage	VSP	4.5	6.0	V	
Supply Voltage	VSN	-4.5	-6.0	V	

4.2 TFT LCD MODULE

4.2.1 Operating Conditions

Item	Symbol	Values			Unit	Remark
		Min.	Typ.	Max.		
Digital Supply Voltage	VDD	3.0	3.3	3.6	V	
Digital Supply Voltage	IOVCC	1.6	1.8	2.0	V	
Logic Input Voltage	VIH	0.7VDD	-	VDD	V	
	VIL	GND	-	0.3VDD	V	

Note1: Please adjust VCOM to make the flicker level be minimum

Note2: TYP VCOM is only reference value. It must be optimized according to each LCM. Be sure to use VR and OP buffer on VCOM output. Please adjust VCOM to make the flicker level be minimum for getting excellent image.

4.2.2 Current Consumption

Item	Symbol	Condition	Values			Unit	Remark
			Min.	Typ.	Max.		
Digital Current	IVCI	VDD= 3.3V	-	130	-	mA	Note1
Digital Current	IIOVCC	IOVCC=1.8V	-	20	-	mA	

Note1: Typ. specification: Gray-level test Pattern



4.3 BACKLIGHT UNIT

Item	Symbol	Values			Unit	Remark
		Min.	Typ.	Max.		
LED Current	Iled	-	120	-	mA	Total LED
Forward voltage	VF	9.0	9.9	10.8	V	IF=120mA
Reverse current	IR	-	-	50	μA	VR=5V, 1LED
Power dissipation	Pd	1188			mW	Total LED
Peak forward current	IFP	100			mA	1LED
Reverse Voltage	VR	5			V	1LED

Internal Circuit Diagram

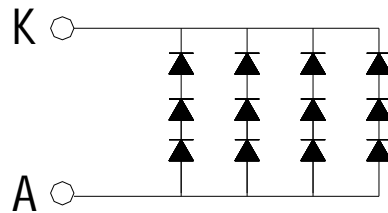

$$3 * 4 = 12 \text{LED} \quad I_F = 30 * 4 = 120 \text{mA}$$



4.4 POWER ON/OFF SEQUENCE

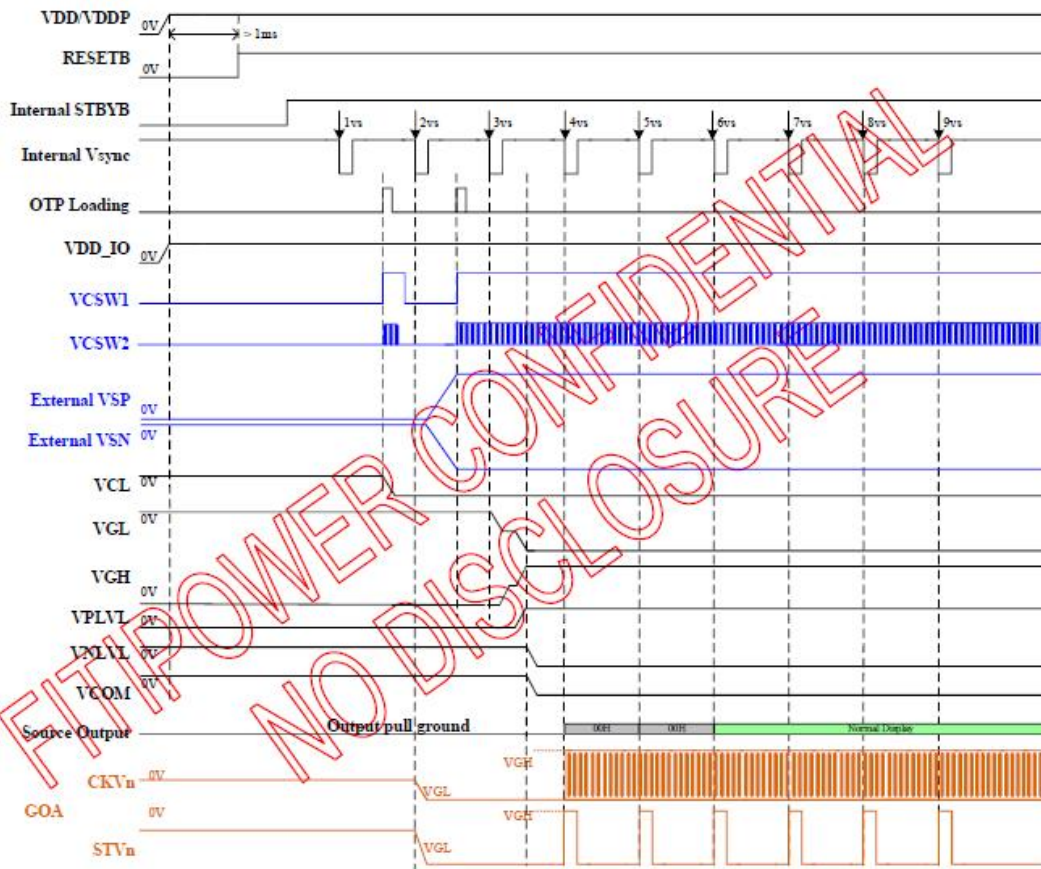



5.INPUT SIGNAL TIMING

5.1 MODE DC ELECTRICAL CHARACTERISTICS

(Test condition: VCI=1.6~3.6V, TA=-20°C~+85°C, VSS=VSSA=0V)

Parameter	Symbol	Spec.			Unit	Note
		Min.	Typ.	Max.		
VDDIO Input high level voltage	VIH	0.8 x VDDIO		VDDIO	V	
VDDIO input low level voltage	VIL	VSS		0.2 x VDDIO	V	
Input Leakage Current	Ileak	(-1)		(+1)	μA	
VGL_REG2 output voltage	VGL_REG2		TBD		V	
VGMP output voltage	VGMP		TBD		V	
VGMN output voltage	VGMN		TBD		V	
VCI1 output voltage	VCI1		TBD		V	
VGL output voltage	VGL_O	-16		-6	V	
VGH output voltage	VGH_O	8		19	V	
VCL output voltage	VCL	-2.1	-2.4	-3	V	
VOM output voltage	VCOM	-2.75	-1.48	-0.2	V	
Input terminal resistance	ZIN		100		ohm	
Source output level deviation	Graycode = 0 ~ 14		TBD		mV	
	Graycode = 241 ~ 255					
	Graycode = 15 ~ 31		TBD		mV	
	Graycode = 208 ~ 240					
Source output offset deviation	Graycode = 32 ~ 207		TBD		mV	
	Graycode = 0 ~ 14	-	TBD		mV	
	Graycode = 241 ~ 255	-				
	Graycode = 15 ~ 31	-	TBD		mV	
Current consumption	Graycode = 208 ~ 240	-				
	Graycode = 32 ~ 207	-	TBD		mV	
	Analog Operating	IAOP	TBD		mA	
	Analog Stand-by	IAST	TBD		mA	
Rush current	Ivddpeak		TBD		mA	
VOTP operation current	Ivpp		TBD		mA	

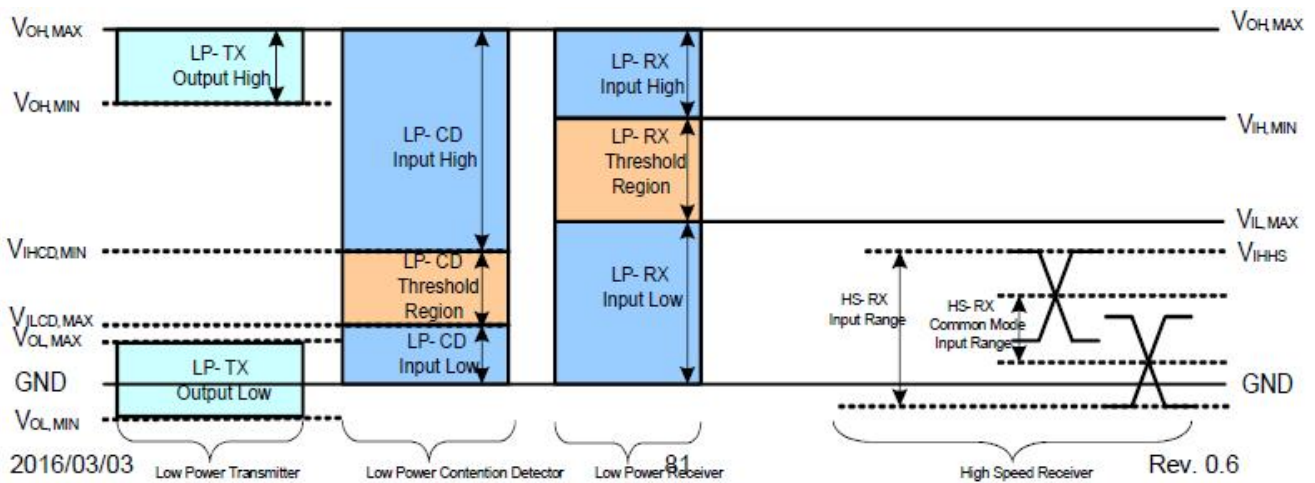



5.2 AC CHARACTERISTICS

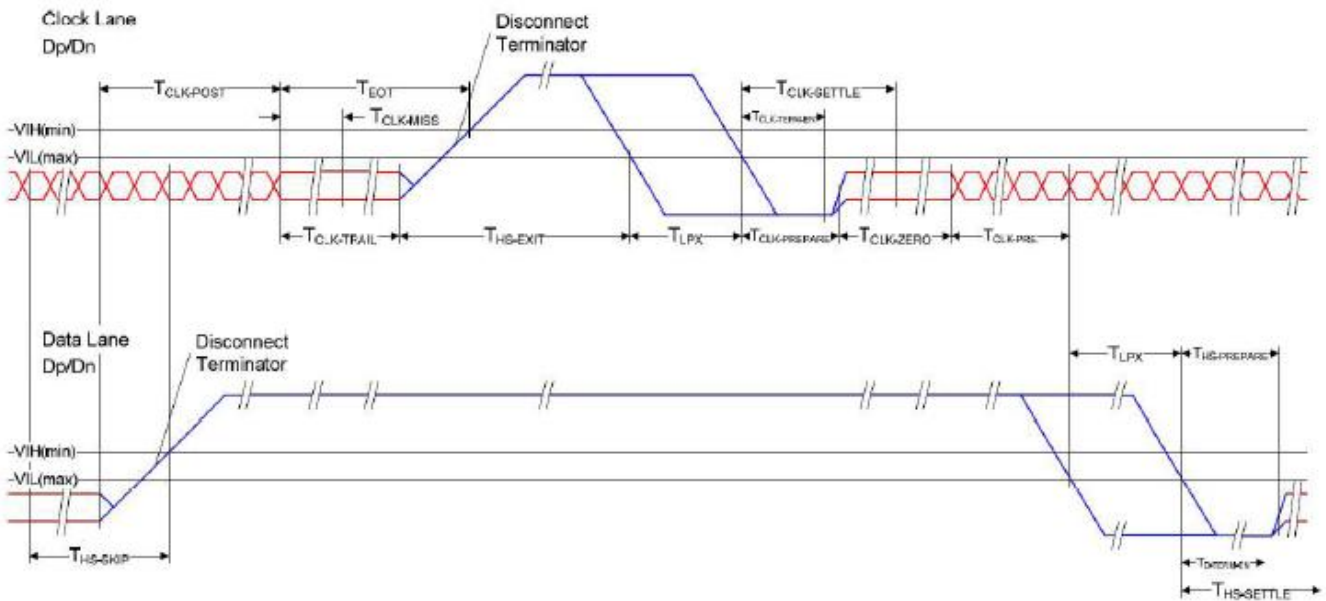

Figure 13.1: Switching the clock lane between clock transmission and low-power mode

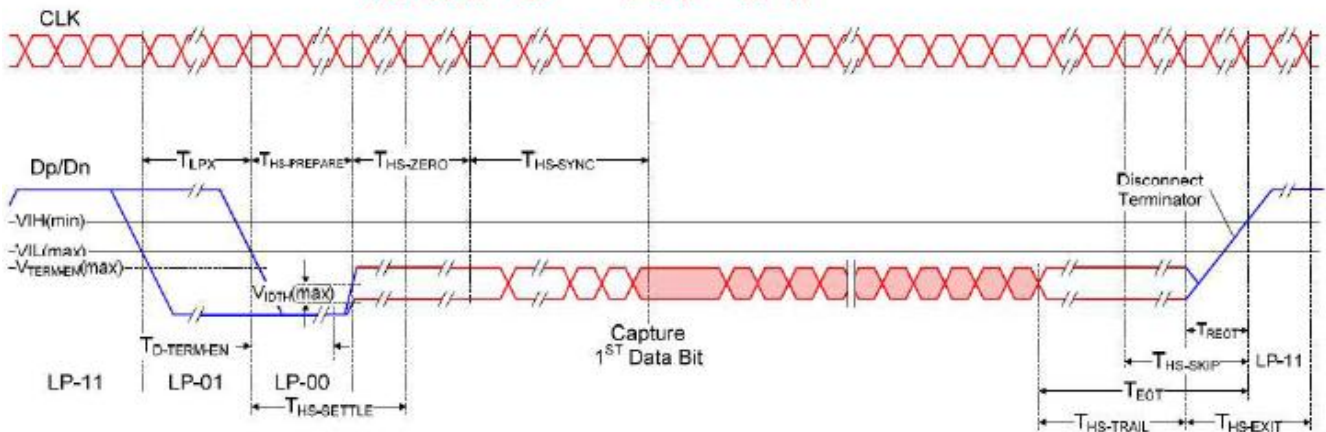

Figure 13.2: Timing of high-speed data transmission in bursts



5.3 PARALLEL RGB INPUT TIMING TABLE

For 480RGBx1280

Parameter	Symbol	Value			Unit
		Min.	Typ.	Max.	
MIPI (4 Lane) @Frame rate=60Hz			386		Mbps
MIPI (3 Lane) @Frame rate=60Hz			515		Mbps
DCLK frequency @Frame rate=60Hz	F _{DCLK}		64.4		MHz
HSYNC period time	T _H		824		DCLK
Horizontal display area	T _{HD}		480		DCLK
HSYNC pulse width	T _{HPW}		24	-	DCLK
HSYNC back porch	T _{HBP}		160	-	DCLK
HSYNC front porch	T _{FBP}		160	-	DCLK
VSYNC period time	T _V		1304		H
Vertical display area	T _{VD}		1280		H
VSYNC pulse width	T _{VPW}		2	-	H
VSYNC back porch	T _{VBP}		10	-	H
VSYNC front porch	T _{VFP}		12	-	H

MIPI Frequency = (Frame rate) x T_H x T_V x 24bits.



6.OPTICAL CHARACTERISTICS

Ta=25±2℃

Item	Symbol	Min.	Typ.	Max.	Unit	Note	
Contrast Ratio	CR	-	500	-		Note1 Note3	
Luminance(center)	L	450	500	-	cd/m ²	Note1 Note5 Note7	
Luminous tolerance	LU	70	75		%	Note7	
Response Time	Rising + Falling	-	30	35	ms	Note1 Note4	
Viewing Angle K=Contrast Ratio>10	Horizontal	θx^+	80	85	-	degr ee	Note2
		θx^-	80	85	-		
	Vertical	θy^+	80	85	-		
		θy^-	80	85	-		
Color Chromaticity (CIE1931)	Red	x	Typ- 0.05	0.623	Typ+ 0.05	Note1 Note5 Note7	
		y		0.331			
	Green	x		0.299			
		y		0.542			
	Blue	x		0.142			
		y		0.076			
	White	x		0.285			
		y		0.304			
Color gamut (NTSC ratio)		55	60		%		

Note1: Definition of optical measurement system (BM-7)

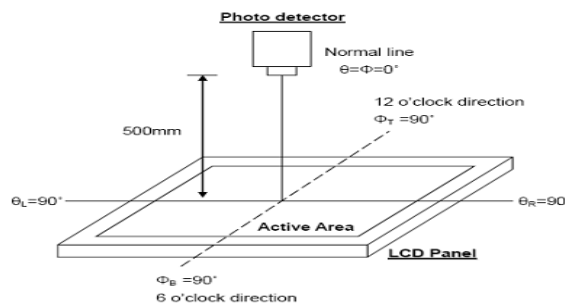

Note2: Definition of viewing angle range and measurement system

Viewing angle is measured at the center point of the LCD by CONOSCOPE (ergo-80).

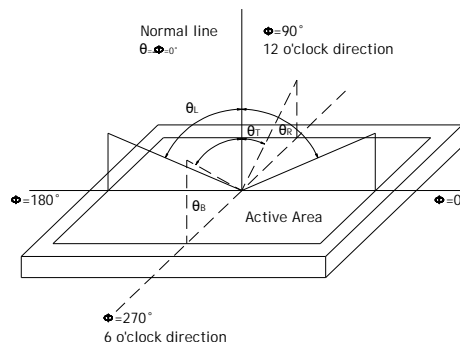

Note3: Definition of Response time



The response time is defined as the LCD optical switching time interval between “White” state and “Black” state. Rise time (TON) is the time between photo detector output intensity changed from 90% to 10%. And fall time (TOFF) is the time between photo detector output intensity changed from 10% to 90%.

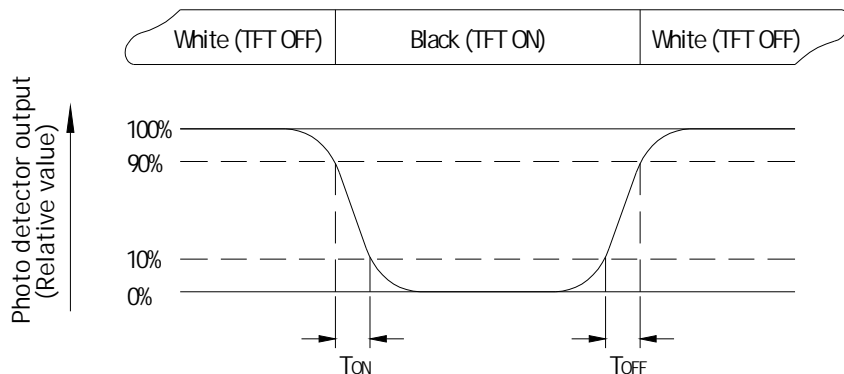

Fig. 6-3 Definition of response time

Note4: Definition of contrast ratio

$$\text{Contrast ratio(CR)} = \frac{\text{Luminance measured when LCD on the Whitestate}}{\text{Luminance measured when LCD on the Blackstate}}$$

“White state “: The state is that the LCD should drive by Vwhite.

“Black state”: The state is that the LCD should drive by Vblack.

Vwhite: To be determined Vblack: To be determined.

Note5: Definition of color chromaticity (CIE1931)

Color coordinates measured at center point of LCD.

Note6: All input terminals LCD panel must be ground while measuring the center area of the panel. The LED driving condition is IL=120mA

Note7: Definition of Luminance Uniformity

Active area is divided into 9 measuring areas. Every measuring point is placed at the center of each measuring area.

$$\text{Luminance Uniformity (U)} = \text{Lmin} / \text{Lmax}$$

L----Active area length, W---- Active area width

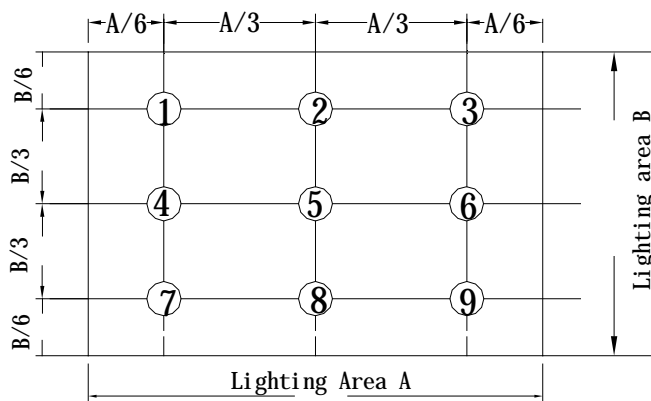

Bmax: The measured maximum luminance of all measurement position.

Bmin: The measured minimum luminance of all measurement position.

7. RELIABILITY TEST ITEMS

7.1 TEMPERATURE AND HUMIDITY

Test Item	Test Condition	Remark
High Temperature Storage	Ta=80°C; 240hrs	IEC60068-2-1: 2007 GB2423.2-2008
Low Temperature Storage	Ta=-30°C;240hrs	IEC60068-2-1: 2007 GB2423.1-2008
High Temperature Operation	Ta=70°C;240Hrs	IEC60068-2-1: 2007 GB2423.2-2008
Low Temperature Operation	Ta=-20°C; 240hrs	IEC60068-2-1: 2007 GB2423.1-2008
High Temperature High Humidity Operation	Ta=60°C, 90%RH, 96Hrs(no condensation)	IEC60068-2-78: 2001 GB/T2423.3-2006
Thermal Shock	-30°C(0.5h) ~ 80°C(0.5h) / 48 cycles	Start with cold temperature , End with high temperature, IEC60068-2-14:1984,GB2423.22-2002
Image Sticking	25°C ; 1hrs	Note1

Note1:Condition of image sticking test :25°C±2°C

Operation with test pattern sustained for 1 hrs,then change to gray pattern immediately.after 5 mins,the mura must be disappeared completely

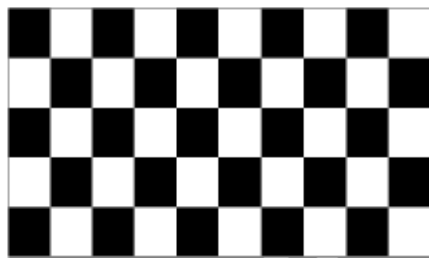

(a) Test Pattern (chess board Pattern)



(b) Gray Pattern

7.2 VIBRATION&SHOCK

Test item	Conditions	Remark
Packing Shock (non-operation)	980m/s ² ,6ms, ±x,y,z 3times for direction	IEC60068-2-27: 1987 GB/T2423.5-1995
Packing Vibration (non-operation)	Frequency range:10 HZ~50HZ Stroke:1.0mm,sweep:10 HZ ~50HZ x,y,z 2 hours for each direction	IEC60068-2-32: 1990 GB/T2423.8-1995

7.3ESD

Test item	Conditions	Remark	
Electro Static Discharge Test (non-operation)	150pF, 330Ω, Contact:±2KV,Air:±4KV	1	Class C
	200pF, 0Ω, ±200V contact test	2	

Note: Measure point :

- LCD glass and metal bezel
- IF connector pins
- ESD class B:some performance degradation allowed. Self-recoverable
No data lost,no hardware failures.



8. GENERAL PRECAUTION

8.1 SAFETY

1. Do not swallow any liquid crystal, even if there is no proof that liquid crystal is poisonous.
2. If the LCD panel breaks, be careful not to get liquid crystal to touch your skin.
3. If skin is exposed to liquid crystal, wash the area thoroughly with alcohol or soap.

8.2 STORAGE CONDITIONS

1. Store the panel or module in a dark place where the temperature is $23\pm 5^{\circ}\text{C}$ and The humidity is below $50\pm 20\%\text{RH}$.
2. Store in anti-static electricity container.
3. Store in clean environment, free from dust, active gas, and solvent.
4. Do not place the module near organics solvents or corrosive gases.
5. Do not crush, shake, or jolt the module.

8.3 HANDLING PRECAUTIONS

1. Avoid static electricity which can damage the CMOS LSI.
2. The polarizing plate of the display is very fragile. So, please handle it very carefully.
3. Do not give external shock.
4. Do not apply excessive force on the surface.
5. Do not wipe the polarizing plate with a dry cloth, as it may easily scratch the Surface of plate.
6. Do not use ketonics solvent & Aromatic solvent, use with a soft cloth soaked with a cleaning naphtha solvent.
7. Do not operate it above the absolute maximum rating.
8. Do not remove the panel or frame from the module.
9. When the module is assembled, it should be attached to the system firmly, Be careful not to twist and bend the module.
10. Wipe off water droplets or oil immediately. If you leave the droplets for a long time, staining and discoloration may occur.
11. If the liquid crystal material leaks from the panel, it should be kept away from the eyes or mouth in case of contact with hands, legs or clothes, it must be washed away thoroughly with soap.

8.4 WARRANTY

1. The period is within twelve months since the date of shipping out under normal using and storage conditions.
2. Do not repaired or modified the LCM. It may cause function to lose efficacy, Starry does not warrant the LCM.
3. All process and material comply ROHS.



9. INSPECTION STANDARDS

9.1 Incoming inspection right

(1) The Incoming Inspection Standard will be agreed and signed by both sides(Customer an starry)

9.2 Inspection condition is as follows

- (1) Viewing distance is approximately 35~40 cm
- (2) Viewing angle is normal to the LCD panel as Fig-1(30°)
- (3) Ambient temperature is approximately $25 \pm 5^{\circ}\text{C}$
- (4) Ambient humidity is $60 \pm 5\% \text{RH}$
- (5) Ambient illuminance is from 300~500 Lux
- (6) Input signal timing should be typical value
- (7) Mura & Light leakage inspection an ND-Filter 5%

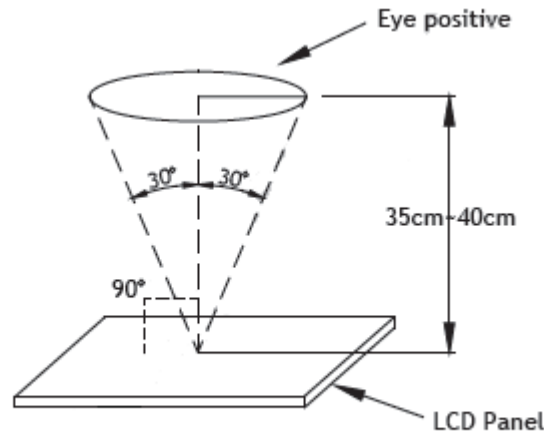

Fig-1

9.3 Special condtion

- (1) Viewing distance is close for inspection of adjacent dots and distance between defect Dots
- (2) Viewing condition of “ Shot block non-uniformity from oblique angle”is as Fig-2
- (3) Exceptional case:Veiw angle $\pm 40^{\circ}$ while inspected image-sticking

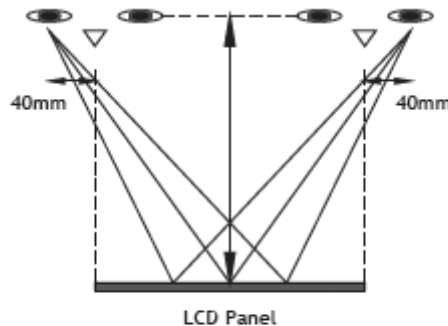

Fig-2



9.4 INSPECTION CRITERIA

Defecttype		Limit			Note	
Visual defect	Scratch	$W \leq 0.05\text{mm}$		Ignore	Note1	
		$0.05\text{mm} \leq w \leq 0.1\text{m}$		$N \leq 3$		
		$L \leq 10\text{mm}$				
		$20\text{mm} < l, 0.1\text{mm} < w$		$N=0$		
	Internal	Spot	$\Phi < 0.3\text{mm}$		Ignore	Note 1
			$0.3\text{mm} \leq \varphi \leq 0.4\text{mm}$		$N \leq 3$	
			$0.4 \leq \varphi$		$N=0$	
		Fiber	$0.1\text{mm} \leq w \leq 0.2\text{m}$		$N \leq 4$	Note 1
			$L \leq 2.5\text{mm}$			
		Polarizer bubble	$0.2\text{mm} < w, 2.5\text{mm} < l$		$N=0$	Note 1
			$\Phi < 0.3\text{mm}$		Ignore	
			$0.25\text{mm} \leq \varphi \leq 0.5\text{mm}$		$N \leq 2$	
		Dent	$0.5 \leq \varphi$		$N=0$	Note 1
			$\Phi < 0.25\text{mm}$		Ignore	
			$0.25\text{mm} \leq \varphi \leq 0.5\text{mm}$		$N \leq 4$	
Electrical Defect	Bright dot	C area	O area	Total	Note 2 Note 3	
		$N \leq 1$	$N \leq 2$	$N \leq 3$		
	Dark dot	$N \leq 2$	$N \leq 4$	$N \leq 4$	use of ND5 % invisible OK	
	Total dot	$N \leq 3$	$N \leq 4$	$N \leq 4$		
Dense point	Using ND5 % visible by intensive foreign standard judgement, ND5 % invisible OK			Note 4		

- (1) One pixel consists of 3 sub-pixel, including r, g, and b dot. (sub-pixel=dot)
 (2) Panel is acceptable if distance between 2 dot defects are greater or equal to 5mm.



Note1 : W : Width[mm], L : Length[mm], N : Number, ϕ : Average Diameter

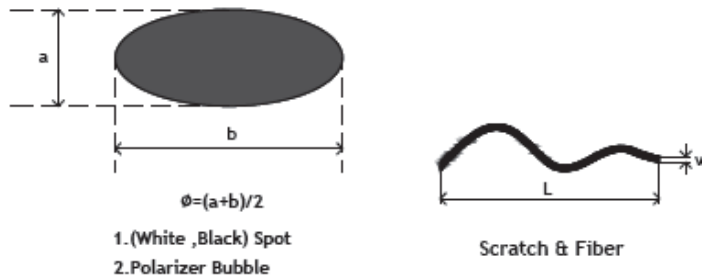

Note2 : Bright dot is defined as the defective area of the dot is larger than 50% of one sub-pixel area.

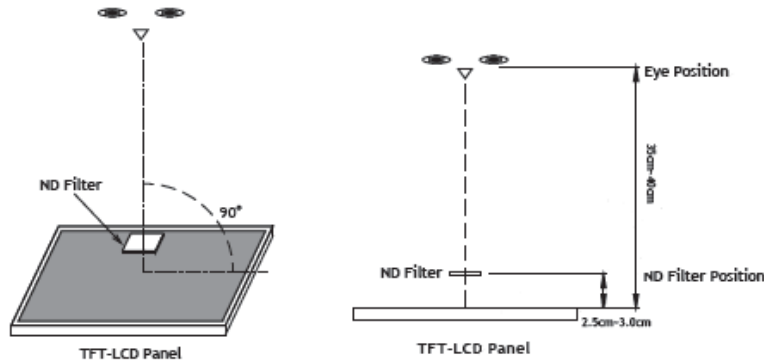

Note3 :

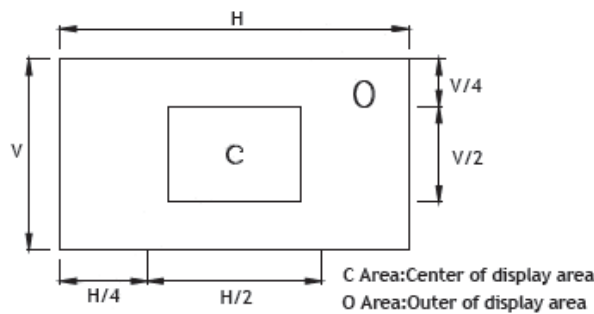

Note4 : Judge defect dot and adjacent dot as following. Allow below (as A, B, C and D status) adjacent defect dots, including bright and dart adjacent dot. And they will be counted 2 defect dots in total quantity.

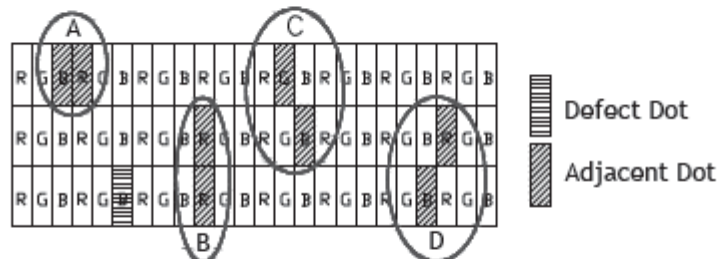

Note5 : Other condition

- (1) The defects that are not defined above and considered to be problem shall be reviewed and discussed by both parties.
- (2) Defects on the Black Matrix, out of Display area, are not considered as a defect or counted.



10. PACKAGE DRAWING

