



SPECIFICATION FOR TFT LCD MODULE

CUSTOMER : _____

CUSTOMER MODULE : _____

HG MODEL : HG070WS012

Preliminary Specification

Final Specification

Customer Confirmation column:

Approved by : _____ Dept. : _____ Data : _____

Please return one of the copies of the specification with your signature to us within two weeks after you receive this document. If it is not returned, we will assume that you agree to the entire contents of this specification document.

Designed by	Checked by	Approved by



REVISION STATUS

Version	Revise Date	Page	Content	Modified by
V1.0	2019.07.11	-	First Issued.	



TABLE OF CONTENTS

No.	CONTENTS	PAGE
	REVISION STATUS.....	2
	TABLE OF CONTENTS.....	3
1.	GENERAL DESCRIPTION.....	4
2.	MECHANICAL SPECIFICATION.....	4
3.	PIN DESCRIPTION.....	5
4.	ELECTRICAL CHARACTERISTICS.....	7
5.	INPUT SIGNAL TIMING.....	10
6.	OPTICAL CHARACTERISTICS.....	13
7.	RELIABILITY TEST ITEMS.....	16
8.	GENERAL PRECAUTION.....	17
9.	PACKAGE DRAWING.....	18



1. GENERAL DESCRIPTION

1.1 Introduction

The Display model HG070WS012 is a color active matrix thin film Transistor (TFT) liquid crystal display (LCD) that uses amorphous silicon TFT as a switching device. This model is composed of a TFT LCD panel, a driving circuit and a back light system. This TFT LCD has a 7(16:9) inch diagonally measured active display area with WSVGA (1024 horizontal by 600 vertical pixel) Resolution.

1.2 Features

7 inch (16:9 diagonal) configuration

- 16.7M color by 6 bit + Hi-FRC input
- RoHS/Halogen Free Compliance

1.3 Applications

Automotive

1.4 TFT LCD General information

Item		Specification	Unit
Outline Dimension		164.9x100.0 (typ)	mm
Display area		153.6(H) x 86.64(V)	mm
Number of pixel		1024 RGB (H) x 600(V)	pixels
Pixel pitch		0.150 (H) x 0.1444(V)	mm
Pixel arrangement		RGB Vertical stripe	
Display mode		Normally white	
NTSC		50 (typ.)	%
Surface treatment		Anti-glare with EWV Film	
Weight		(146)g (Typ.)	g
Back-light		White LED	
Power Consumption	Logic	0.5(Max) @ Black pattern .Frame rate 60Hz	W
	BL System	2.3(typ) @ Black pattern w/o LED driver	W

1.5 Mechanical information

Item		Min.	Typ.	Max.	unit
Module size	Horizontal(H)	164.6	164.9	165.2	mm
	Vertical(V)	99.7	100	100.3	mm
	Depth(D)	---	5.5	5.8	mm
weight		----	(TBD)	---	g



2. MECHANICAL SPECIFICATION

1

2

3

4

5

6

7

8

1 DIMENSION RANGE 尺寸范围

MAXIMUM RANGE (±)	A	B	C	D	E	F	G	H	I	J	K	L	M	N	O	P	Q	R	S	T	U	V	W	X	Y	Z
0	0.05	0.10	0.15	0.20	0.25	0.30	0.35	0.40	0.45	0.50	0.55	0.60	0.65	0.70	0.75	0.80	0.85	0.90	0.95	1.00	1.05	1.10	1.15	1.20	1.25	1.30

公差以上表所示，除非另有约定

2 Customers Name: 客户名称

3 Approval Date: 承认日期

4 Approved by: 承认

5 Please Confirm This Drawing On Before 请在此图前确认

模组图

NO.	定义	NO.	定义
1	VCOM	21	RXIN3+
2	VDD	22	GND
3	VDD	23	NC
4	NC	24	NC
5	RESET	25	GND
6	STBYB	26	NC
7	GND	27	DIND
8	RXIND-	28	SELB
9	RXIND+	29	AVDD
10	GND	30	GND
11	RXINT-	31	LED-
12	RXINT+	32	LED-
13	GND	33	L/R
14	RXIN2-	34	U/D
15	RXIN2+	35	VGL
16	GND	36	GND
17	RXCLKIN-	37	GND
18	RXCLKIN+	38	VGH
19	GND	39	LED+
20	RXIN3-	40	LED+

3 Approval Date: 承认日期

4 Approved by: 承认

5 Please Confirm This Drawing On Before 请在此图前确认

模组图

NO.	定义	NO.	定义
1	VCOM	21	RXIN3+
2	VDD	22	GND
3	VDD	23	NC
4	NC	24	NC
5	RESET	25	GND
6	STBYB	26	NC
7	GND	27	DIND
8	RXIND-	28	SELB
9	RXIND+	29	AVDD
10	GND	30	GND
11	RXINT-	31	LED-
12	RXINT+	32	LED-
13	GND	33	L/R
14	RXIN2-	34	U/D
15	RXIN2+	35	VGL
16	GND	36	GND
17	RXCLKIN-	37	GND
18	RXCLKIN+	38	VGH
19	GND	39	LED+
20	RXIN3-	40	LED+

主要材料表

10	F00	1
9	Bezel	1
8	Reflector film	1
7	Prism film (upper)	1
6	Prism film (lower)	1
5	Diffuser film	1
4	SMT LED (white)	27
3	FPC	1
2	Light guide	1
1	Plastic housing	1

测试点位置图

光源

线路原理图

试做图

REV 版本: A0

MATERIAL 客户料号: *****

SCALE 比例: 1:1

COLOR 颜色: 164.9*100*5.5

UNIT 单位: mm

DATE 日期: 2020-09-04

SHENZHEN HONGGUANG DISPLAY CO., LTD

1

2

3

4

5

6

7

8

Hongguang Display

HG070WS012

5 / 26



3. PIN DESCRIPTION

TFT LCD Module: FPC UP Connector, (FH28-40S-0.5SH (HIROSE), 40pin,pitch = 0.5mm)

Pin No.	Symbol	Function	Remark
1	VCOM	Common voltage	
2-3	VDD	Power Voltage for digital circuit	
4	NC	No connection	
5	Reset	Global reset pin	
6	STBYB	Standby mode. Normally pulled high STBYB="1", normal operation STBYB="0" timing controller, source driver will turn off ,all output are High-Z	
7	GND	Digital ground	
8	RXIN0-	-LVDS differential data input	
9	RXIN0+	+LVDS differential data input	
10	GND	Digital ground	
11	RXIN1-	-LVDS differential data input	
12	RXIN1+	+LVDS differential data input	
13	GND	Digital ground	
14	RXIN2-	-LVDS differential data input	
15	RXIN2+	+LVDS differential data input	
16	GND	Digital ground	
17	RXCLKIN-	-LVDS Clock data input	
18	RXCLKIN+	+LVDS Clock data input	
19	GND	Digital ground	
20	RXIN3-	-LVDS differential data input	
21	RXIN3+	+LVDS differential data input	
22	GND	Digital ground	
23	NC	No connection	
24	NC	No connection	
25	GND	Digital ground	
26	NC	No connection	
27	NC	No connection	
28	SELB	6 bit/8 bit mode select	Note 1
29	AVDD	Power for Analog Circuit	
30	GND	Digital ground	
31-32	LED-	LED Cathode	
33	L/R	Horizontal inversion	Note 2
34	U/D	Vertical inversion	Note 2
35	VGL	Gate OFF Voltage	
36-37	NC	No connection	
38	VGH	Gate ON Voltage	



39-40	LED+	LED Anode	
-------	------	-----------	--

Note 1: If LVDS input data is 6 bits, SELB must be set to High;

If LVDS input data is 8 bits, SELB must be set to Low;

Note 2: When L/R="0", set right to left scan direction.

When L/R="1", set left to right scan direction.

When U/D="0" set top to bottom scan direction.

When U/D="1" set bottom to top scan direction.

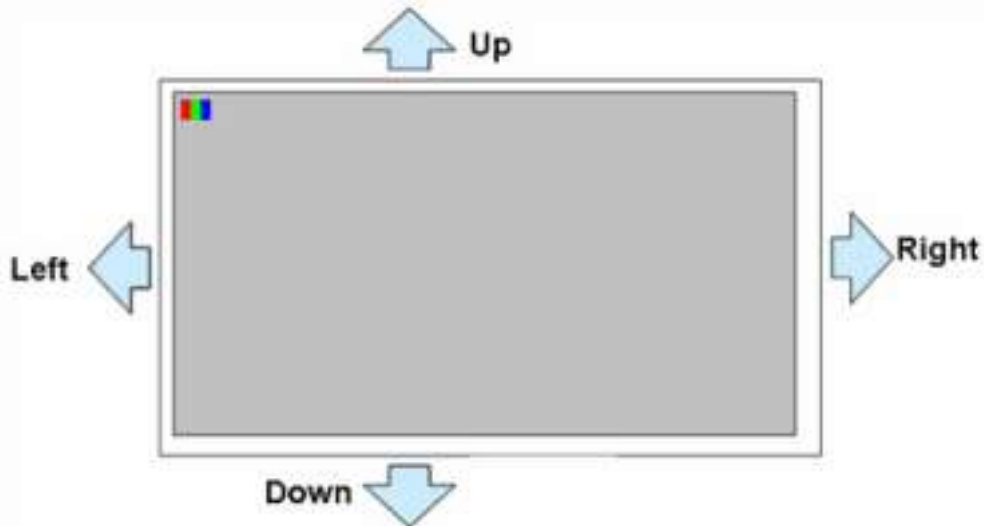

4. ELECTRICAL CHARACTERISTICS

4.1 ABSOLUTE MAXIMUM RATINGS

Item	Symbol	Min.	Max.	Unit
Digital Supply Voltage	VDD	-0.3	5.0	V
Analog supply voltage	AVDD	-0.3	15	V
Gate on voltage	VGH	-0.3	25	V
Gate off voltage	VHL	-20	0.3	V

4.2 TFT LCD MODULE

4.2.1 OPERATING CONDITIONS

Parameter	Symbol	Min.	Typ.	Max.	Unit
Digital Supply Voltage	VDD	3.0	3.3	3.6	V
TFT Gate ON Voltage	VGH	17.7	18	18.3	A
TFT Gate OFF Voltage	VHL	-10.3	-10	-9.7	W
TFT Common electrode voltage	VCOM	2.9	3.2	3.8	A
Analog Power Supply voltage	AVDD	9.2	9.5	10.0	V
Back light Powe	V	8	9.6	10.6	V

NOTE

TYP VCOM is only reference value. It must be optimized according to each LCM.



Be sure to use VR and OP buffer on VCOM output. Please adjust VCOM to make the flicker level be minimum for getting excellent image.

4.3 Switching Characteristics for LVDS Receiver

Symbol	Item	Min.	Typ.	Max.	Unit	Remark
IVGH	Gate on current	--	0.36-	--	mA	VGH=18V
IVGL	Gate OFF current	--	1.0-	--	mA	VGL=-6.8V
IVDD	Digital Current	--	33	--	mA	VDD=1.8
IAVDD	Analog Power Supply voltage	--	19	--	mA	AVDD=9.6V
IVCOM	TFT Common electrode voltage	--	0.001	--	mA	VCOM=3.2V

4.4 BACK LIGHT UNIT

Ta=25°C

Item	Symbol	Min.	Typ.	Max.	Unit	Remark
LED current	ILED		200		mA	Total LED
Forward voltage	VF	8.4	9.6	10.5	V	IF=200mA
Reverse current	IR			50	μA	VR=5V, 1LED
Power dissipation	Pd	2520			mW	Total LED
Peak forward current	IFP	150			mA	1LED
Reverse Voltage	VR	5			V	1LED

线路原理图

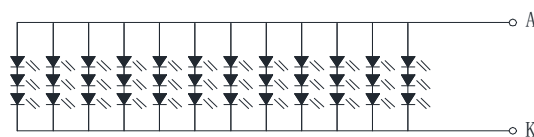

LED: 3C*9P=27PCS, 9.6V, 200MA



● **Absolute Maximum Ratings(Ta=25°C)**

Parameter	Symbol	Rating	Unit
Power Dissipation	Pd	200	mW
Forward Current	If	60	mA
Peak Forward Current*1	I _{IF}	120	mA
Reverse Voltage	V _R	5	V
Operating Temperature	T _{opr}	-40°C~100°C	-
Storage Temperature	T _{stg}	-40°C~100°C	-
Soldering Temperature	T _{sol}	See Page 9	-

*1 Condition for I_{IF} is pulse of 1/10 duty and 3 msec width.

● **Electrical and optical characteristics(Ta=25°C)**

Parameter	Symbol	Condition	Min.	Typ.	Max.	Unit
Forward Voltage	V _f	IF=60mA	2.8	2.9	3.0	V
Luminous Intensity	I _v	IF=60mA	20	22	25	LM
Chromaticity Coordinates	X	IF=60mA	0.263	-	0.265	--
	Y		0.245	-	0.250	--
color temperature	TC	IF=60mA	-	25000	-	K
Viewing Angle	2θ 1/2	IF=60mA	--	120	--	deg.



● Typical Electro-Optical Characteristics Curves

Fig.1 RELATIVE INTENSITY VS WAVELENGTH

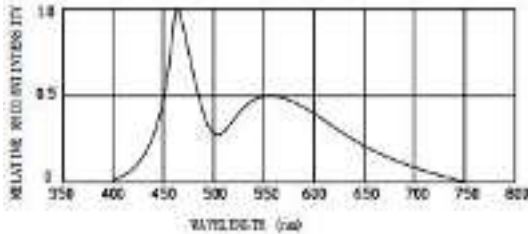

Fig.2 FORWARD CURRENT VS AMBIENT TEMPERATURE

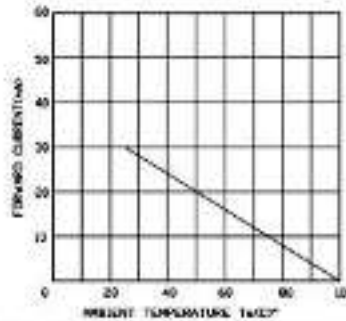

Fig.3 FORWARD CURRENT VS FORWARD VOLTAGE

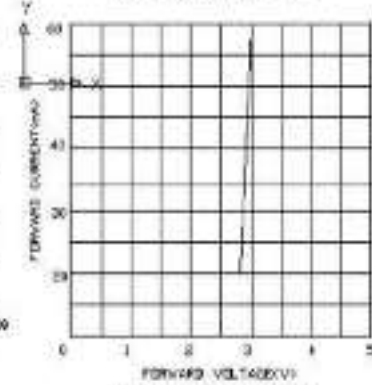

Fig.4 RELATIVE LUMINOUS INTENSITY VS AMBIENT TEMPERATURE

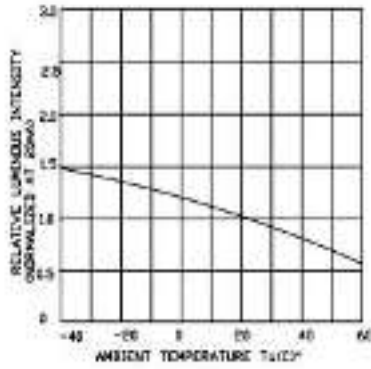

Fig.5 RELATIVE LUMINOUS INTENSITY VS FORWARD CURRENT

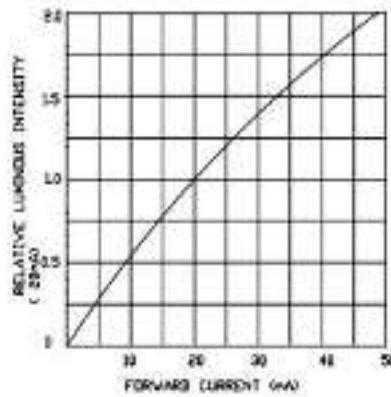

Fig.6 RADIATION DIAGRAM

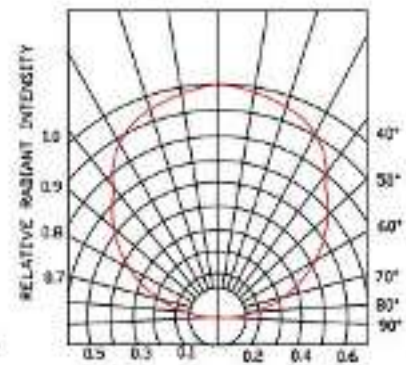

Fig.7 FORWARD CURRENT VS CHROMATICITY COORDINATE

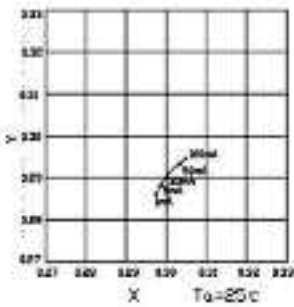
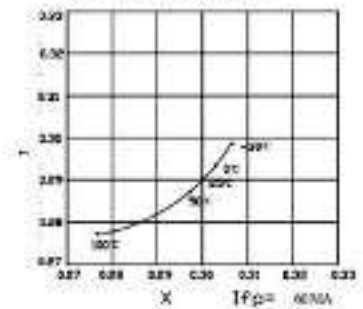

Fig.8 AMBIENT TEMPERATURE VS CHROMATICITY COORDINATE





4.5 POWER ON/OFF SEQUENCE

Power-On/Off Timing Sequence:

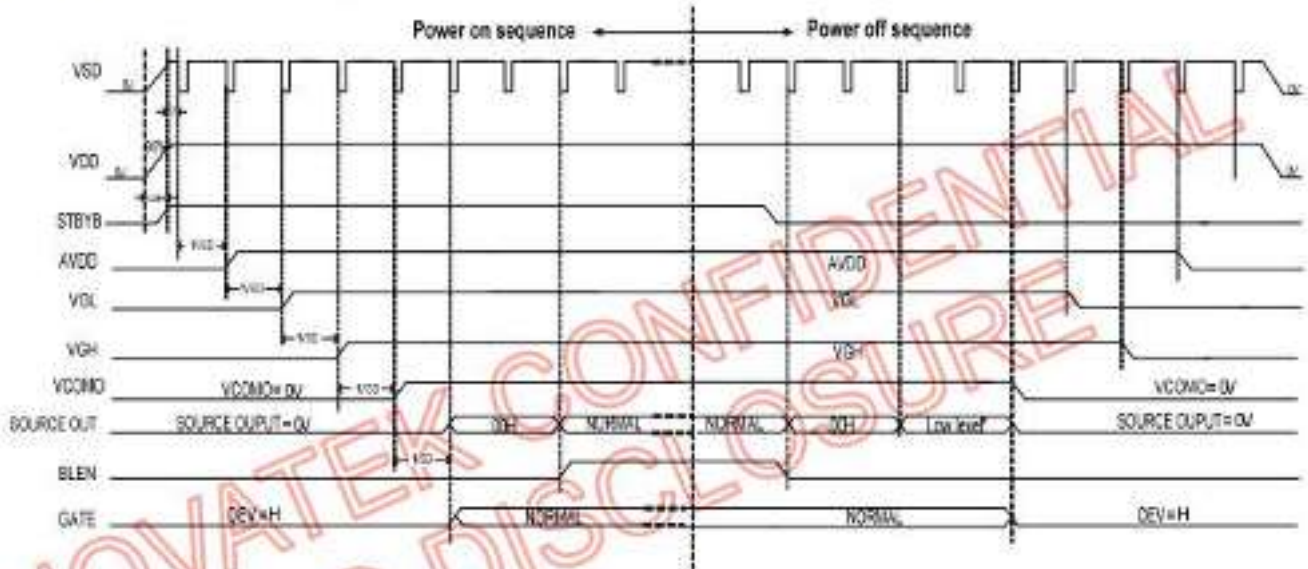

Enter and Exit Standby Mode Sequence:

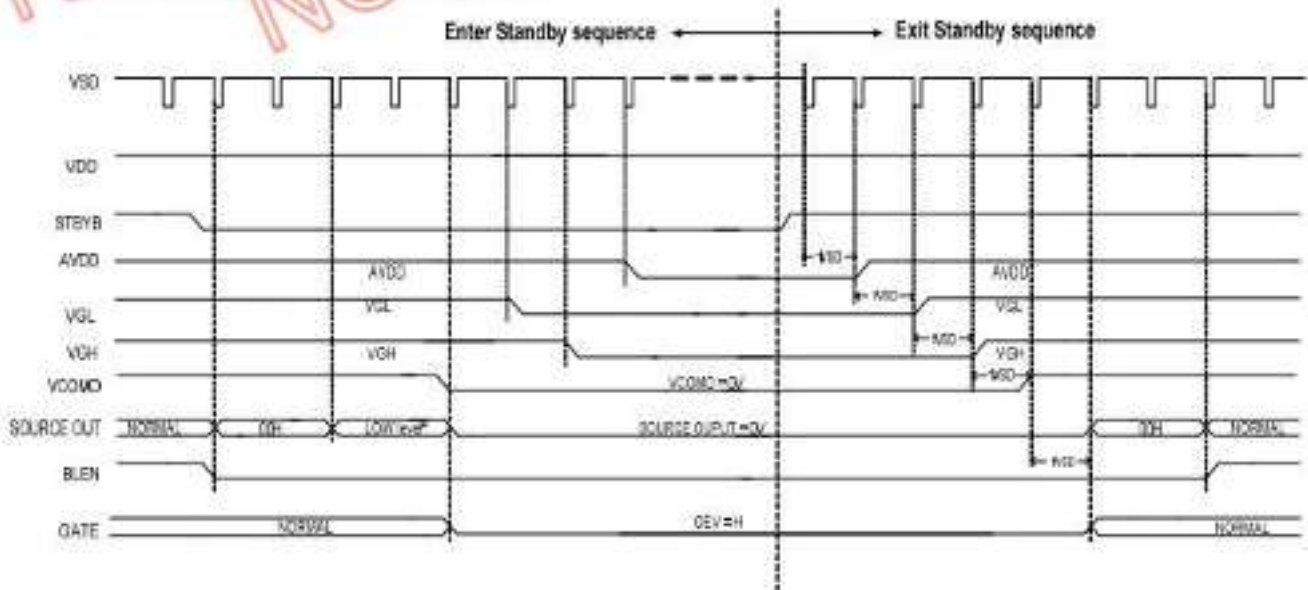

*Note : Low level = 3FH , when NBW = L (Normally white)



5.INPUT SIGNAL TIMING.

5.1 LVDS mode DC electrical characteristics

Parameter	Symbol	Spec.			Unit	Condition
		Min.	Typ.	Max.		
Differential input high Threshold voltage	R_{XVTH}	-	-	+0.1	V	$R_{XVCM}=1.2V$
Differential input low threshold voltage	R_{XVTL}	-0.1	-	-	V	
Input voltage range (singled-end)	R_{XVIN}	0	-	$VDD-1.2+$ $ V_{ID} /2$	V	-
Differential input common Mode voltage	R_{XVCM}	$ V_{ID} /2$	-	$VDD-1.2$	V	-
Differential input voltage	$ V_{ID} $	0.2	-	0.6	V	-
Differential input leakage Current	$R_{V_{ILe}}$	-10	-	+10	μA	-
LVDS Digital Operating Current	I_{ddlvds}	-	15	30	mA	Fclk=65MHz, VDD=3.3V
LVDS Digital Stand-by Current	I_{stlvds}	-	10	50	μA	Clock & all Functions are stopped

Table 9.3: LVDS mode DC electrical characteristics

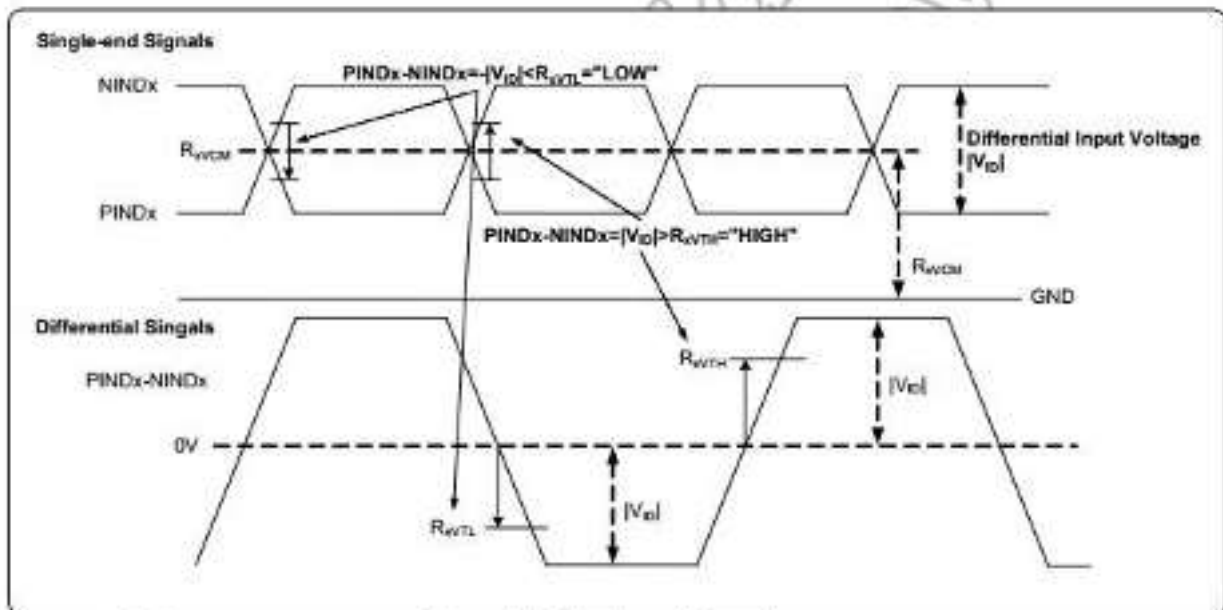

Figure 9.1: Single-end signals



5.2 AC CHARACTERISTICS

LVDS mode

Parameter	Symbol	Min.	Typ.	Max.	Unit	Condition
Clock frequency	R_{sFCLK}	20		71	MHz	
Input data skew margin	T_{RSKM}	500			pS	$ V_{ID} = 400mV$ $R_{AVCM} = 1.2V$ $R_{sFCLK} = 71 MHz$
Clock high time	T_{LVCH}		$4/(7 * R_{sFCLK})$		ns	
Clock low time	T_{LVCL}		$3/(7 * R_{sFCLK})$		ns	
PLL wake-up time	T_{wPLL}			150	μS	

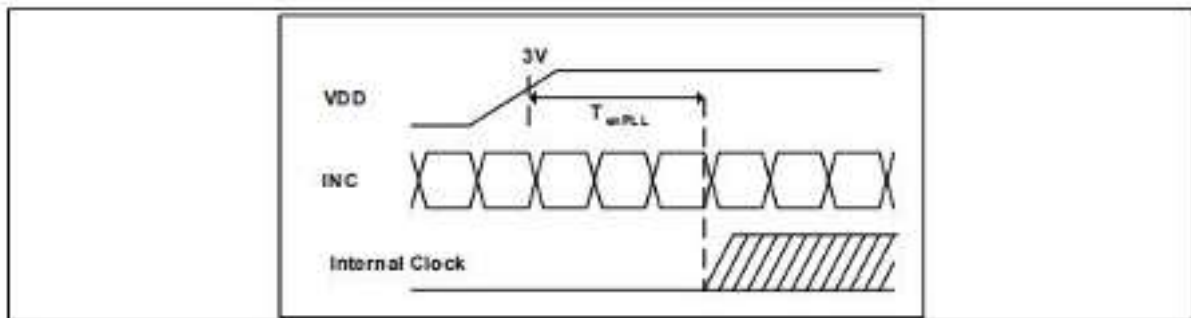
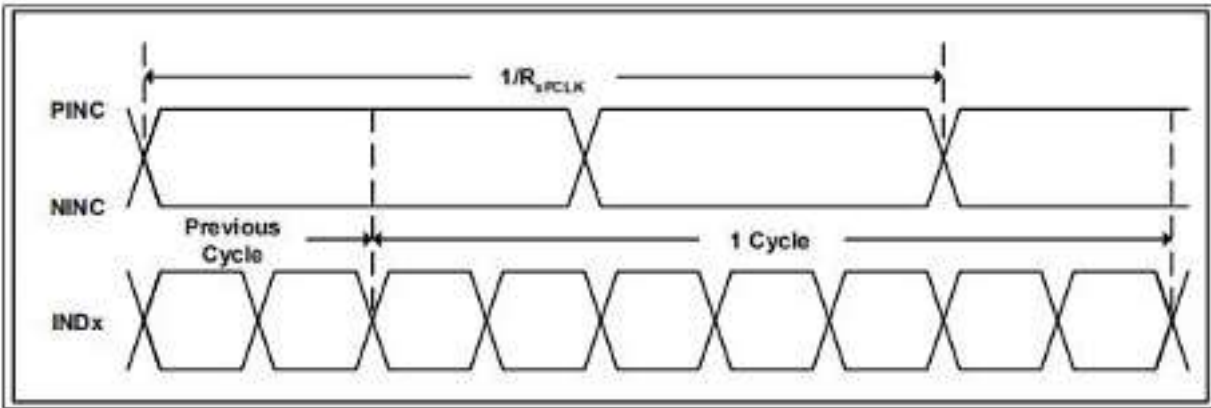



Output Timing Table

Parameter	Symbol	Min.	Typ.	Max.	Unit	Conditions
DCLK Frequency	Fclk	-	65	71	MHz	VDD = 2.3V ~3.6V
DCLK Cycle Time	Tclk	14.1	15.4	-	ns	
DCLK Pulse Duty	Tcwh	40	50	60	%	Tclk
Time from HSD to Source Output	Thso	-	64	-	DCLK	
Time from HSD to LD	Thld	-	64	-	DCLK	
Time from HSD to STV	Thstv	-	2	-	DCLK	
Time from HSD to CKV	Thckv	-	20	-	DCLK	
Time from HSD to OEV	Thoev	-	4	-	DCLK	
LD Pulse Width	Twld	-	10	-	DCLK	
CKV Pulse Width	Twckv	-	66	-	DCLK	
OEV Pulse Width	Twoev	-	74	-	DCLK	



5.3 Bit LVDS INPUT

5.3.1 6bit LVDS input (SELB="1")

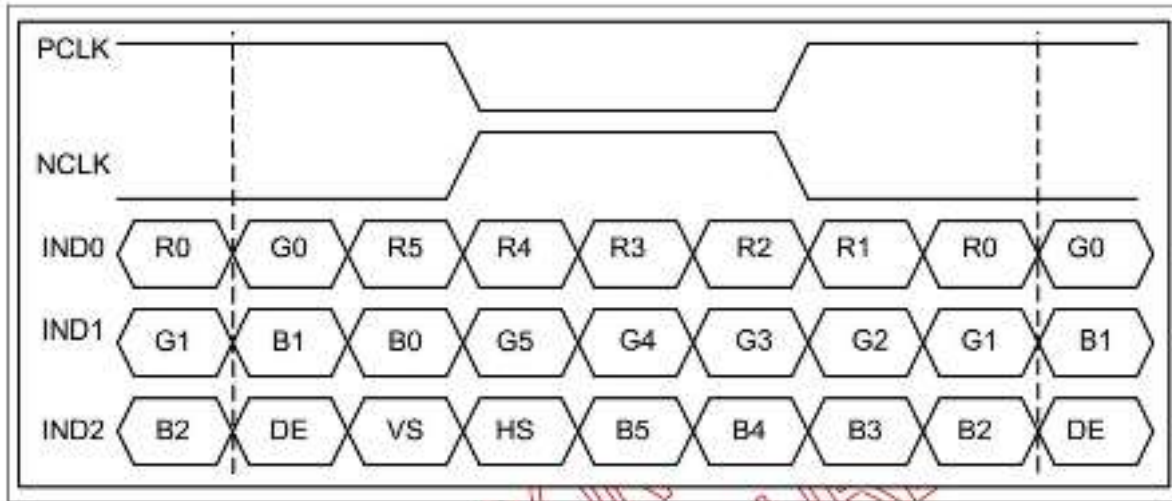

5.3.1 8BIT LVDS INPUT (SELB="0")

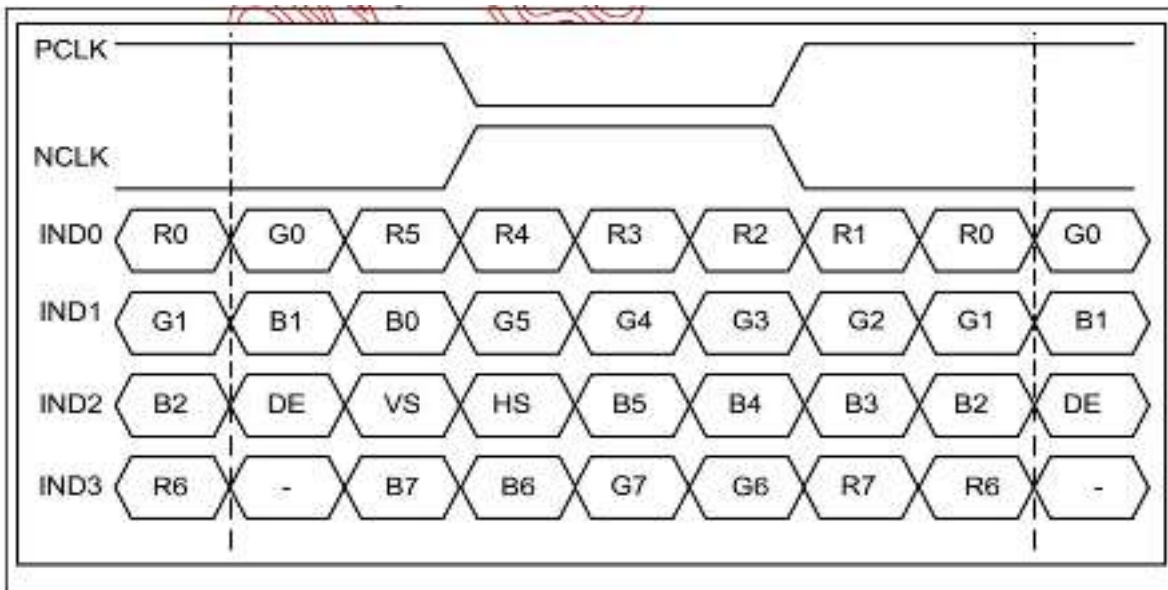



5.4 INTERFACE TIMING

DE mode

Parameter	Symbol	Value			Unit
		Min.	Typ.	Max.	
DCLK frequency @ Frame rate = 60Hz	fclk	40.8	51.2	67.2	MHz
Horizontal display area	thd	1024			DCLK
HSYNC period time	th	1114	1344	1400	DCLK
HSYNC blanking	thb+thfp	90	320	376	DCLK
Vertical display area	tvd	600			H
VSYNC period time	tv	610	635	800	H
VSYNC blanking	tvb+tvfp	10	35	200	H

HV mode

Horizontal input timing

Parameter		Symbol	Value			Unit
Horizontal display area		thd	1024			DCLK
DCLK frequency @ Frame rate = 60Hz		fclk	Min.	Typ.	Max.	MHz
			44.9	51.2	63	
1 Horizontal Line		th	1200	1344	1400	DCLK
HSYNC pulse width	Min.	thpw	1			
	Typ.		-			
	Max.		140			
HSYNC blanking		thb	160	160	160	DCLK
HSYNC front porch		thfp	16	160	216	

Vertical input timing

Parameter	Symbol	Value			Unit
		Min.	Typ.	Max.	
Vertical display area	tvd	600			H
VSYNC period time	tv	624	635	750	H
VSYNC pulse width	tvpw	1	-	20	H
VSYNC Blanking (tvb)	tvb	23	23	23	H
VSYNC Front porch (tvfp)	tvfp	1	12	127	H



Timing Diagram

1. Input Clock and Data Timing Diagram

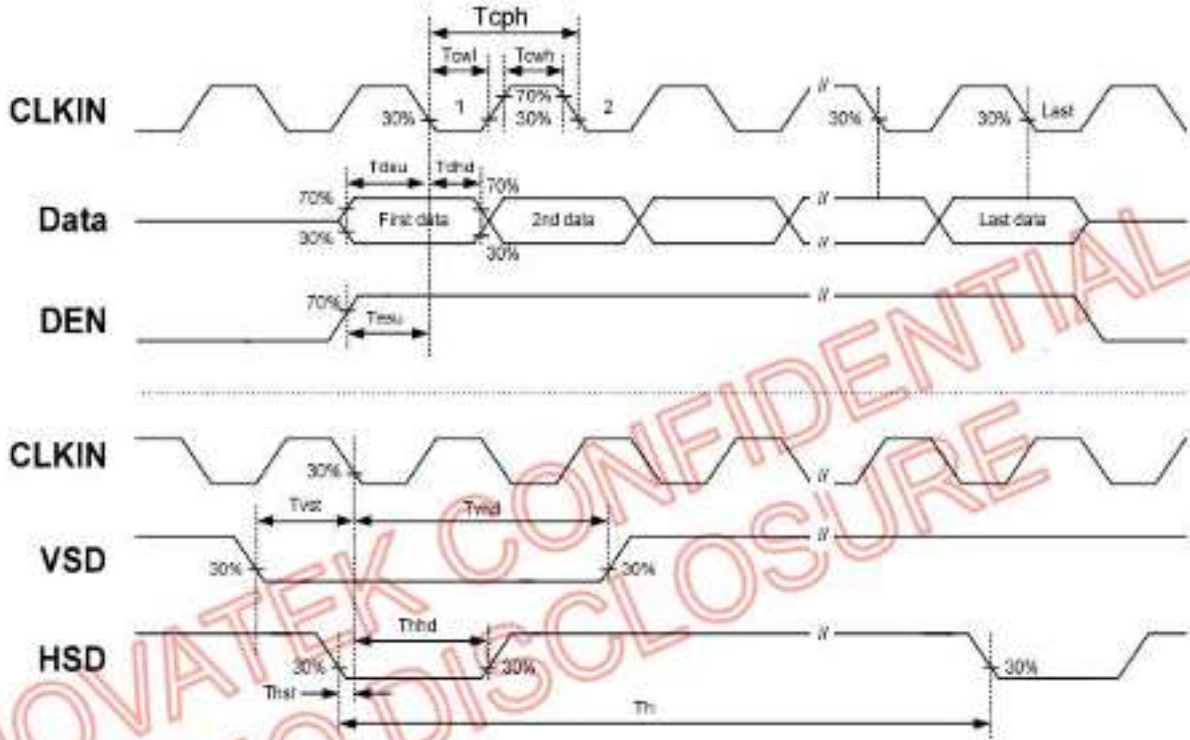

2. Source Output Timing Diagram (Cascade)

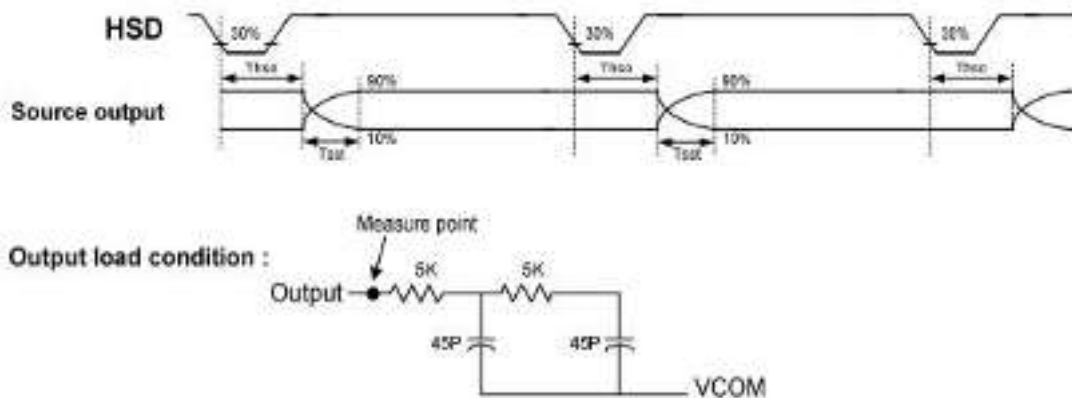



6.OPTICAL CHARACTERISTICS

Ta=25±2℃

Item	Symbol	Min.	Typ.	Max.	Unit	Note	
Contrast Ratio	CR	-	800	-		Note1 Note3	
Luminance(center)	L	500	550	600	cd/m2	Note1 Note5 Note7	
Luminous tolerance	LU	70	75		%	Note7	
Response Time	Rising + Falling	-	30	35	ms	Note1 Note4	
Viewing Angle K=Contrast Ratio>10	Horizontal	θ_{x^+}	70	80	-	degree	Note2
		θ_{x^-}	70	80	-		
	Vertical	θ_{y^+}	60	70	-		
		θ_{y^-}	70	80	-		
Color Chromaticity (CIE1931)	Red	x	Typ- 0.05	0.617	Typ+ 0.05	Note1 Note5 Note7	
		y		0.327			
	Green	x		0.332			
		y		0.600			
	Blue	x		0.146			
		y		0.056			
	White	x		0.299			
		y		0.331			
Color gamut (NTSC ratio)			50		%		
Optima View Direction	6 o'clock						

Note1: Definition of optical measurement system (BM-7)

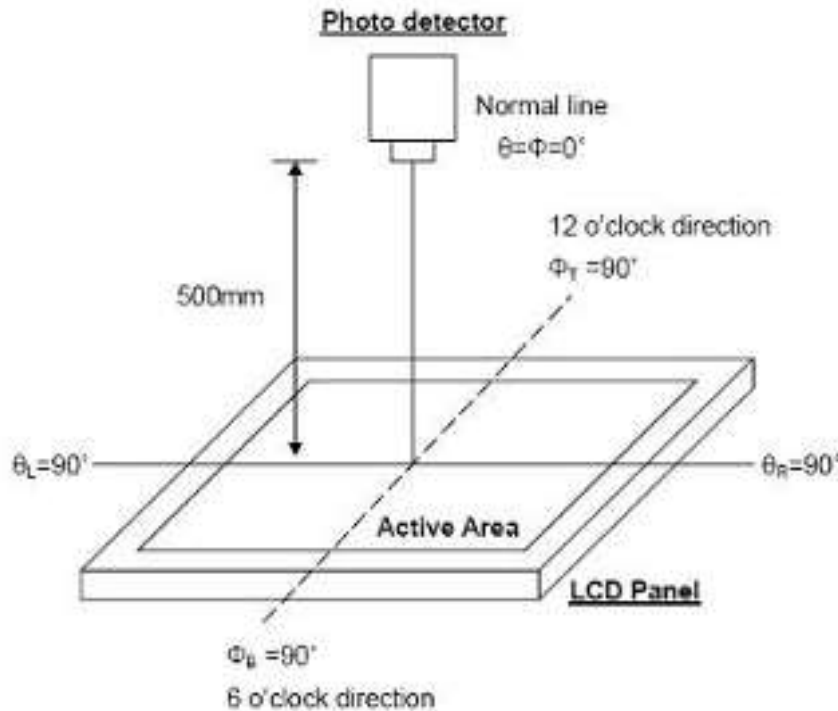

Note2: Definition of viewing angle range and measurement system

Viewing angle is measured at the center point of the LCD by CONOSCOPE (ergo-80).

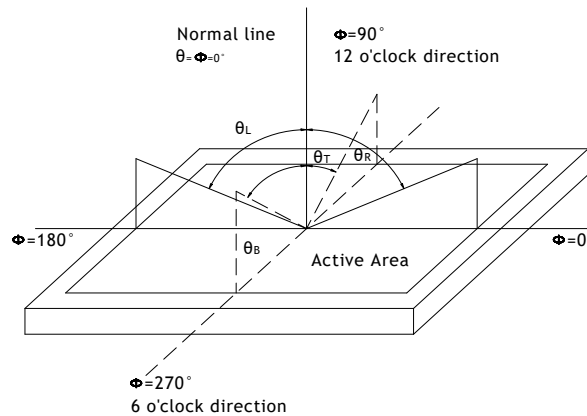

Note3: Definition of Response time

The response time is defined as the LCD optical switching time interval between "White" state and "Black" state. Rise time (TON) is the time between photo detector output intensity changed from 90% to 10%. And fall time (TOFF) is the time between photo detector output intensity changed from 10% to 90%.

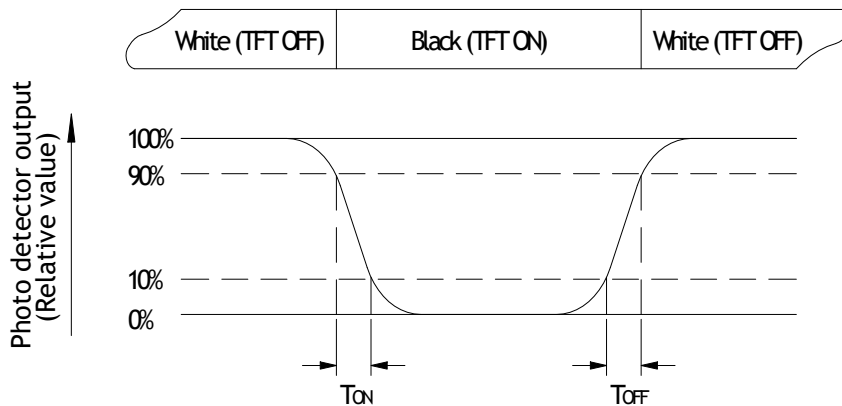

Fig. 6-3 Definition of response time

Note4: Definition of contrast ratio

Contrast ratio(CR)=错误！未找到引用源。

“White state “: The state is that the LCD should drive by V_{white} .

“Black state”: The state is that the LCD should drive by V_{black} .

V_{white} : To be determined V_{black} : To be determined.

Note5: Definition of color chromaticity (CIE1931)

Color coordinates measured at center point of LCD.

Note6: All input terminals LCD panel must be ground while measuring the center area of the panel. The LED driving condition is $I_L=260mA$

Note7: Definition of Luminance Uniformity

Active area is divided into 9 measuring areas. Every measuring point is placed at the center of each measuring area.

Luminance Uniformity (U) = L_{min} / L_{max}

L----Active area length, W---- Active area width

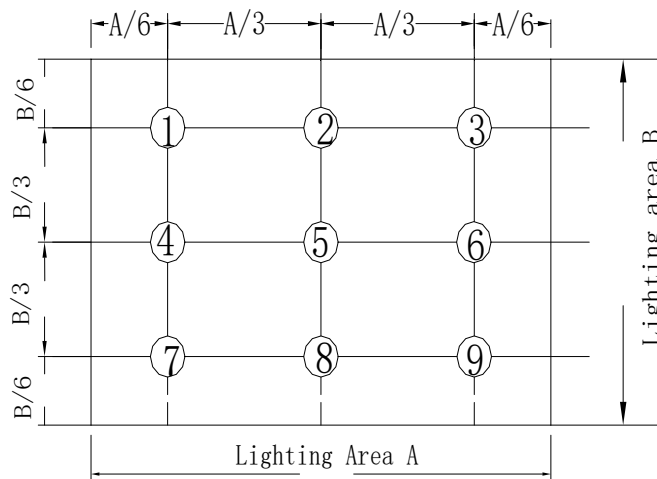

B_{max} : The measured maximum luminance of all measurement position.

B_{min} : The measured minimum luminance of all measurement position.



7.RELIABILITY TEST ITEMS

7.1 TEMPERATURE AND HUMIDITY

Test Item	Test Condition	Remark
High Temperature Storage	Ta=85°C; 240hrs	IEC60068-2-1: 2007 GB2423.2-2008
Low Temperature Storage	Ta=-30°C;240hrs	IEC60068-2-1: 2007 GB2423.1-2008
High Temperature Operation	Ta=85°C, 240Hrs	IEC60068-2-1: 2007 GB2423.2-2008
Low Temperature Operation	Ta=-30°C; 240hrs	IEC60068-2-1: 2007 GB2423.1-2008
High Temperature High Humidity Operation	Ta=60°C, 240%RH, 24Hrs(no condensation)	IEC60068-2-78: 2001 GB/T2423.3-2006
Thermal Shock	-30°C(0.5h) ~85°C(0.5h) / 100 cycles	Start with cold temperature , End with high temperature, IEC60068-2-14:1984,GB2423.22-2002
Image Sticking	25°C ; 1hrs	Note1

Note1:Condition of image sticking test :25°C±2°C

Operation with test pattern sustained for 1hrs,then change to gray pattern immediately.after 15 mins,the mura must be disappeared completely

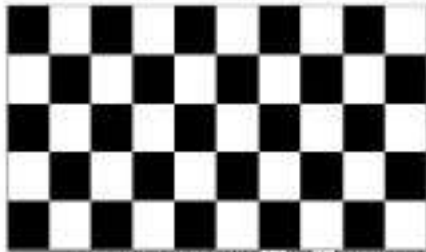

(a) Test Pattern (chess board Pattern)



(b) Gray Pattern

7.2 VIBRATION&SHOCK

Test item	Conditions	Remark
Packing Shock (non-operation)	980m/s ² ,6ms, ±x,y,z 3times for direction	IEC60068-2-27: 1987 GB/T2423.5-1995
Packing Vibration (non-operation)	Frequency range:10 HZ-50HZ Stroke:1.0mm,sweep:10 HZ ~50HZ x,y,z 2 hours for each direction	IEC60068-2-32: 1990 GB/T2423.8-1995

7.3ESD

Test item	Conditions	Remark	
Electro Static Discharge Test (non-operation)	150pF, 330Ω, Contact:±4KV,Air:±8KV	1	Class C
	200pF, 0Ω, ±200V contact test	2	

Note: Measure point :

1. LCD glass and metal bezel
2. IF connector pins



3. ESD class C: To allow a temporary loss of function, the equipment to be measured may stop working but should be able to automatic or manual intervention reset back to normal after operation.

8. GENERAL PRECAUTION

8.1 SAFETY

1. Do not swallow any liquid crystal, even if there is no proof that liquid crystal is poisonous.
2. If the LCD panel breaks, be careful not to get liquid crystal to touch your skin.
3. If skin is exposed to liquid crystal, wash the area thoroughly with alcohol or soap.

8.2 STORAGE CONDITIONS

1. Store the panel or module in a dark place where the temperature is $23 \pm 5^{\circ}$ C and The humidity is below $50 \pm 20\%$ RH.
2. Store in anti-static electricity container.
3. Store in clean environment, free from dust, active gas, and solvent.
4. Do not place the module near organics solvents or corrosive gases.
5. Do not crush, shake, or jolt the module.

8.3 HANDLING PRECAUTIONS

1. Avoid static electricity which can damage the CMOS LSI.
2. The polarizing plate of the display is very fragile. So, please handle it very carefully.
3. Do not give external shock.
4. Do not apply excessive force on the surface.
5. Do not wipe the polarizing plate with a dry cloth, as it may easily scratch the Surface of plate.
6. Do not use ketonics solvent & Aromatic solvent, use with a soft cloth soaked with a cleaning naphtha solvent.
7. Do not operate it above the absolute maximum rating.
8. Do not remove the panel or frame from the module.
9. When the module is assembled, it should be attached to the system firmly, Be careful not to twist and bend the module.
10. Wipe off water droplets or oil immediately. If you leave the droplets for a long time, staining and discoloration may occur.
11. If the liquid crystal material leaks from the panel, it should be kept away from the eyes or mouth in case of contact with hands, legs or clothes, it must be washed away thoroughly with soap.

8.4 WARRANTY

1. The period is within twelve months since the date of shipping out under normal using and storage conditions.
2. Do not repaired or modified the LCM. It may cause function to lose efficacy, Starry does not warrant the LCM.
3. All process and material comply ROHS.



9. PACKAGE DRAWING

Packing form

LCM Model	LCM Qty. in the box	Inner Box Size (mm)	Notice
HG070WS012	60 pcs/box	435±5 x 350±5 x 135±5	

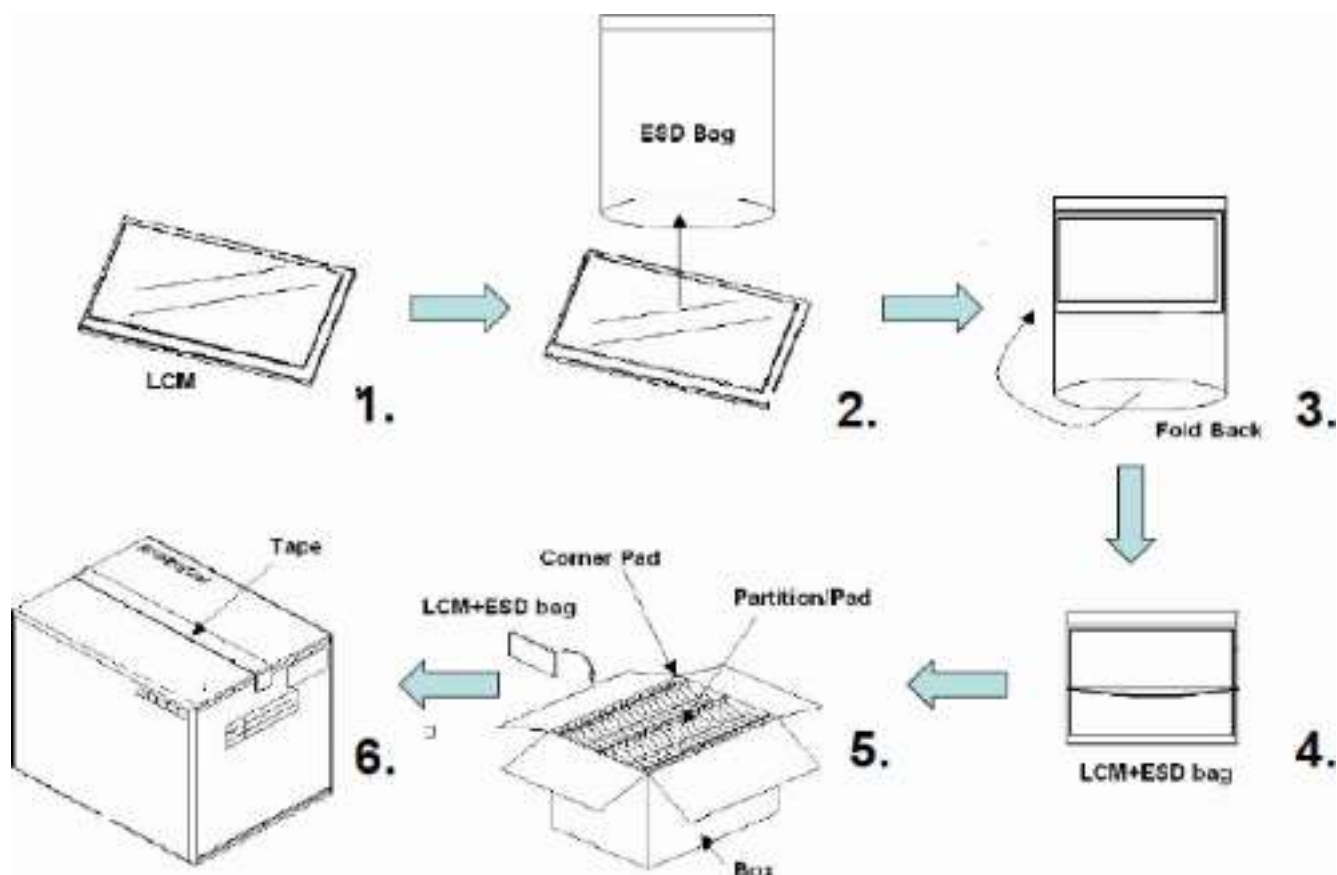



Items	Material	Notice
Box	Corrugated Paper Board	AB Flute
Partition/Pad	Corrugated Paper Board	B Flute
Corner Pad	Corrugated Paper Board	AB Flute
ESD bag	PE	



4. INSPECTION CRITERIA

Defecttype		Limit			Note	
Visual defect	Scratch	$W \leq 0.05\text{mm}$		Ignore	Note1	
		$0.05\text{mm} \leq w \leq 0.1\text{m}$		$N \leq 3$		
		$L \leq 10\text{mm}$				
		$20\text{mm} < l, 0.1\text{mm} < w$		$N=0$		
	Internal	Spot	$\Phi < 0.2\text{mm}$		Ignore	Note 1
			$0.2\text{mm} \leq \varphi \leq 0.4\text{mm}$		$N \leq 3$	
			$0.4 \leq \varphi$		$N=0$	
		Fiber	$0.1\text{mm} \leq w \leq 0.2\text{m}$		$N \leq 4$	Note 1
			$L \leq 2.5\text{mm}$			
		Polarizer bubble	$0.2\text{mm} < w, 2.5\text{mm} < l$		$N=0$	Note 1
			$\Phi < 0.3\text{mm}$		Ignore	
			$0.25\text{mm} \leq \varphi \leq 0.5\text{mm}$		$N \leq 2$	
		Dent	$0.5 \leq \varphi$		$N=0$	Note 1
$\Phi < 0.25\text{mm}$			Ignore			
$0.25\text{mm} \leq \varphi \leq 0.5\text{mm}$			$N \leq 4$			
Electrical Defect	Bright dot	C area	O area	Total	Note 2 Note 3	
		$N \leq 1$	$N \leq 2$	$N \leq 3$		
	Dark dot	$N \leq 2$	$N \leq 4$	$N \leq 4$	use of ND5 % invisible OK	
	Total dot	$N \leq 3$	$N \leq 4$	$N \leq 4$		



	<p>Dense point</p>	<p>Using ND5 % visible by intensive foreign standard judgement, ND5 % invisible OK</p> <div style="display: flex; justify-content: space-around; align-items: center;">   </div>	<p>Note 4</p>
<p>(1) One pixel consists of 3 sub-pixel, including r, g, and b dot. (sub-pixel=dot) (2) Panel is acceptable if distance between 2 dot defects are greater or equal to 5mm.</p>			

Note1 : W : Width[mm], L : Length[mm], N : Number, ϕ : Average Diameter

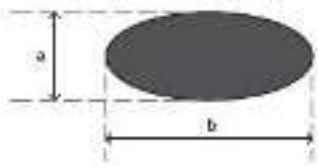

$\phi = (a+b)/2$
 1. (White ,Black) Spot
 2. Polarizer Bubble



Scratch & Fiber

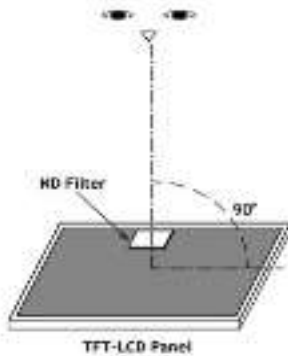

TFT-LCD Panel

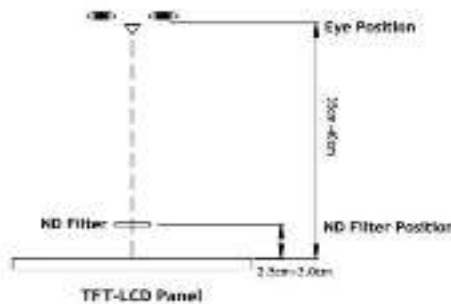

TFT-LCD Panel

Note3 :

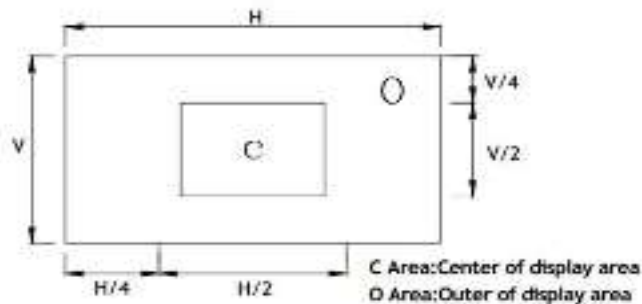

C Area: Center of display area
 D Area: Outer of display area



Note4 : Judge defect dot and adjacent dot as following. Allow below (as A, B, C and D status) adjacent defect dots, including bright and dark adjacent dot. And they will be counted 2 defect dots in total quantity.

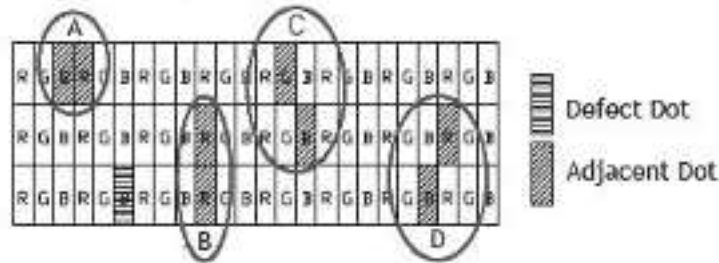

Note5 : Other condition

- (1) The defects that are not defined above and considered to be problem shall be reviewed and discussed by both parties.
- (2) Defects on the Black Matrix, out of Display area, are not considered as a defect or counted.

5. HANDLING PRECAUTION

- (1) Don't disassemble and reassemble the module by self
(禁止自行拆解)
- (2) Acid, alkali, alcohol or touched directly by hand will damage the display.
(酸性、碱性、酒精或手的直接接触将会损伤显示面)
- (3) Static electricity will damage the module. Please configure grounding device.
(静电会损伤模组, 请装配接地设备)
- (4) The strong vibration, shock, twist or bend will cause material damage, even module broken.
(强烈的撞击、震动、扭转或弯曲将会造成原材损伤, 甚至面板破裂)
- (5) It is easy to cause image sticking while displaying the same pattern for very long time.
(长期显示同一画面会造成影像残留)
- (6) The response time, brightness and performance will vary from different temperature.
(响应时间、亮度与均匀性会因温度而有所改变)
- (8) The Period within 12 months since the date of shipping out under normal using And Storage conditions.
(从出货之日开始,在正常使用和存储条件下,产品保质期为12个月)