



SPECIFICATION FOR TFT LCD MODULE

CUSTOMER : _____

CUSTOMER MODULE : _____

HL MODEL : HG070WS045

Preliminary Specification

Final Specification

Customer Confirmation column:

Approved by : _____ Dept. : _____ Data : _____

Please return one of the copies of the specification with your signature to us within two weeks after you receive this document. If it is not returned, we will assume that you agree to the entire contents of this specification document.

Designed by	Checked by	Approved by



Revision History

Version NO.	DATE	Description	Remak
V1.0	2018.11.17	FIRST ISSUE	



Contents

1	Introduction-----	4
2	General specification-----	5
3	Mechanical drawing-----	6
4	Absolute maximum ratings-----	7
5	Electrical characteristics-----	7
6	Optical characteristics -----	7
7	Pin Assignment -----	10
8	LCM quality criteria-----	11



1. Introduction

1.1 Scope of application

This specification applies to the Negative type TFT transmissive dot matrix LCD module that is supplied by HG. This LCD module should be designed for mobile Tablet pc Computer tv use. LCD specification: ALL, Dots 1024xRGBx600. As to basic specification of the driver IC, refer to the IC(TBD) specification and datasheet.

1.2 Structure:

Double display structure:
TFT Module + FPC + BL
FULL Color 7.0 inch TFT LCD size for main LCD;
One bare chip with gold bump (COG) ;
24-bits bus interface;

1.3 TFT features:

Structure: TFT PANNEL+IC+FPC;
Transmissive Type LCD
1024 dot-source and 600 dot-gate outputs;
FULL Color;
White LED back light;

1.4 Applications:

Mobile phone,MP5; PC Computer,TV

1.5 This module uses ROHS material



2. General specification

ITEM	Standard value	UNIT
LCD Type	TFT Negative Transmissive	---
Driver element	a-Si TFT Active matrix	
Number of Dots	1024*(RGB)*600	Dots
Pixel Arrangement	RGB Vertical Stripe	
Pixel Pitch (W*H)	0.1506(W)x0.1432(H)	
Display Area	154.2144(H) x 85.92(V)	mm
Viewing Direction	ALL	
Module Size(W*H*T)	165(W) × 100(H) × 3.25(T)	mm
Approx. Weight	TBD	g
Back Light	White LED	
Data transfer	LVDS	



3. Mechanical drawing

由 Autodesk 教育版产品制作

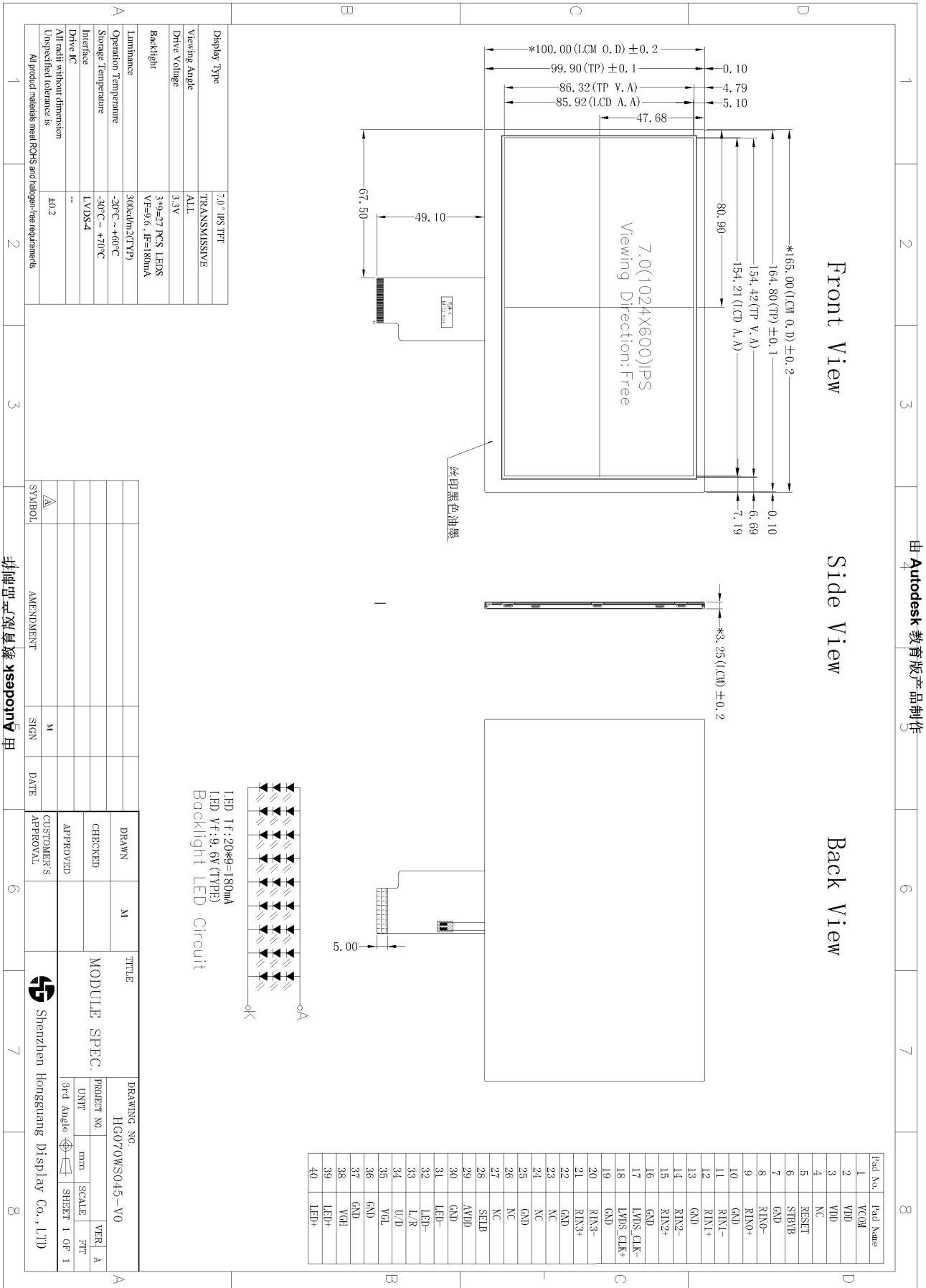



4. ABSOLUTE MAXIMUM RATINGS

Parameter	Symbol	Min	Max	Unit
Supply voltage for logic	V_{DD}	-0.3	3.0	V
Input voltage for logic	V_{IN}	-0.5	$V_{DD} + 0.3$	V
Supply current (One LED)	I_{LED}		20	mA
Operating temperature	T_{OP}	-20	+60	°C
Storage temperature	T_{ST}	-30	+70	°C

5. ELECTRICAL CHARACTERISTICS

Item	Symbol	Min	Typ	Max	Unit	Applicable terminal
Supply voltage for logic	V_{DD}	2.8	3.3	3.5	V	V_{DD}
Input voltage	V_{IL}	-0.3	-	$0.2 V_{DD}$	V	
	V_{IH}	$0.8 V_{DD}$	-	V_{DD}	V	
Input leakage current	I_{LKG}				μA	
AVDD current		9.2	9.6	10	V	
VGH current		15	17	19	V	
VGL current		-7	-6	-5	V	
VCOM current			3.3		V	
LED Forward voltage	V_f	8.6	9.6	10.1	V	--
Input backlight current	I_{LED}		180		mA	With One LED



6. OPTICAL CHARACTERISTICS

ITEM	SYMBOL	CONDITIONS	SPECIFICATION			UNIT	NOTE	
			MIN	TYP.	MAX			
Brightness	B	Viewing normal angle	270	300	--	Cd/m ²	All left side data are based on LEAD's product reference only	
Contrast Ratio	CR		500	800	--	--		
Response Time	Tr+Tf		--	25	40	ms		
CIE Color coordinate	Red		X _R	--	0.571			
			Y _R		0.352			
	Green		X _G	--	0.345			
			Y _G		0.557			
	Blue		X _B	--	0.148			
			Y _B		0.128			
	White		X _w	--	0.314			
		Y _w		0.334				
Viewing Angle	Hor.	θ_{x+}	40	45	--	Deg.		
		θ_{x-}	40	45	--			
	Ver.	θ_{y+}	40	45	--			
		θ_{y-}	40	45	--			
Uniformity	Un		80	85		%		



HV mode

Horizontal input timing

Parameter		Symbol	Value			Unit
Horizontal display area		thd	1024			DCLK
DCLK frequency @ Frame rate = 60Hz		fclk	Min.	Typ.	Max.	MHz
			44.9	51.2	63	
1 Horizontal Line		th	1200	1344	1400	DCLK
HSYNC pulse width	Min.	thpw	1			
	Typ.		-			
	Max.		140			
HSYNC blanking		thb	160	160	160	
HSYNC front porch		thfp	16	160	216	

Vertical input timing

Parameter	Symbol	Value			Unit
		Min.	Typ.	Max.	
Vertical display area	tvd	600			H
VSYNC period time	tv	624	635	750	H
VSYNC pulse width	tvpw	1	-	20	H
VSYNC Blanking (tvb)	tvb	23	23	23	H
VSYNC Front porch (tvfp)	tvfp	1	12	127	H



Note 1 : Definition of Viewing Angle θ_x and θ_y :

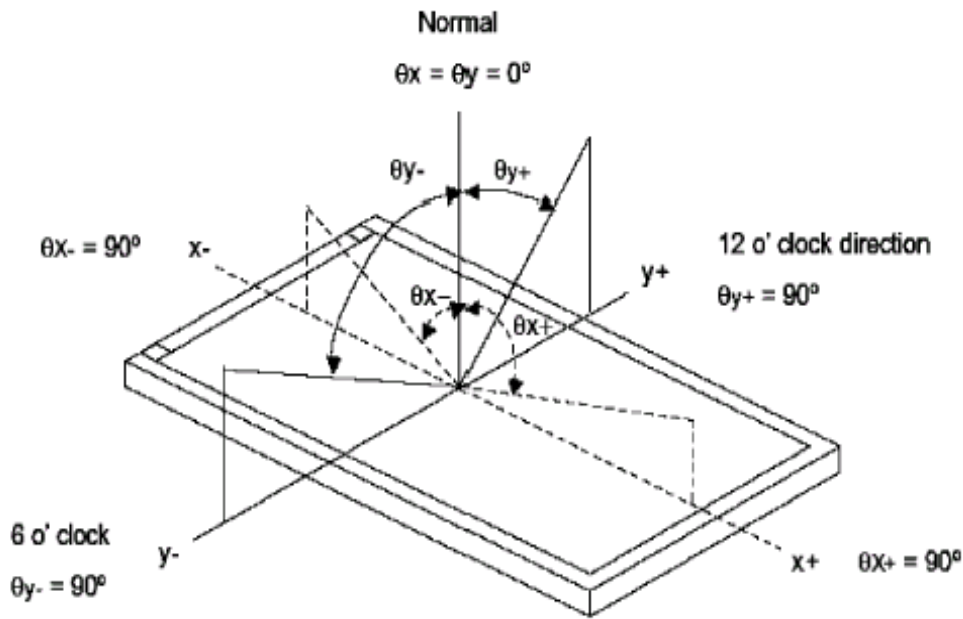

Note 2: Definition of contrast ratio CR:

$$CR = \frac{\text{Brightness of non-selected dots (white)}}{\text{Brightness of selected dots (black)}}$$

Note 3: Definition of response time (T_R , T_F)

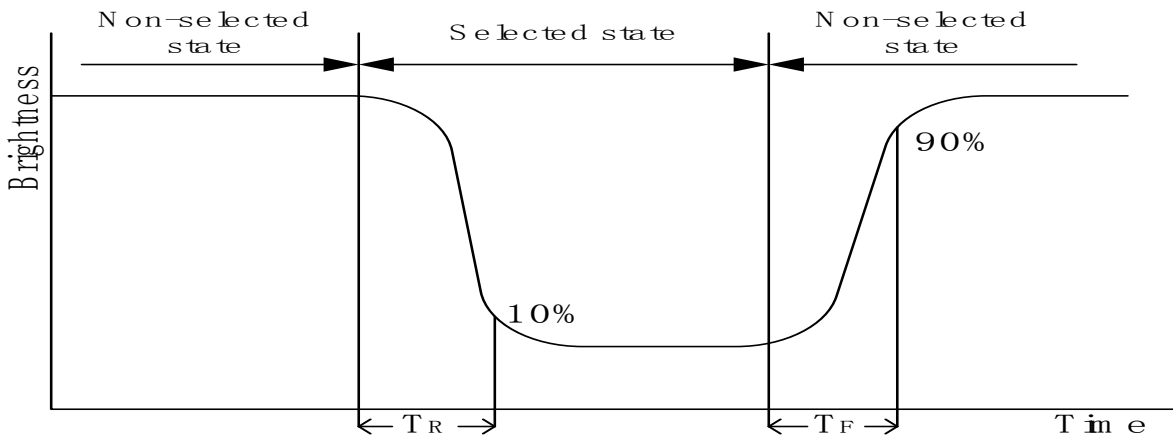



The brightness test equipment setup

20mA Field=2° (As measuring "black" image, field=2° is the best testing condition)

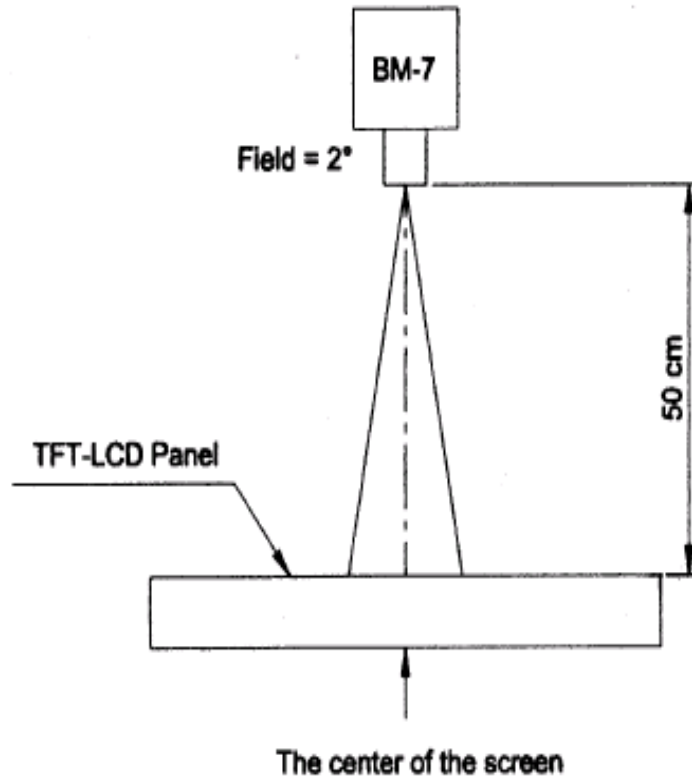

Note 4 :

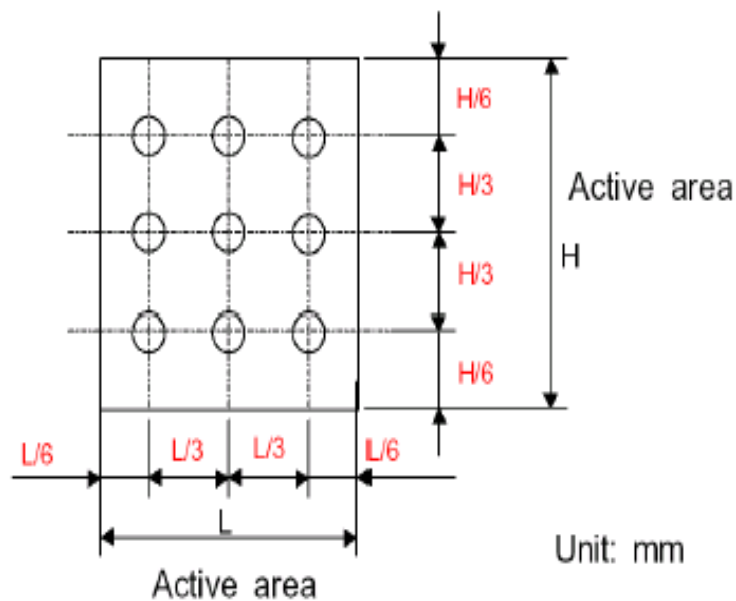



7. MCU Interface Pin Function

PIN NO.	SYMBOL	PIN NO.	SYMBOL
1	VCOM	31	LED-
2	VDD	32	LED-
3	VDD	33	SHLR
4	GND	34	UPDN
5	RESET	35	VGL
6	STBYB	36	NC/CABCEN1
7	GND	37	NC/CABCEN0
8	RXINO-	38	VGH
9	RXINO+	39	LED+
10	GND	40	LED+
11	RXIN1-		
12	RXIN1+		
13	GND		
14	RXIN2 -		
15	RXIN2+		
16	GND		
17	RXCLKIN-		
18	RXCLKIN+		
19	GND		
20	RXIN3-		
21	RXIN3+		
22	GND		
23	NC		
24	NC		
25	GND		
26	NC		
27	NC/PINCTL		
28	NC/DIMO		
29	AVDD		
30	GND		



LCM quality criteria-

8.1 RELIABILITY TEST

NO	ITEM	CONDITION	STANDARD
1	High temp. Storage	70°C, 48hrs	No function failure detected.
2	Low temp. Storage	-30°C, 48hrs	No function failure detected.
3	High temp. & High humidity operation	60°C, 90%, 48hrs	No function failure detected.
4	High temp. Operation	60°C, 48hrs	No function failure detected.
5	Low temp. Operation	-20°C, 48hrs	No function failure detected.
6	Thermal shock	-20°C, 30min~60°C, 30min, 10 cycles.	No function failure detected.

The reliability items will be fully performed in new sample qualification.

The reliability status will be tested as monitor during mass production. The individual reliability test shall be managed by lot. Moreover, the individual reliability item shall be decided according reliability plan.