



SPECIFICATION FOR TFT LCD MODULE

CUSTOMER : _____

CUSTOMER MODULE : _____

HL MODEL : HG070WV013T01

Preliminary Specification

Final Specification

Customer Confirmation column:

Approved by : _____ Dept. : _____ Data : _____

Please return one of the copies of the specification with your signature to us within two weeks after you receive this document. If it is not returned, we will assume that you agree to the entire contents of this specification document.

Designed by	Checked by	Approved by



CONTENTS

No.	ITEM	PAGE
1.	GENERAL INFORMATION	4
2.	DIAGRAM FOR LCM	5
3.	I/O CONNECTION & BLOCK DIAGRAM	6~7
4.	ABSOLUTE MAXIMUM RATINGS	8
5.	ELECTRICAL CHARACTERISTICS	9~10
6.	ELECTRO-OPTICAL CHARACTERISTICS	14~16
7.	RELIABILITY TEST CONDITIONS	17
8.	INSPECTION STANDARDS	18~19
9.	PACKAGE DRAWING	20



1. GENERAL INFORMATION

1.1 features

- 1) Structure: TFT PANNEL+IC+FPC+BL+CTP
- 2) IPS Type LCD 800 dot-segment and 480 dot-common outputs
- 3) 16.7M Color can be selected by software
- 4) White LED back light
- 5) RGB interface
- 6) Operation Temperature : -20~60℃
- 7) Storage Temperature : -30~70℃
- 8) CTP cover lens : Asahi Glass 0.7mm
- 9) CTP structure : Glass+Glass
- 10) LED life time: -/

1.2 General specification

Item of	Contents	Unit
Panel Size	7.0	inch
LCD Type	a-si/TRANSMISSIVE	/
Display mode	Normally White	/
Pixel arrangement	800*3 (RGB)*480	Dots
Pixel pitch (W*H)	64.2(H)*179 (V)	um
Active Area	154.08(H)*85.92(V)	Mm
Module area (W*H*T)	171.5 (H)*110.3(V)*5.05(T)	Mm
Recommended Viewing Direction	6	0' clock
Interface	RGB	/
Luminance for LCM	300	cd/m2
Weight	TBD	g



2. DIAGRAM FOR LCM

由 Autodesk 教育版产品制作

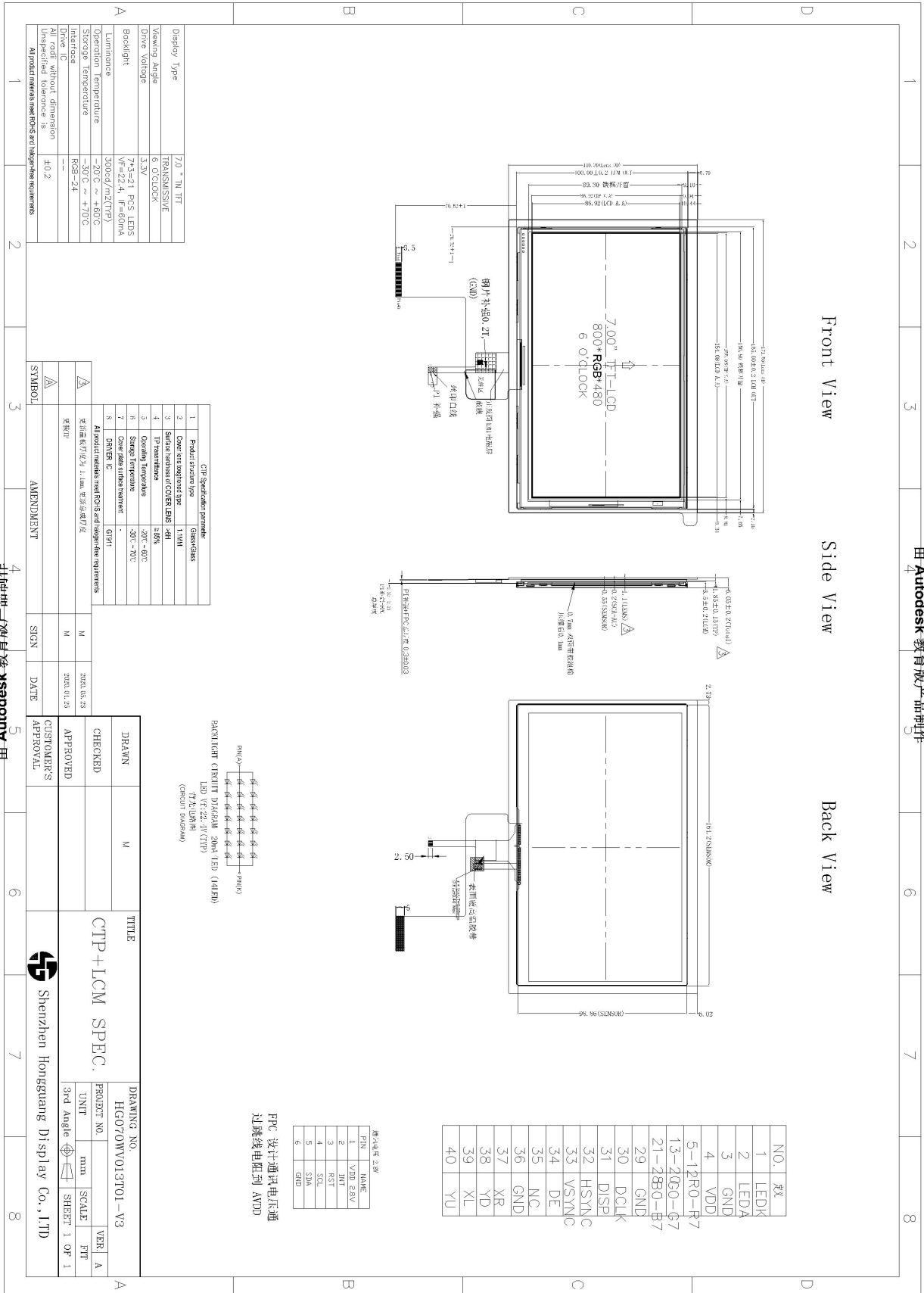

由 Autodesk 教育版产品制作



3. I/O CONNECTION & BLOCK DIAGRAM

3.1 I/O connection

LCM Pin NO.	Symbol	I/O	Description
1	LEDK	P	LED Cathode
2	LEDA	P	LED Anode
3	GND	P	Ground
4	VCC	P	power input
5-12	R0~R7	I	Red data
13-20	G0~G7	I	Green data
21-28	B0~B7	I	Blue data
29	GND	P	Ground
30	CLK	I	Parallel RGB clock input
31	DISP	I	
32	HSYNC	I	Horizontal Synchronization
33	VSNC	I	Vertical Synchronization
34	DE	I	DATA INPUT Enable
35	NC	-	
36	GND	P	Ground
37	XR		Touch panel Right
38	YD		Touch panel Down
39	XL		Touch panel Left
40	YU		Touch panel Up

I: Input; O: Output; P: Power

TP Pin NO.	Symbol	I/O	Description
1	AVDD	P	TP-VCC(2.8V) Power Supply for TP
2	INT	O	Interrupt signals for TP
3	RST	I	The signal will reset the TP, Signal is active low.
4	SCL	I	I2C clock signals for TP
5	SDA	I/O	I2C data signals for TP
6	GND	P	Power Ground



3.2 block diagram

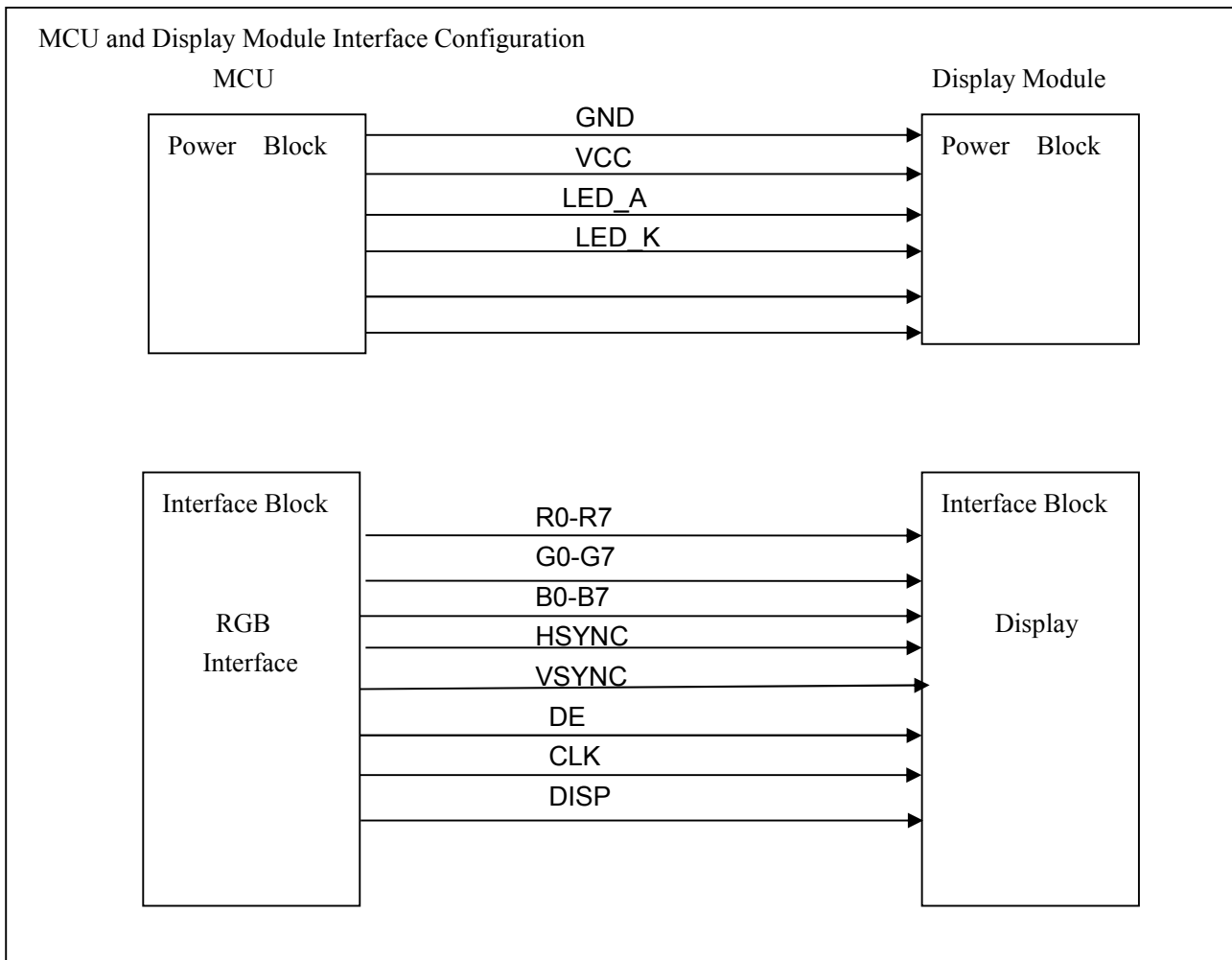



4. ABSOLUTE MAXIMUM RATINGS

(GND=AGND=0V)

Parameter of absolute maximum ratings 参数	Symbol 符号	Min 最小值	Max 最大值	Unit 单位
Power supply voltage	VCC	-0.3	3.3	V
Backlight forward current	I _{LED}	-0.001	30	mA(For each led)
Reverse Voltage	V _R	-	10	V
Operating temperature	T _{op}	-20	60	°C
Storage temperature	T _{st}	-30	70	°C
Humidity	RH	-	90%(Max)/60°C	RH

5. ELECTRICAL CHARACTERISTICS

5.1 Typical Operation Conditions

Item	Symbol	Min	Typ	Max	Unit	Applicable terminal
Supply voltage for logic	V_{DD}	2.8	3.0	3.3	V	V_{DD}
Input voltage	V_{IL}	-0.3	-	$0.2 V_{DD}$	V	
	V_{IH}	$0.8 V_{DD}$	-	V_{DD}	V	
Input leakage current	I_{LKG}				μA	
AVDD current		9.4	9.6	9.8	V	
VGH current		17	18	19	V	
VGL current		-9	-8	-7	V	
VCOM current		2.8	3.0	3.2	V	
LED Forward voltage	V_f	20.3	22.4	24.5	V	-
Input backlight current	I_{LED}		60mA		mA	With One LED

Note: The "LED life time" is defined as the module brightness decrease to 50% of original brightness at $I_L=20mA$ (for each led). The LED life time could be decreased if operating I_L is larger than 20mA

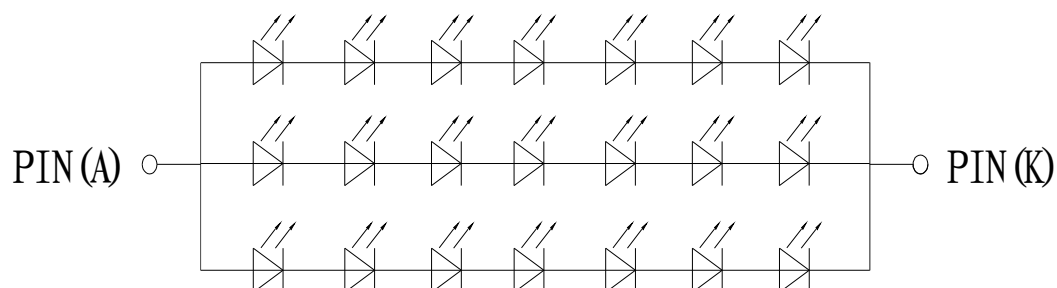



5.2 DC CHARACTERISTICS

Parameter	Symbol	Spec.			Unit	Condition
		Min.	Typ.	Max.		
Power supply voltage	VDD	2.7	3.3	3.8	V	-
Power supply voltage	VDDA	6.5	-	13.5	V	-
Low level input voltage	V _{IL}	0	-	0.3VDD	V	For digital circuit
High level input voltage	V _{IH}	0.7VDD	-	VDD	V	For digital circuit
Output low voltage	V _{OL}	-	-	VSS+0.4	V	I _{OL} =400μA
Output high voltage	V _{OH}	VDD-0.4	-	-	V	I _{OCH} =-400μA
Pull low/high resistance	R _i	200	250	300	kΩ	For the digital input pin @VDD=3.3V
Input leakage current	I _i	-	-	±1	uA	For digital circuit
Digital Operation current	I _{DD}	-	6	14	mA	Dual gate mode or Cascade mode slave, Fclk=60MHz, LD=48KHz, VDD=3.3V, CABC disable, No load
		-	7	16	mA	Cascade mode master, Fclk=60MHz, LD=48KHz, VDD=3.3V, CABC disable, No load
Digital stand-by current	I _{st1}	-	10	50	μA	Clock & all functions are stopped
Analog Operating current	I _{DDA}	-	6	8	mA	No load, Fclk=50MHz, FLD=48KHz @ VDDA=10V, V1=8V, V14=0.4V
Analog Stand-by current	I _{st2}	-	10	50	μA	No load, clock & all functions are stopped
Input level of V1~V7	V _{ref1}	0.4VDDA	-	VDDA-1	V	Gamma correction voltage input
Input level of V8~V14	V _{ref2}	0.1	-	0.6VDDA	V	Gamma correction voltage input
Output Voltage deviation	V _{od1}	-	±20	±35	mV	V _O =VSSA+0.1V~VSSA+0.5V & V _O =VDDA-0.5V~VDDA-0.1V
Output Voltage deviation	V _{od2}	-	±15	±20	mV	V _O =VSSA+0.5V~VDDA-0.5V
Output Voltage Offset between Chips	V _{oc}	-	-	±20	mV	V _O =VSSA+0.5V~VDDA-0.5V
Dynamic Range of Output	V _{dr}	0.1	-	VDDA-0.1	V	SO1~SO1200
Sinking Current of Outputs	I _{OLy}	80	-	-	μA	SO1~SO1200; V _O =0.1V vs. 1.0V, VDDA=13.5V
Driving Current of Outputs	I _{OHy}	80	-	-	μA	SO1~SO1200 ;V _O =0.1V vs. 12.5V, VDDA=13.5V
Resistance of Gamma Table	R _g	0.7*R _n	1.0*R _n	1.3*R _n	Ω	R _n : Internal gamma resistor

5.3 RGB MODE AC ELECTRICAL CHARACTERISTICS

(Detail please refer IC data sheet)

Parameter	Symbol	MIN.	Typ.	MAX.	UNIT	Conditions
VDD Power On Slew rate	T	-	-	20	ms	From 0V to 90% VDD
RSTB pulse width	T	10	-	-	us	CLKIN = 45MHz
CLKIN cycle time	T _{cph}	20	-	-	ns	
CLKIN pulse duty	T _{cwh}	40	50	60	%	
VSD setup time	T _{vst}	8	-	-	ns	
VSD hold time	T _{vhd}	8	-	-	ns	
HSD setup time	T _{hst}	8	-	-	ns	
HSD hold time	T _{hhd}	8	-	-	ns	
Data set-up time	T _{dsu}	8	-	-	ns	D0[7:0], D1[7:0], D2[7:0] to CLKIN
Data hold time	T _{dhd}	8	-	-	ns	D0[7:0], D1[7:0], D2[7:0] to CLKIN
DE set-up time	T _{esu}	8	-	-	ns	
DE hold time	T _{ehd}	8	-	-	ns	
Output stable time	T _{sst}	-	-	6	us	10% to 90% target voltage. CL=120pF, R=10K ohm



Parameter	Symbol	MIN.	Typ.	MAX.	UNIT	Conditions
CLKIN Frequency	Fclk	-	33	50	MHz	VDDD = 2.3V ~ 3.6V
CLKIN Cycle Time	Tclk	20	30	-	ns	
CLKIN Pulse Duty	Tcwh	40	50	60	%	Tclk
Time from HSD to Source Output	Thso	-	Tld	-	CLKIN	
Time from HSD to LD	Thld	-	Tld	-	CLKIN	
Time from HSD to STV	Thstv	-	2	-	CLKIN	
Time from HSD to CKV	Thckv	-	20	-	CLKIN	
Time from HSD to OEV	Thoev	-	4	-	CLKIN	
LD Pulse	Twid	-	10	-	CLKIN	
CKV Pulse Width	Twckv	-	66	-	CLKIN	
OEV Pulse Width	Twoev	-	Tld+10	-	CLKIN	

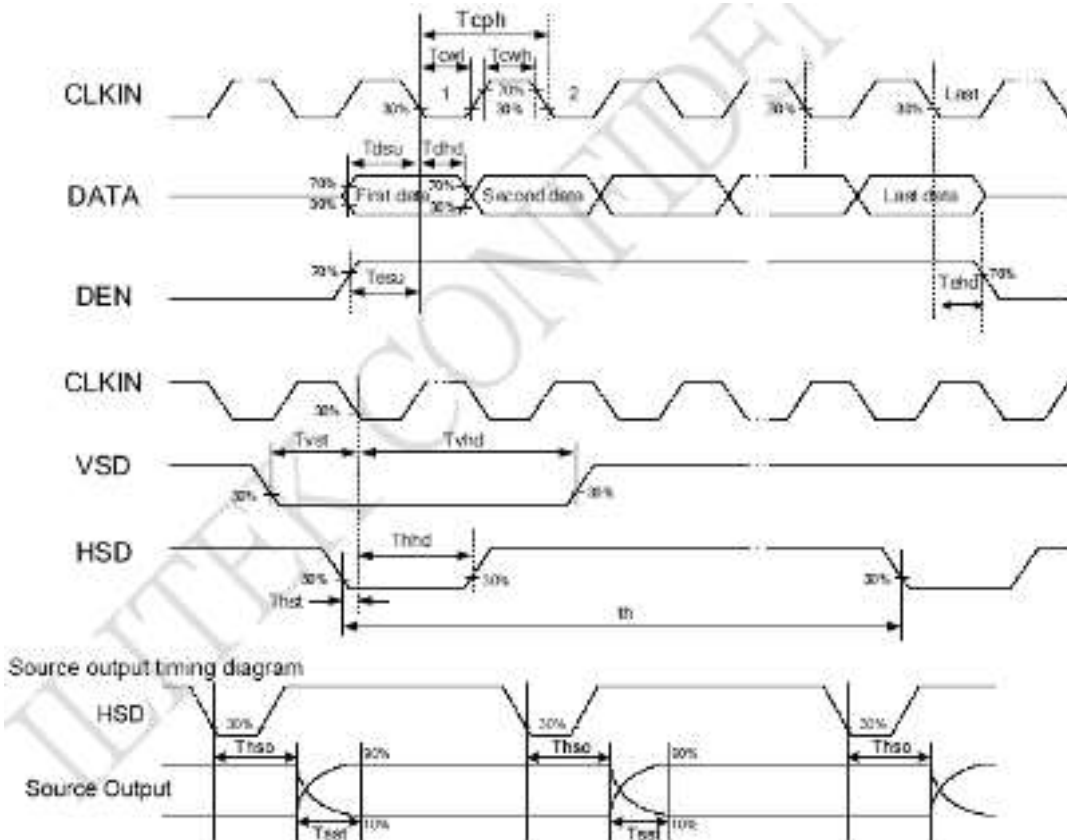

5.4. Data input format for RGB

5.4.1 For 24-Bit RGB input

Parameter	Symbol	Min.	Typ.	Max.	Unit	Conditions
CLKIN Frequency	Fclk	-	33	50	MHz	VDD = 2.7V ~3.6V
CLKIN Cycle Time	Tclk	20	30	-	ns	
CLKIN Pulse Duty	Tcwh	40	50	60	%	Tclk
Time from HSD to Source Output	Thso	-	64	-	CLKIN	
Time from HSD to LD	Thld	-	64	-	CLKIN	
Time from HSD to STV	Thstv	-	2	-	CLKIN	
Time from HSD to CKV	Thckv	-	20	-	CLKIN	
Time from HSD to OEV	Thoev	-	4	-	CLKIN	
LD Pulse Width	Twid	-	10	-	CLKIN	
CKV Pulse Width	Twckv	-	66	-	CLKIN	
OEV Pulse Width	Twoev	-	92	-	CLKIN	



Vertical input Timing

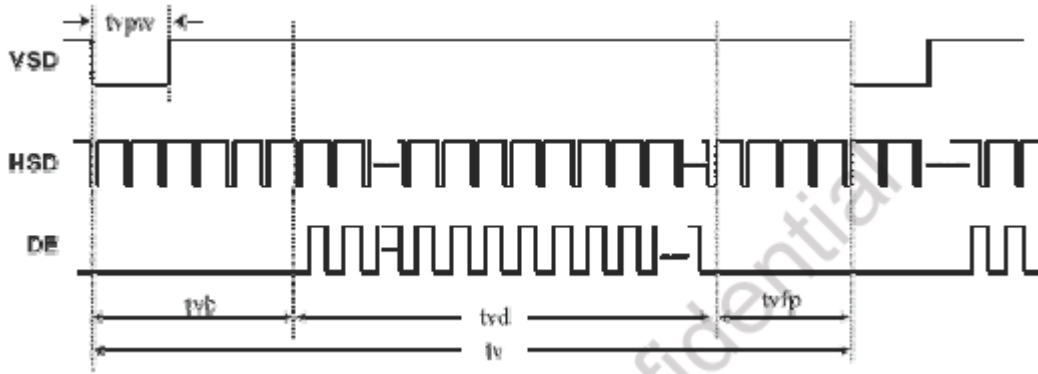

Horizontal input Timing

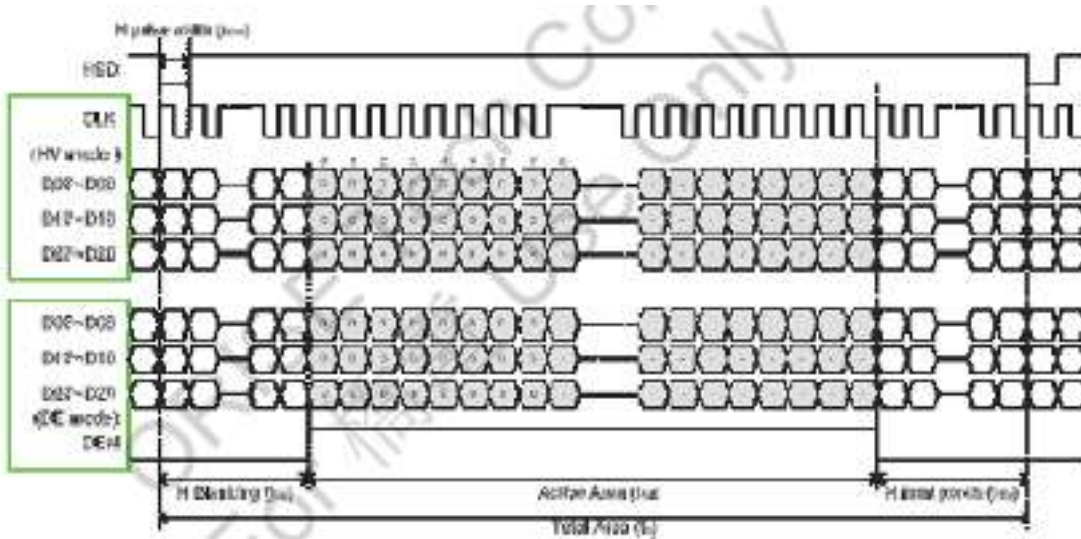



Timing Characteristic

For 800x480 panel

Horizontal input timing

Parameter	Symbol	Value			Unit
		Min.	Typ.	Max.	
Horizontal display area	thd	800			DCLK
DCLK frequency	fclk	-	30	50	MHz
1 Horizontal Line	th	928			DCLK
HSD pulse width	thpw	Min.	1		
		Typ.	48		
		Max.	-		
HSD Back Porch (Blanking)	thb	-	88	-	
HSD Front Porch	thfp	-	40	-	

Vertical input timing

Parameter	Symbol	Value			Unit
		Min.	Typ.	Max.	
Vertical display area	tvd	480			H
VSD period time	tv	-	525	-	H
VSD pulse width	tvpw	-	3	-	H
VSD Back Porch (Blanking)	tvb	-	32	-	H
VSD Front Porch	tvfp	-	13	-	H



6. ELECTRO-OPTICAL CHARACTERISTICS

Parameter		Symbol	Condition	Min.	Typ.	Max.	Unit	Note	
Contrast Ratio (Center point)		C/R	-	400	500	-	-	Note(1)	
Luminance uniformity		U _w	$\theta = 0$. Normal viewing angle B/L On Note(1)	80	85	-	%	Note(2)	
Response Time		Tr + Tf		-	25	40	ms	Note(3)	
Color Chromaticity (CIE 1931)	White	W _x			0.30			参考 值	Note(5)
		W _y			0.32				
	Red	R _x			0.571				
		R _y			0.352				
	Green	G _x		-0.02	0.345	+0.02			
		G _y			0.557				
	Blue	B _x			0.148				
		B _y			0.128				
Viewing Angle	Hor.	∅ 3R	C/R≥10	40	45	-	Deg	Note(4)	
		∅ 9L		40	45	-			
	Ver.	∅ 12U		30	35	-			
		∅ 6D		10	15	-			



Note1 Definition of Contrast Ratio (CR):

$$\text{Contrast ratio (CR)} = \frac{\text{Luminance measured when LCD on the "White" state}}{\text{Luminance measured when LCD on the "Black" state}}$$

Note2: Definition of Luminance Uniformity: Active area is divided into 9 measuring areas (Shown in below), every measuring point is placed at the center of each measuring area.

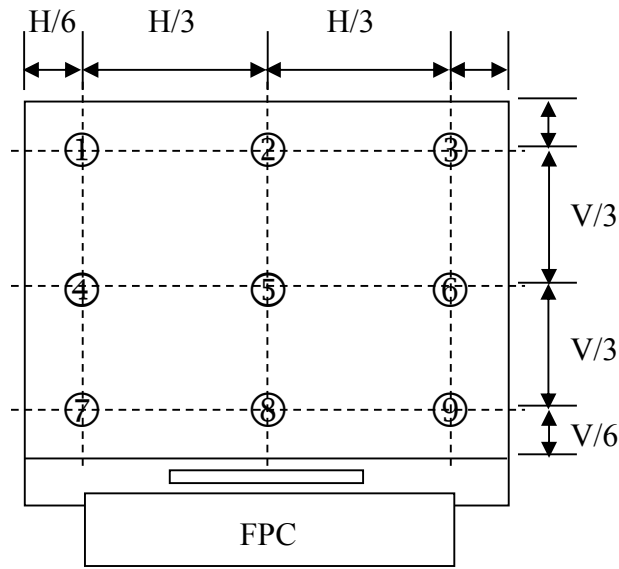

The spot locations for luminance measurement

$$\text{Luminance Uniformity} = \frac{H/6 \cdot B_{\min}}{V/6 \cdot B_{\max}} \times 100\%$$

B_{\max} : The measured maximum luminance of all measurement position.

B_{\min} : The measured minimum luminance of all measurement position.

Note 3: Definition of Response time: Sum of T_r and T_f

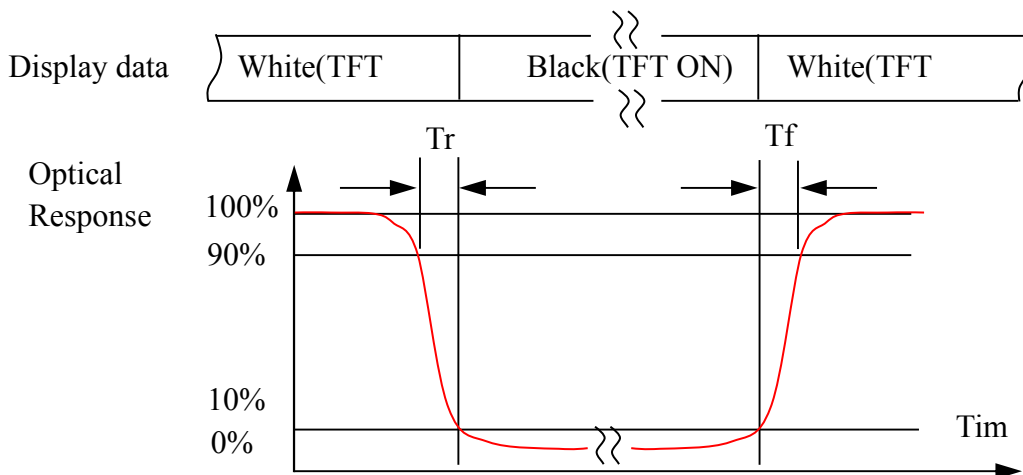



Note4.Definition of Viewing Angle: The viewing angle range that the CR \geq 10

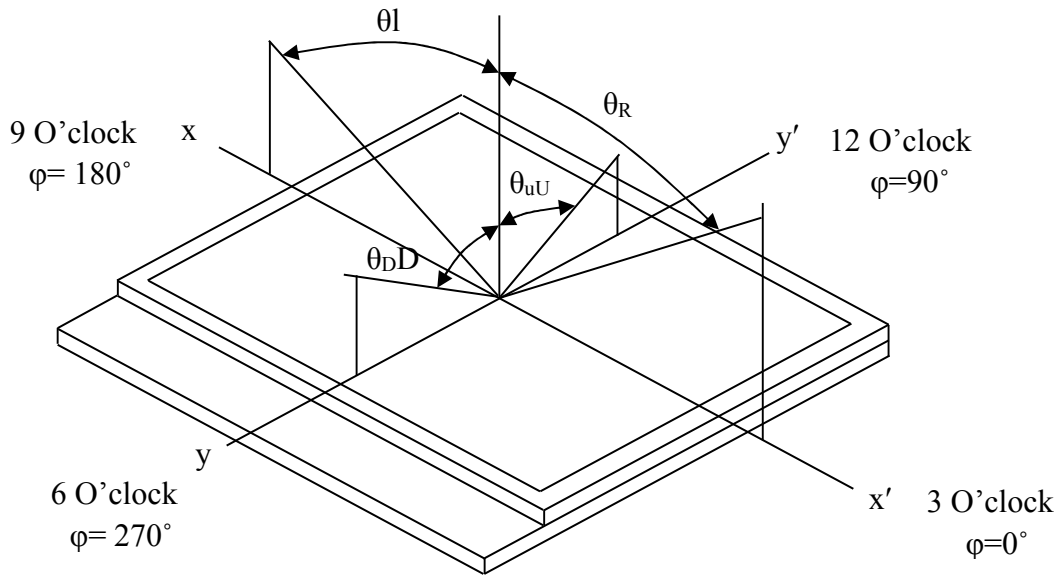

Note 5: Definition of Color Chromaticity (CIE 1931)

Color coordinate of white & red, green, blue at center point.



7. RELIABILITY TEST CONDITIONS

No	Test Item	Test Condition	STANDARD
1	High Temperature Storage	+70°C / 96Hours	1. Functional test is OK. Missing Segment, short, unclear segment, on-display, display abnormally and liquid crystal leak are un-allowed. 2. No low temperature bubbles, end seal loose and fall, frame rainbow.
2	Low Temperature Storage	-30°C / 96Hours	
3	High Temperature Operating	+60°C / 96Hours	
4	Low Temperature Operating	-20°C / 96Hours	
5	Thermal and cold shock	0°C↔+50°C x 10cycles (30min) (5min) (30min)	
6	Operate at High Temperature and Humidity	60°C x 90%RH / 24H	
7	Vibration Test	Frequency: 10Hz~55Hz~10Hz Amplitude:1.5mm, 2 hours for each direction of X, Y, Z	1. Function test is OK. 2. No glass crack, chipped glass, end seal loose and fall, epoxy frame crack and so on. 3. No structure loose and fall.
8	Dropping test	Drop to the ground from 1m height, 1 corner, 3 edges, 6 surfaces.	
9	ESD test	Contact: ±6KV Air: ±10KV 150PF/330Ω,5Points/panel,5times	The test results shall be subject to the whole machine test.

NOTE:

1. The reliability items will be fully performed in new sample qualification,
2. The reliability status will be tested as monitor during mass production. Individual reliability test shall be performed by lot, Moreover, the individual reliability item shall be decided according to reliability plan.
3. All samples are inspected after keeping in the room with normal temperature and humidity for 2 hours or above.
4. Vibration test: It is not necessary to test for those products without assembly frame, backlight, PCB and so on.
5. Dropping test: It is necessary for affirming new package.
6. For the high temperature and high humidity test, pure water of over 10 MΩ.cm should be used.
7. Each test item applies for test LCM only once. Then tested LCM cannot be used again in any other test item.
8. The quantity of LCM examination for each test item is 5pcs to 10pcs.



8. INSPECTION STANDARDS

8.1 AQL Sampling inspection standard

使用 GB/T 2828-2003 一般 II 水平, 采用正常检查一次抽样方式; 具体抽检方式参照《成品检验管理程序》、《抽样管理规范》

缺陷区分	AQL 允收水准
严重缺陷	0 收 1 退
重缺	0.4
轻缺	1.0

8.2 Inspect the condition

8.2.1 在 20—40W 日光灯的照明条件下, 样品离检查者眼睛约 30cm 处进行检查。检验方向以垂直线前后左右 45° (以时钟 3 点、6 点、9 点、12 点)

8.2.2 检验者视力需达到标准视力 1.0 以上。

8.2.3 检验者需戴静电手环、两手八个手指套。

8.2.4 外观检验者以目视检查或以菲林对比卡比对。

8.2.5 电性测试使用电测测架, 主板, 电源线及单片机。

8.2.6 若标准与规格书不符时, 以产品发行之规格书特殊检验规格、工程变更为准

8.2.7 辉色度检测请参照样品, 检测方法依照辉色度检验标准。

8.2.8 电测检验环境: 照度为 200LUX 以下, 外观检验环境: 照度为 600LUX-1000LUX, 检验时间: 1 秒-3 秒。

8.2.9 检验工具: 电测测架, 主板, 电源线及单片机, 菲林对比卡, 游标卡尺, 放大镜, 实体显微镜 (必要时) 等等。

8.3 Judgment criterion

小尺寸点、线判定标准: (6.2 寸以内)

1	点状缺陷 (磨伤、异物、针孔、凹痕、缺膜、气泡、白点、彩点、脏点)		判定 (A /B/C 区)	$D \leq 0.10$, 忽略不计, 但密集型不允许	MI	OK
				$0.1 < D \leq 0.15$, $ds \geq 10$		$N \leq 2$
				$0.15 < D \leq 0.2$, $ds \geq 10$		$N \leq 1$
				LCD 亮点: $0.15 < D$		$N \leq 1$
				$D > 0.2$		NG
			判定 (D 区)	同背面丝印油墨区杂质判定标准		
			注: 1) D 区的点状缺陷需在不影响 CTP 功能、客户组装及整机的外观的情况下, 判定 OK		MI	
2	线状缺陷 (磨伤、无感划伤、毛屑、纤维等)		判定 (A /B/C 区)	$W \leq 0.03mm$, $L \leq 3mm$, $ds \geq 10$	MI	$N \leq 2$
				$0.03mm < W \leq 0.05mm$, $L \leq 3mm$, $ds \geq 10$		$N \leq 1$
				$W > 0.05mm$ 或 $L > 3mm$		NG



中尺寸点、线判定标准：（6.2~8寸以内）

1	点状缺陷 (磨伤、异物、针孔、凹痕、缺膜、气泡、白点、彩点、脏点)		判定(A/B/C区)	$D \leq 0.10$, 忽略不计, 但密集型不允许 $0.15 < D \leq 0.25$, $ds \geq 10$ $0.25 < D \leq 3$, $ds \geq 10$ LCD亮点: $0.2 < D$ $D > 0.3$	MI	OK
			判定(D区)	同背面丝印油墨区杂质判定标准		N \leq 2 N \leq 1 N \leq 1 NG
			注: 1) D区的点状缺陷需在不影响CTP功能、客户组装及整机的外观的情况下, 判定OK		MI	
2	线状缺陷 (磨伤、无感划伤、毛屑、纤维等)		判定(A/B/C区)	$W \leq 0.03mm$, $L \leq 3mm$, $ds \geq 10$ $0.03mm < W \leq 0.05mm$, $L \leq 3mm$, $ds \geq 10$	MI	N \leq 2
				$W > 0.05mm$ 或 $L > 3mm$		N \leq 1
						NG

大尺寸点、线判定标准：（8.1~13.3寸以内）

1	点状缺陷 (磨伤、异物、针孔、凹痕、缺膜、气泡、白点、彩点、脏点)		判定(A/B/C区)	$D \leq 0.1$, 忽略不计, 但密集型不允许 $0.15 < D \leq 0.3$, $ds \geq 10$ $0.3 < D \leq 0.35$, $ds \geq 10$ LCD亮点: $0.25 < D$ $D > 0.35$	MI	OK
			判定(D区)	同背面丝印油墨区杂质判定标准		N \leq 2 N \leq 1 N \leq 1 NG
			注: 1) D区的点状缺陷需在不影响CTP功能、客户组装及整机的外观的情况下, 判定OK		MI	
2	线状缺陷 (磨伤、无感划伤、毛屑、纤维等)		判定(A/B/C区)	$W \leq 0.05mm$, $L \leq 5mm$, $ds \geq 10$ $0.05mm < W \leq 0.07mm$, $L \leq 5mm$, $ds \geq 10$	MI	N \leq 2
				$W > 0.07mm$ 或 $L > 5mm$		N \leq 1
						NG



9. PACKAGE DRAWING

