



SPECIFICATION FOR TFT LCD MODULE

CUSTOMER : _____

CUSTOMER MODULE : _____

HL MODEL : HG070WV026

Preliminary Specification

Final Specification

Customer Confirmation column:

Approved by : _____ Dept. : _____ Data : _____

Please return one of the copies of the specification with your signature to us within two weeks after you receive this document. If it is not returned, we will assume that you agree to the entire contents of this specification document.

Designed by	Checked by	Approved by



REVISION STATUS

Revision	Description	Page	Revision Date
1.0	First Revision	---	2019-12-12



Contents	Page
1.0. General Specification	4
2.0. Absolute Maximum Ratings	5
3.0. Optical characteristics	6
4.0. Block diagram	10
5.0. Interface pin connection	12
6.0. Electrical characteristics	14
7.0. Reliability test items	19
8.0. Outline dimension	20
9.0. BOM list	21
10.0. Lot mark	22
11.0. Package specification	23
12.0. General Precaution	24



1.0 GENERAL DESCRIPTION

1.1 Introduction

The model HG070WX026 is a color active matrix thin film transistor (TFT)liquid crystal display (LCD) that uses amorphous silicon TFT as a switching device.This model is composed of a TFT LCD panel, a driving circuit and a back- lightsystem. This TFT LCD has a 7.0 (16:9) inch diagonally measured active displayarea with WVGA (800 horizontal by 480 vertical pixel) resolution.

1.2 Features

- 7 (16:9 diagonal) inch configuration
- 6 bits + FRC driver with 1channel TTL interface
- LED Back-light
- Up/Down, Left/Right reversion selection
- RoHS/ Halogen Free Compliance

1.3 Applications

- Automotive
- Mobile NB
- Digital Photo frame
- Multimedia applications and Others AV system

1.4 General information

Item	Specification	Unit
Screen Size	7.0 inches	Diagonal
Number of Pixel	800 RGB (H) ×480(V)	Pixels
Display area	154.08(W) × 85.92(H) mm	mm
Outline Dimension	164.90 x 100.00 x 5.70(Typ)	mm
Display mode	Normally white, TN	--
Pixel arrangement	RGB Vertical stripe	--
Pixel pitch	0.0642(W) × 0.1790(H) mm	mm
Back-light	LED Side-light type	--
Surface treatment	Anti-glare, Hard-Coating (3H) EWV film	--
Interface	TTL	



1.5 Mechanical Information

Item		Min.	Typ.	Max.	Unit
Module Size	Horizontal (H)	164.70	164.90	165.10	mm
	Vertical (V)	99.80	100.0	100.20	mm
	Depth (D)	5.50	5.70	5.90	mm
Weight		--	TBD	--	g

2.0 ABSOLUTE MAXIMUM RATINGS

2.1 Electrical Absolute Rating

2.1.1 TFT LCD Module

Item	Symbol	Min	Max	Unit	Note
Digital Supply Voltage	VCC	-0.3	6.0	V	GND=0
Gate Off Voltage	AVDD	0.5	15.0	V	AGND=0

Note:

1. Stresses above those listed under "Absolute Maximum Rating" may cause permanent damage to the device. These are stress ratings only. Functional operation of this device at indicated in the operational sections(6.1) of this specification.

2. $T_a=25\pm 2^{\circ}\text{C}$

2.2 Environment Absolute Rating

Item	Symbol	Min.	Max.	Unit	Note
Storage temperature	T_{STG}	-30	70	$^{\circ}\text{C}$	
Operating temperature	T_{OPR}	-20	60	$^{\circ}\text{C}$	

Note: If users use the product out off the environmental operation range(temperature and humidity), it will have visual quality concerns.



3.0 OPTICAL CHARACTERISTICS

3.1 Optical specification

Item	Symbol	Condition	Min	Type	Max	Unit	Note	
White luminance (Center)	YL	$\theta=0$ Normal Viewing Angle	1000	1050	TBD	nits	(1)(4)(6)	
Response time	Rising		T R	--	10	20	msec	(1)(3)
	Falling		T F		15	30	msec	
Panel Transmittance				--	5.11	--	%	
Contrast ratio	CR			400	500	--	--	(1)(2)
Color Chromaticity (CIE 1931)	white		Wx	0.260	0.310	0.360		(1)(4)
		Wy	0.280	0.330	0.380			
Viewing Angle	Hor.	θ_L	60	70	--		(1)(4)	
		θ_R	60	70	--			
	Ver.	θ_U	40	50	--			
		θ_D	60	70	--			
Brightness	BUNI	$\theta=0$	70	80	--	%	(5)	
NTSC(CIE 1931)		S	--	45	--	%	C-light	
Optima View Direction			6: 00 o'clock					

1), 客户签样亮度 $\pm 10\%$ = 大货亮度, 小于10%视为不良。

2), 大货同一批色调一致的情况下(目视同为冷色或暖色)与客户签样相比, X色坐标相差 ± 0.015 , Y色坐标相差 ± 0.02 以内视为正常OK品。

3.2 Measuring Condition

- Measuring surrounding: dark room
- LED current IL: 300mA
- Ambient temperature: $25\pm 2^\circ\text{C}$
- 30min. warm-up time

3.3 Measuring Equipment

- BM-7 optical characteristics.
- Measuring spot size: 20 ~ 21mm

Note (1) Definition of Viewing Angle

Viewing angle is the angle at which the contrast ratio is greater than 10. The



viewing angles are determined for the horizontal or 3, 9 o'clock direction and the vertical or 6, 12 o'clock direction with respect to the optical axis which is normal to the LCD surface (see FIGURE 1).

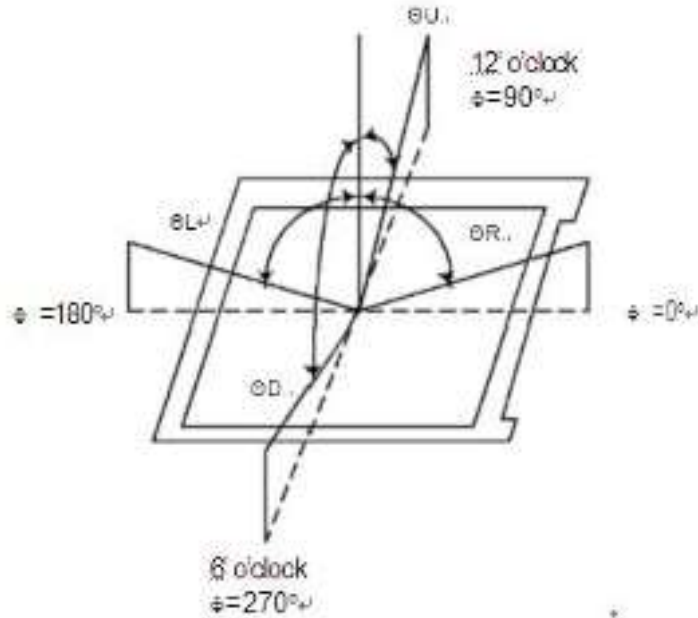

Note (2) Definition of Contrast Ratio(CR): Measured at the center point of panel

$$CR = \frac{\text{Luminance with all pixels white}}{\text{Luminance with all pixels black}}$$

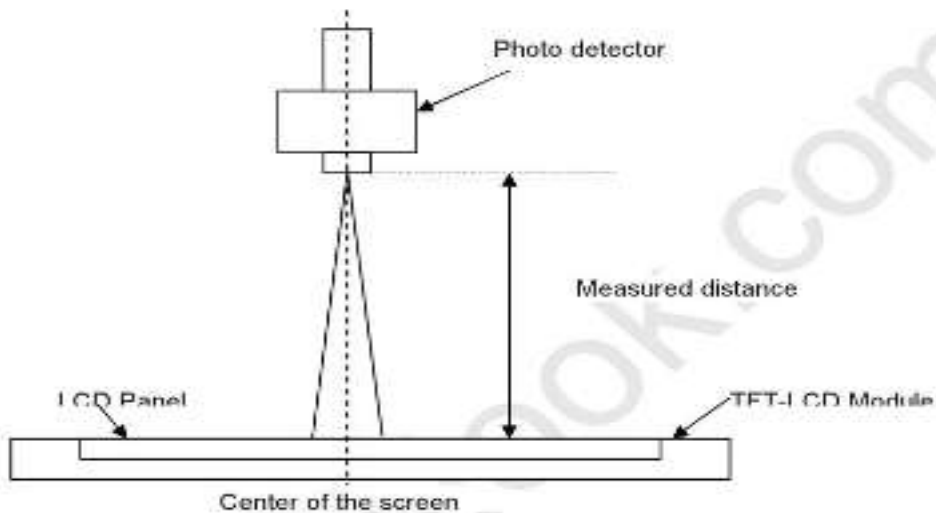

Note (3) Definition of Response Time: Sum of TR and TF

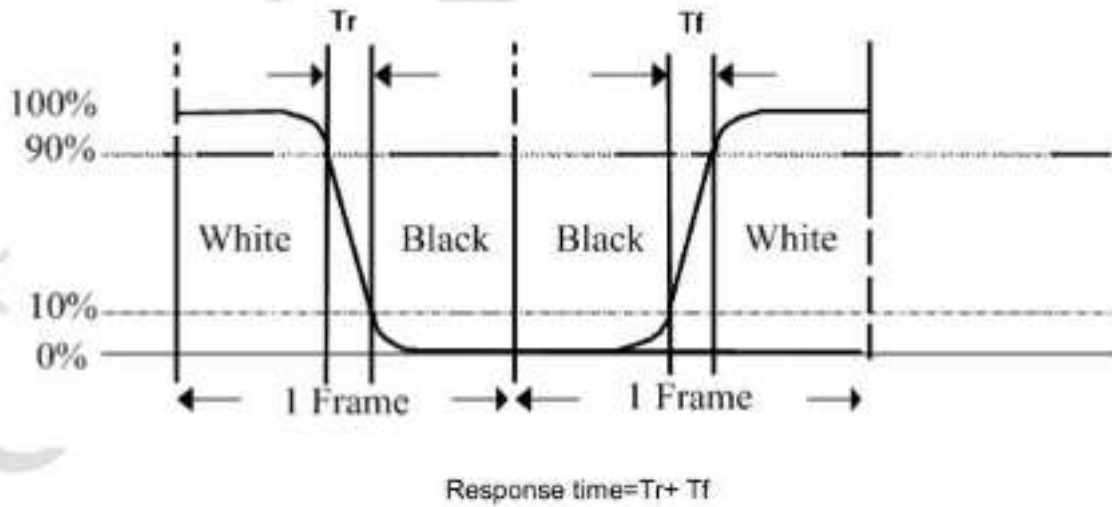

Note (4) Definition of optical measurement setup

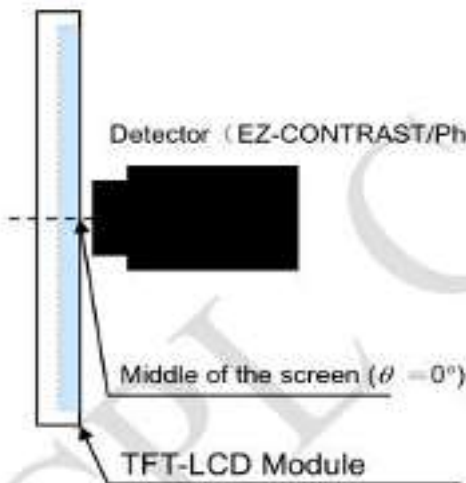

Measurement of viewing angle range, Response time.

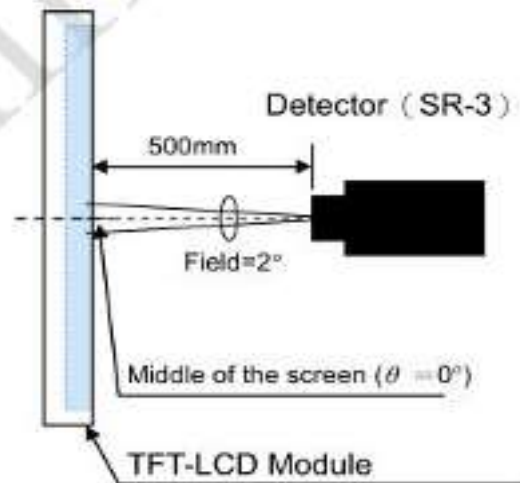

Measurement of Contrast, Luminance, Chromaticity.



(Min Luminance of 9 points)

$$\text{Luminance uniformity} = \frac{\text{Min Luminance of 9 points}}{\text{Max Luminance of 9 points}} \times 100 \%$$

(Max Luminance of 9 points)

Note (6) Rubbing Direction (The different Rubbing Direction will cause the different optima view direction.)

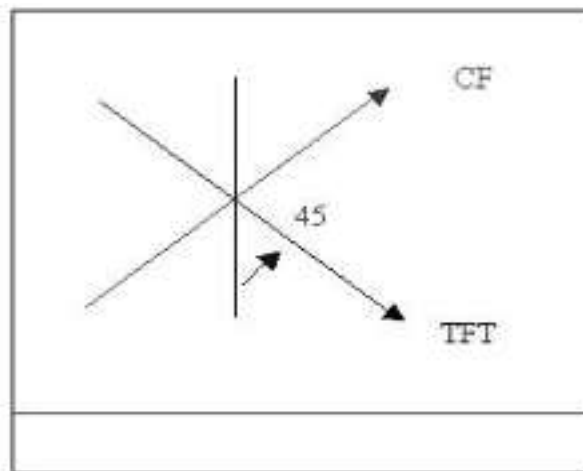

(Alignment Direction)

4.0 BLOCK DIAGRAM

4.1 TFT LCD Module

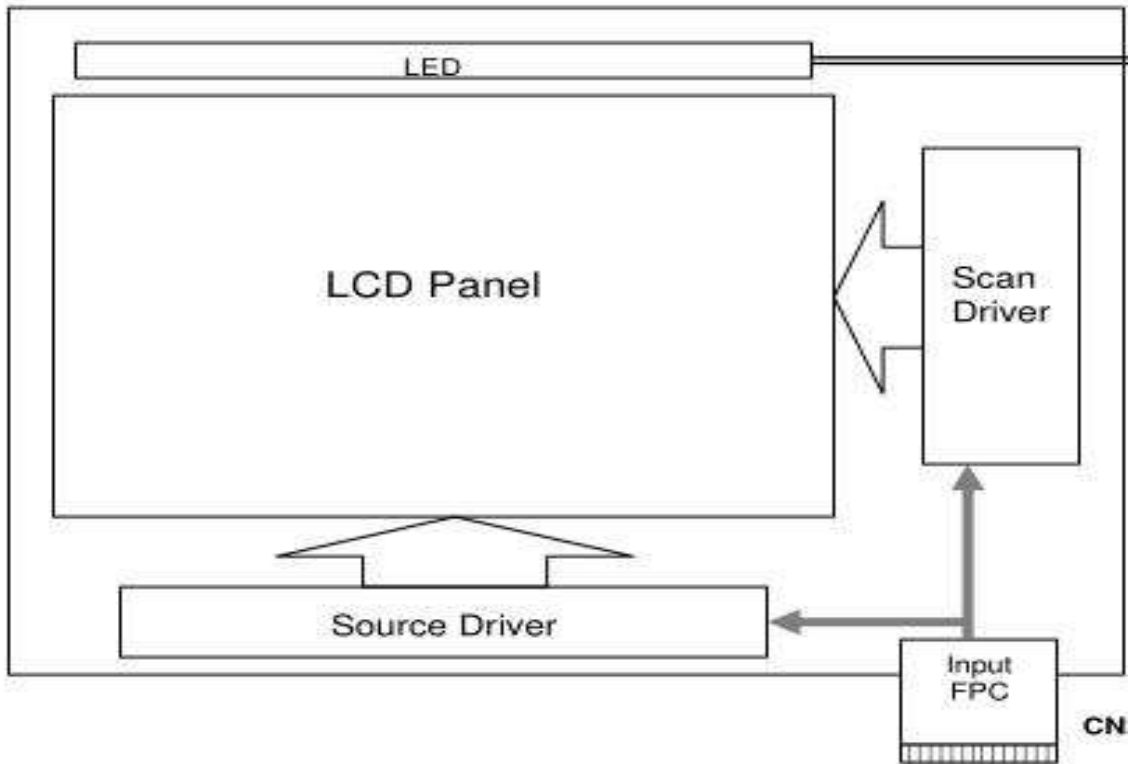

4.2 Pixel Format

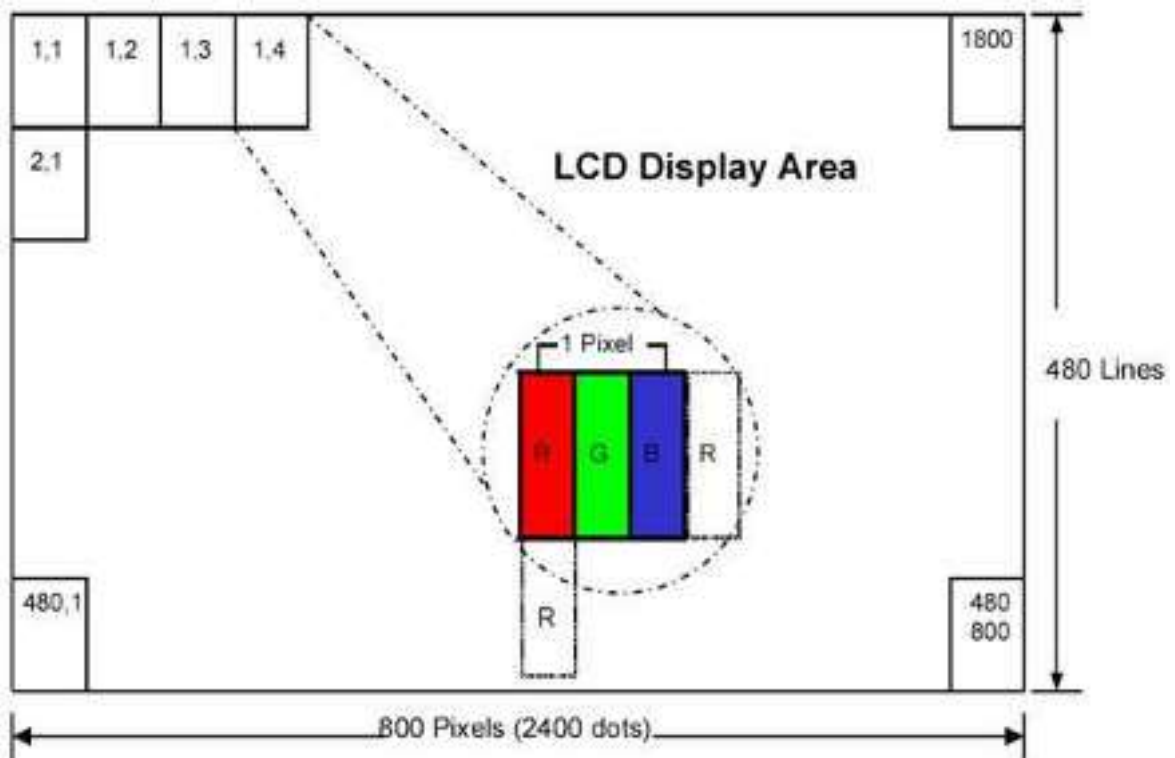

5.0 INTERFACE PIN CONNECTION



5.1 TFT LCD Module: FPC UP Connector, (FH28-50S-0.5SH (HIROSE), 50pin,pitch = 0.5mm)

Pin No.	Symbol	Function	Remark
1	LED+	Power for LED backlight(Anode)	
2	LED+	Power for LED backlight(Anode)	
3	LED-	Power for LED backlight(Cathode)	
4	LED-	Power for LED backlight(Cathode)	
5	GND	Power Ground	
6	VCOM	Common Voltage	
7	VDD	Digital Power	
8	MODE	DE/SYNC Mode Select. Normally Pull High H :DE mode. L :HSD/VSD mode	
9	DEN	Date Enable signal	
10	VSYNC	Vertical sync input. Negative polarity	
11	HSYNC	Horizontal sync input. Negative polarity	
12	B7	Blue Data Input(MSB)	
13	B6	Blue Data Input	
14	B5	Blue Data Input	
15	B4	Blue Data Input	
16	B3	Blue Data Input	
17	B2	Blue Data Input	
18	B1	Blue Data Input	
19	B0	Blue Data Input(LSB)	
20	G7	Green Data Input(MSB)	
21	G6	Green Data Input	
22	G5	Green Data Input	
23	G4	Green Data Input	
24	G3	Green Data Input	
25	G2	Green Data Input	
26	G1	Green Data Input	
27	G0	Green Data Input(LSB)	
28	R7	Red Data Input(MSB)	
29	R6	Red Data Input	
30	R5	Red Data Input	
31	R4	Red Data Input	
32	R3	Red Data Input	
33	R2	Red Data Input	
34	R1	Red Data Input	
35	R0	Red Data Input(LSB)	

Pin No.	Symbol	Function	Remark
36	GND	Power Ground	



37	DCLK	Clock Input	
38	GND	Power Ground	
39	SHLR	Left or Right Display Control	
40	UPDN	Up/Down Display Control	
41	VGH	Positive Power for TFT	
42	VGL	Negative Power for TFT	
43	AVDD	Analog Power	
44	RSTB	Global reset pin. Active low to enter reset state. Suggest to connecting with an RC reset circuit for stability. Normally pull high(R=10K Ω C=1 μ F)	
45	NC	Not Connect	
46	VCOM	External VCOM DC input	
47	DITHB	Dithering setting. DITH="H" Disable internal dithering function DITH="L" Enable internal dithering function	
48	GND	Power Ground	
49	NC	Not Connect	
50	NC	Not Connect	

Note 1: SHLR: left or right setting

UPDN: up or down setting

SHLR	UPDN	Data Shifting
DVDD	GND	Left→Right, Up→Down(Default)
GND	GND	Right→Left, Up→Down
DVDD	DVDD	Left→right, Down→Up
GND	DVDD	Right→Left, Down→Up

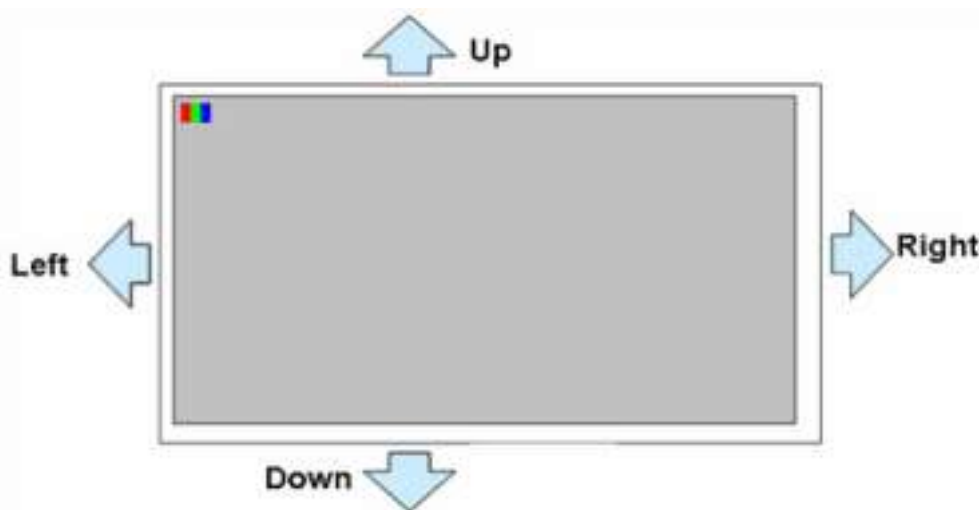

5.2 Back-Light Unit

The backlight system is an edge-lighting type with 3C10P=30 LED.



The characteristics of the LED are shown in the following tables.

Item	Symbol	Min	Typ	Max	Unit	Note
LED current	IL	270	300	330	mA	
LED voltage	VL	9.0	9.6	10.5	V	
Operating LED life time	Hr	30000	--	--	Hour	(1)

Note (1) LED life time (Hr) can be defined as the time in which it continues to operate under the condition: $T_a=25\pm 3\text{ }^\circ\text{C}$, typical IL value indicated in the above table and the $f_L=50\text{kHz}$ until the brightness becomes less than 50%.

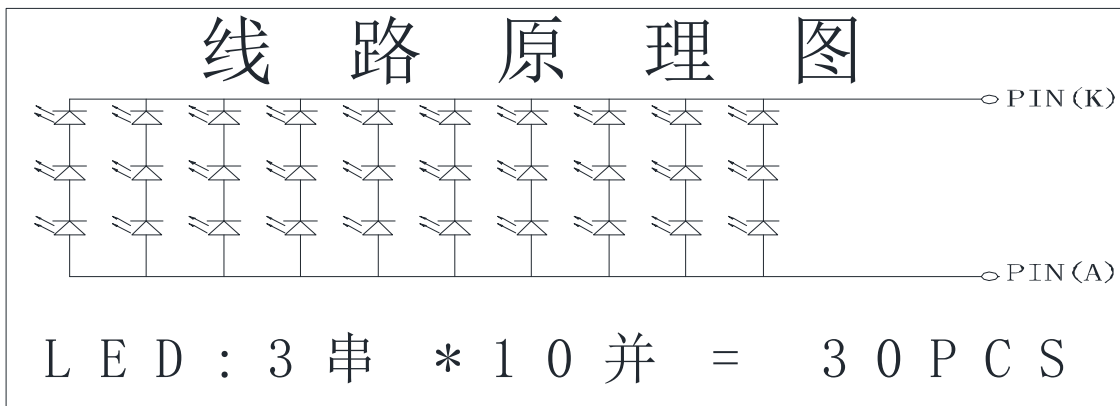

6.0 ELECTRICAL CHARACTERISTICS

6.1 TFT LCD Module

Item	Symbol	Min.	Typ.	Max.	Unit	Note
Common Voltage	VCOM	2.60	(3.60)	4.60	V	Note 1
Power supply voltage	DVDD	3.0	3.3	3.6	V	
Analog Supply Voltage	AVDD	10.2	10.4	10.60	V	调整对比度, 调大颜色变深, 调小颜色变浅
Gate On Voltage	VGH	--	15.0	--	V	
Gate Off Voltage	VGL	--	-10.0	--	V	
Operation frequency	FCKV	--	--	200	KHz	

Note 1: Please adjust VCOM to make the flicker level be minimum. Typ VCOM 电压值

只做参考, 具体以实际效果为准 (根据FLICKER 状态可调整)

Note 2: Be sure to apply DV DD and V GL to the LCD first, and then apply V GH .

Note 3: DV DD setting should match the signals output voltage (refer to Note 3) of customer's system board.

Note 4: DCLK,HS,VS,RESET,U/D, L/R,DE,R0~R7,G0~G7,B0~B7,MODE,DITHB.

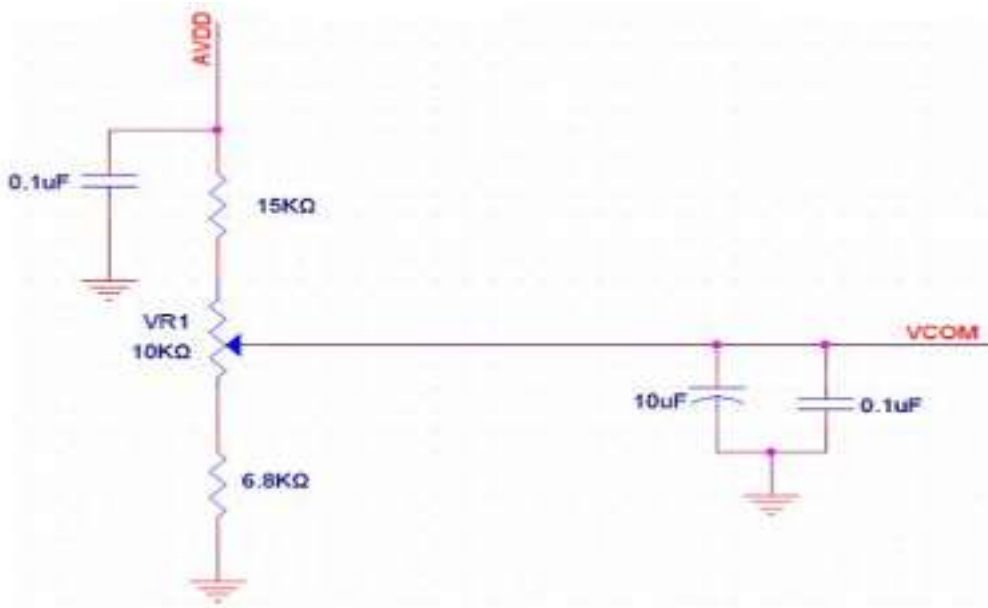

6.2 Current Consumption

Item	Symbol	Min.	Typ.	Max.	Unit	Note
Current for Driver	IGH	-	0.2	1.0	mA	VGH=15.0V
	IGL	-	0.5	1.0	mA	VGL=-10.0V
	IDVDD	-	4.0	10	mA	DVDD=3.3V
	IAVDD	-	20	50	mA	AVDD=-10.4V

6.3 Power Sequence

Power on:

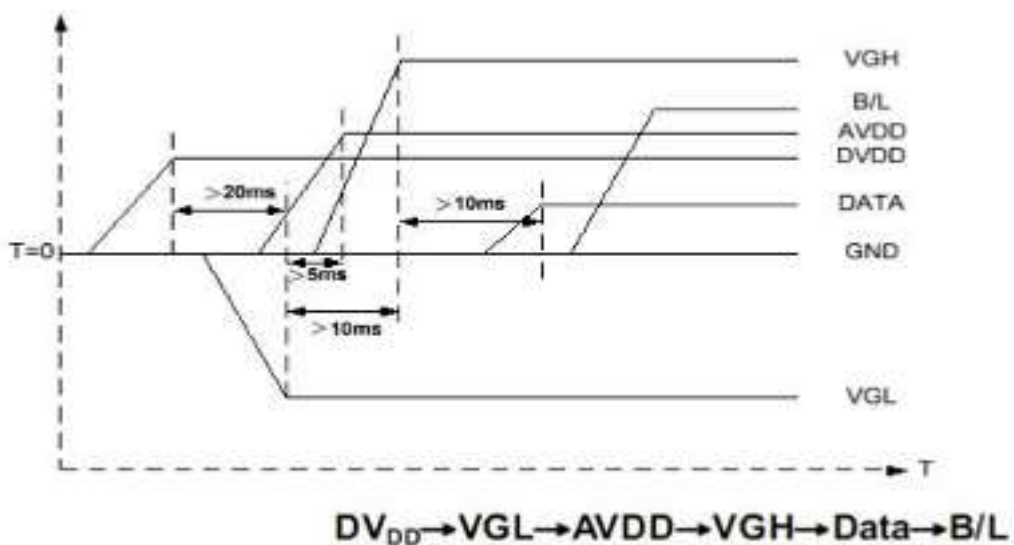

Power off:

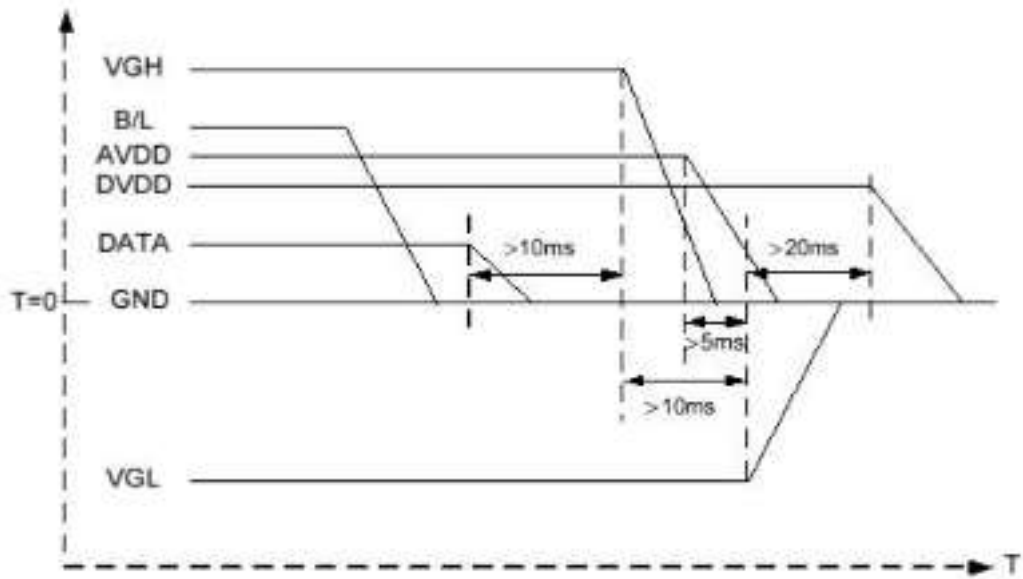

B/L→Data→VGH→AVDD→VGL→DV_{DD}

Note: Data include R0~R7, B0~B7, G0~G7, U/D, L/R, DCLK, HS,VS,DE.

6.4 Timing Characteristics

6.4.1 AC Electrical Characteristics

Item	Symbol	Values			Unit	Remark
		Min.	Typ.	Max.		
HS setup time	T _{hst}	8	-	-	ns	
HS hold time	T _{hhd}	8	-	-	ns	
VS setup time	T _{vst}	8	-	-	ns	
VS hold time	T _{vhd}	8	-	-	ns	
Data setup time	T _{dsu}	8	-	-	ns	
Data hole time	T _{dhd}	8	-	-	ns	
DE setup time	T _{esu}	8	-	-	ns	
DE hole time	T _{ehd}	8	-	-	ns	
DV _{DD} Power On Slew rate	T _{POR}	-	-	20	ms	From 0 to 90% DV _{DD}
RESET pulse width	T _{Rst}	1	-	-	ms	
DCLK cycle time	T _{coh}	20	-	-	ns	
DCLK pulse duty	T _{own}	40	50	60	%	



6.4.2 Input Clock and Data Timing Diagram

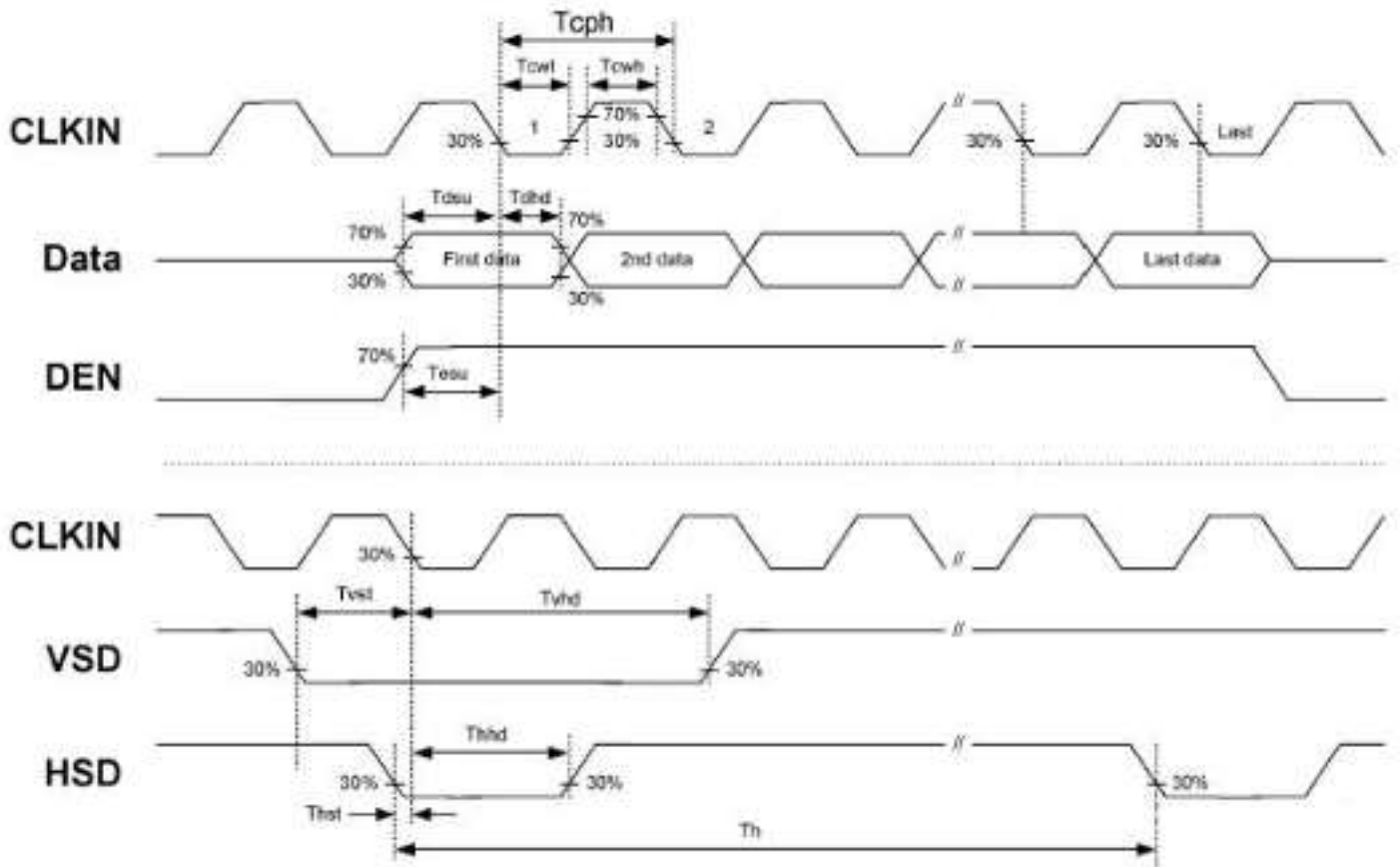

6.5 Timing

Item	Symbol	Values			Unit	Remark
		Min.	Typ.	Max.		
Horizontal Display Area	thd	-	800	-	DCLK	
DCLK Frequency	fclk	26.4	33.3	46.8	MHz	
One Horizontal Line	th	862	1056	1200	DCLK	
HS pulse width	thpw	1	-	40	DCLK	
HS Blanking	thb	46	46	46	DCLK	
HS Front Porch	thfp	16	210	354	DCLK	



Item	Symbol	Values			Unit	Remark
		Min.	Typ.	Max.		
Vertical Display Area	tvd	-	480	-	TH	
VS period time	tv	510	525	650	TH	
VS pulse width	tvpw	1	-	20	TH	
VS Blanking	tvb	23	23	23	TH	
VS Front Porch	tvfp	7	22	147	TH	

6.6 Data Input Format

Horizontal input timing diagram:



Vertical input timing diagram:

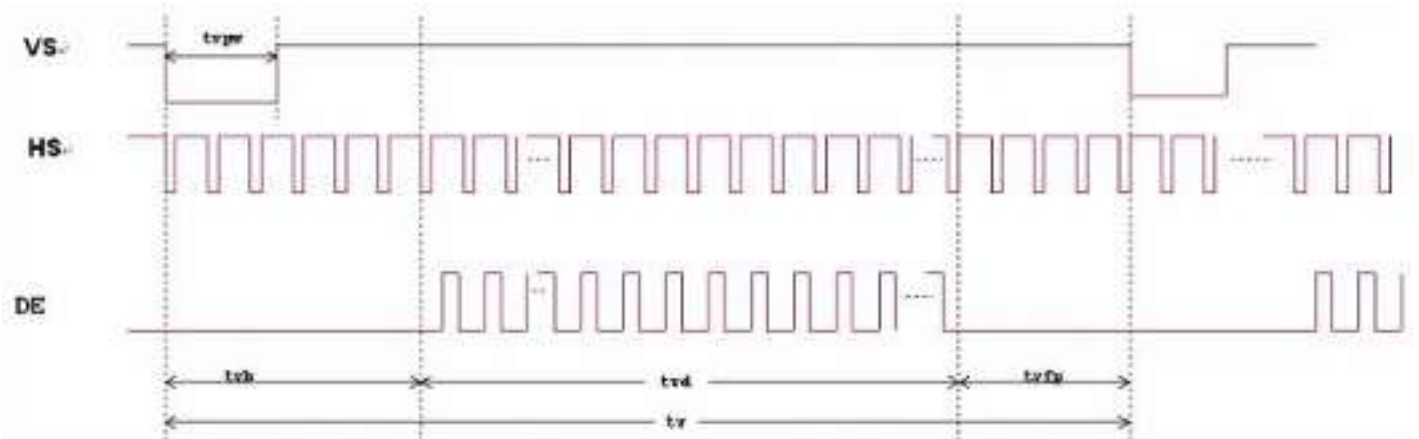



7.0 RELIABILITY TEST ITEMS

No.	Test Item	Conditions	Note
1	High Temperature Storage	Ta=+70°C, 24hrs	
2	Low Temperature Storage	Ta=-30°C, 24hrs	
3	High Temperature Operation	Ta=+60°C, 24hrs	
4	Low Temperature Operation	Ta=-20°C, 24hrs	
5	High Temperature and High Humidity(operation)	Ta=+60°C, 90%RH 24hrs	
6	Thermal cycling Test	-30°C/30 min ~ +80°C/30 min for a total 24 cycles, Start with cold temperature and end with high temperature.	
7	Vibration Test (Non-operation)	<ul style="list-style-type: none"> ● Frequency range:8~33.3Hz ● Stoke: 1.3 mm ● Vibration: sinusoidal wave, perpendicular axis(both x, z axis: 2hrs ,y axis: 4hrs). ● Sweep: 2.9G,33.3 Hz -400 Hz ● Cycle time: 15 min 	
8	Shock Test (Non-operation)	<ul style="list-style-type: none"> ● Shock level: 980m/s 2 (equal to 100G). ● Waveform: half sinusoidal wave,6ms. ● Number of shocks: ±X,±Y,±Z axes for a total of six shock inputs. 	
9	ESD Test	150pF, 330Ω, ±8kV&±4kV air& contact test	1
		200pF, 0Ω, ±200V contact test	2

Note 1: LCD glass and metal bezel

Note 2: IF connector pins

Note 3: Operation with test pattern sustained for 4hrs, then change to gray pattern immediately.

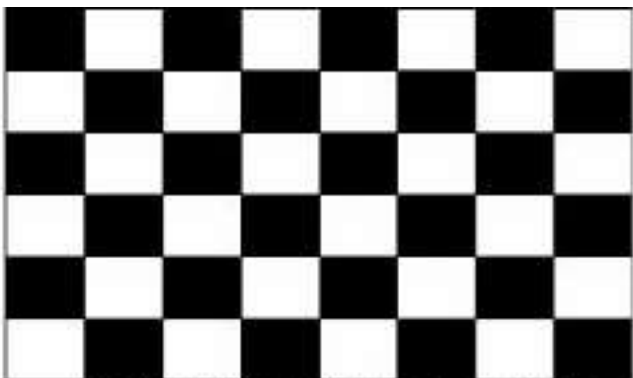

(a) Test Pattern (chess board Pattern)

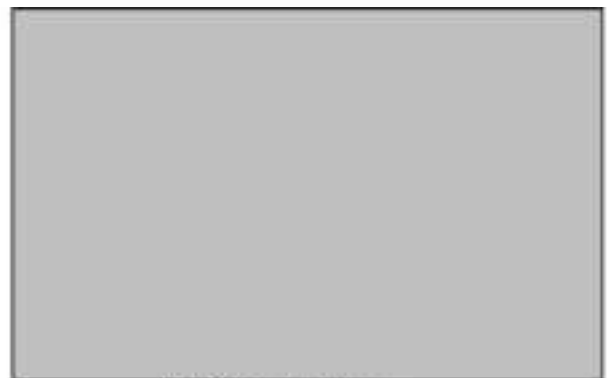

(b) Gray Pattern



8.0 OUTLINE DIMENSION

DIMENSION RANGE	
尺寸范围	
TOLERENCE	公差
0	0
1.5	1.5
2	2
3	3
4	4
5	5
6	6
7	7
8	8
9	9
10	10
15	15
20	20
30	30
40	40
50	50
60	60
80	80
100	100
150	150
200	200
300	300
400	400
500	500
600	600
800	800
1000	1000

Customer Name: 客户名称

ROHS

Approval Date: 承认日期

Approved by: 承认

Please Confirm This Drawing 请退回此图

Part No. 料号

REV 版本

CMI 7.0TN 800*480

模组图

主要材料表

10	PKG	1
9	Bezel	1
8	Reflector film	1
7	Prism film (upper)	1
6	Prism film (lower)	1
5	Diffuser film	1
4	SMT LED (white)	30
3	PPC	1
2	Light guide	1
1	Plastic housing	1

NO. TITLE (名称) QTY MATERIAL (材质)

APPROVED BY 核准 审核 繪圖

APPROVED BY 核准 审核 繪圖

APPROVED BY 核准 审核 繪圖

模组的尺寸标注:

- ★ 164.90 ± 0.20 (Outline)
- 157.00 ± 0.20 (Bezel Open)
- 155.89 ± 0.20 (UP POL)
- 154.08 (Active Area)
- (83.74)
- ★ 100.00 ± 0.20 (Outline)
- (89.33 ± 0.20 (Bezel Open))
- (88.49 ± 0.20 (UP POL))
- 85.92 (Active Area)
- (48.08)
- TTT 7.0" 上 FEMV片
- 800(DIAG) * 480 (DHS)
- 6:00 O'clock
- A.A.(ACTIVE AREA) Center)
- (80.00 ± 1.00)
- Pin6
- 总厚度: 0.30 ± 0.03mm
- 反面补强+PPC

测试点位置图

光源

线路原理图

LED: 3串*10并= 30PCS

Notes:

1. RoHS must be complied.
2. Modification rev number
3. Draft angle 1.5°
4. () reference dimension, \square critical dimension $\neq 0$
5. All radii without dimension R0.3, Unspecified Tolerances is:

Electrical-Optical Characteristics (Ta=25° C):

Item	Symbol	Unit	Test Condition
亮度 (Average)	Lv	cd/m²	1000 Hz, 100%
亮度 (Rms)	Lr	cd/m²	1000 Hz, 100%
平均亮度	Avg	cd/m²	75%, 0.33
色坐标 X	X		0.26, 0.30
色坐标 Y	Y		0.27, 0.30
功率耗散	Pd	W	5.0, 10.0, 15.0
正向电压	Vf	V	3.0, 3.5, 4.0
反向电压	Vr	V	5.0, 10.0, 15.0
反向电流	Ir	mA	1.0, 2.0, 3.0
工作温度	Tj	°C	0, 25, 50, 70, 100
贮存温度	Tstg	°C	-30, 0, 70, 100

DETAIL A(5:1)



9.0 BOM LIST

(TBD)

10.0 LOT MARK

10.1 Location of Lot Mark

- (1) Location: The label is attached to the backside of the LCD module.
- (2) Detail of the Mark: as attached below.
- (3) This is subject to change without prior notice.

(TBD)

11 0 PACKAGE SPECIFICATION



11.1 Packing form

LCM Model	LCM Qty. in the box	Inner Box Size (mm)	Note
HG070WX026	60 pcs/box	460±5 x 360±5 x 175±5	

11.2 Packing assembly drawings

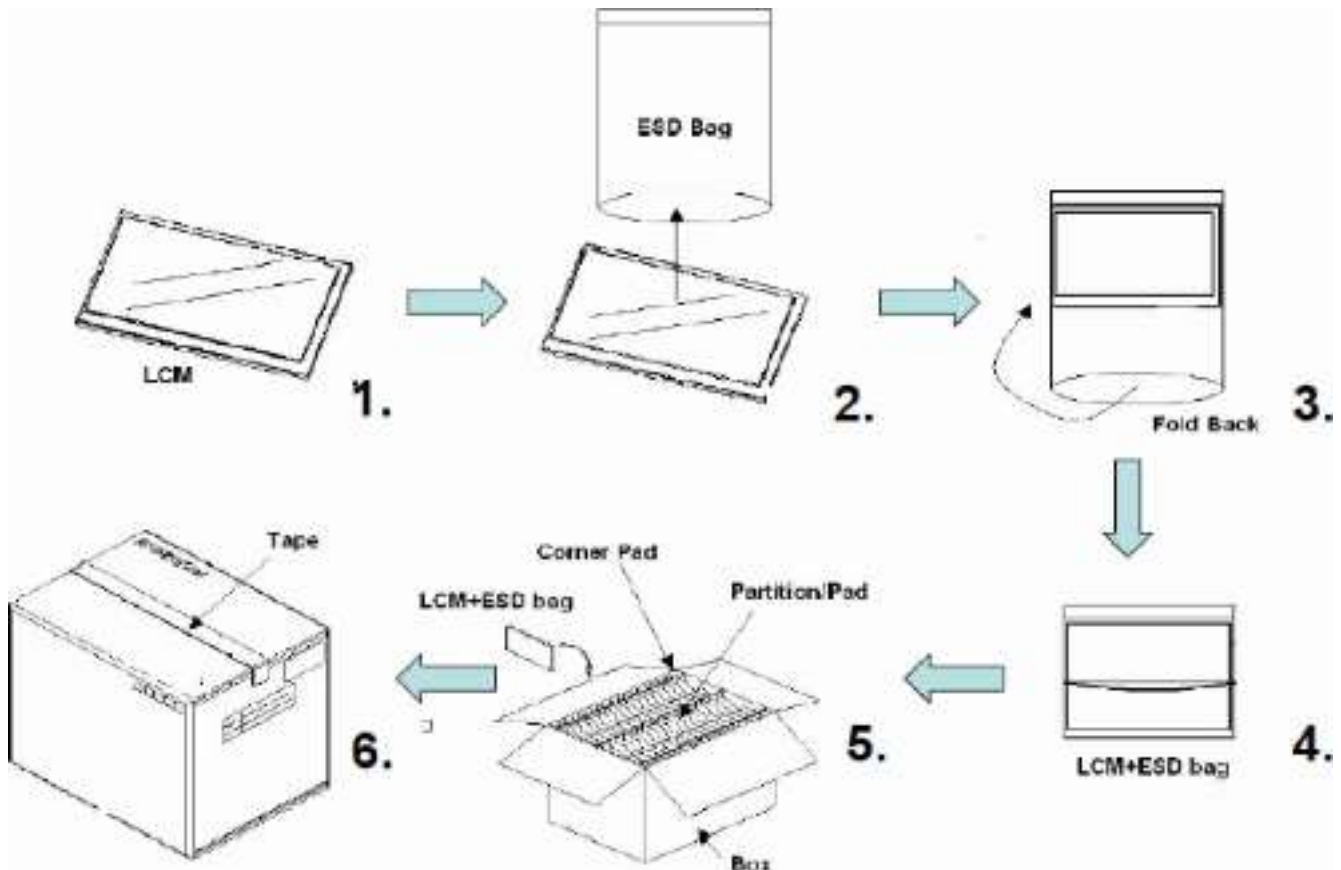

Items	Material	Notice
Box	Corrugated Paper Board	AB Flute
Partition/Pad	Corrugated Paper Board	B Flute
Corner Pad	Corrugated Paper Board	AB Flute
ESD bag	PE	

12.0 GENERAL PRECAUTION



12.1 Use Restriction

This product is not authorized for use in life supporting systems, aircraft navigation control systems, military systems and any other application where performance failure could be life-threatening or otherwise catastrophic.

12.2 Assembly Precaution

- 12.2.1 Please use the mounting hole on the module side in installing and do not bending or wrenching LCD in assembling. And please do not drop, bend or twist LCD module in handling.
- 12.2.2. Please design display housing in accordance with the following guide lines.
 - 12.2.2.1 Housing case must be destined carefully so as not to put stresses on LCD all sides and not to wrench module. The stresses may cause non-uniformity even if there is no non-uniformity statically.
 - 12.2.2.2 Keep sufficient clearance between LCD module back surface and housing when the LCD module is mounted. The clearance in the design is recommended taking into account the tolerance of LCD module thickness and mounting structure height on the housing.
- 12.2.3 Please do not push or scratch LCD panel surface with any-thing hard. And do not soil LCD panel surface by touching with bare hands.(Polarizer film, surface of LCD panel is easy to be flawed.)
- 12.2.4 Please do not press any parts on the rear side such as source IC, gate IC, and FPC during handling LCD module, If pressing rear part is unavoidable, handle the LCD module with care not to damage them.
- 12.2.5 Please wipe out LCD panel surface with absorbent cotton or soft cloth in case of it being soiled.
- 12.2.6 Please wipe out drops of adhesives like saliva and water on LCD panel surface immediately. They might damage to cause panel surface variation and color change.
- 12.2.7 Please do not take a LCD module to pieces and reconstruct it. Resolving and reconstructing modules may cause them not to work well.

12.3 Disassembling or Modification

Do not disassemble or modify the module. It may damage sensitive parts inside LCD module, and may cause scratches or dust on the display. Century does not warrant the module, if customers disassemble or modify the module.

12.4 Breakage of LCD Panel

- 12.4.1.If LCD panel is broken and liquid crystal spills out, do not ingest or inhale liquid crystal, and do not contact liquid crystal with skin.
- 12.4.2. If liquid crystal contacts mouth or eyes, rinse out with water immediately.
- 12.4.3. If liquid crystal contacts skin or cloths, wash it off immediately with alcohol and rinse thoroughly with water.
- 12.4.4. Handle carefully with chips of glass that may cause injury, when the glass is broken.

12.5 Absolute Maximum Ratings and Power Protection Circuit



- 12.5.1. Do not exceed the absolute maximum rating values, such as the supply voltage variation, input voltage variation, variation in parts' parameters, environmental temperature, etc., otherwise LCD module may be damaged.
- 12.5.2. Please do not leave LCD module in the environment of high humidity and high temperature for a long time.
- 12.5.3. It's recommended to employ protection circuit for power supply.

12.6 Operation

- 12.6.1 Do not touch, push or rub the polarizer with anything harder than HB pencil lead.
- 12.6.2 Use fingerstalls of soft gloves in order to keep clean display quality, when persons handle the LCD module for incoming inspection or assembly.
- 12.6.3 When the surface is dusty, please wipe gently with absorbent cotton or other soft material.
- 12.6.4 Wipe off saliva or water drops as soon as possible. If saliva or water drops contact with polarizer for a long time, they may causes deformation or color fading.
- 12.6.5 When cleaning the adhesives, please use absorbent cotton wetted with a little petroleum benzene or other adequate solvent.

12.7 Static Electricity

- 12.7.1 Protection film must remove very slowly from the surface of LCD module to prevent from electrostatic occurrence.
- 12.7.2. Because LCD module use CMOS-IC on circuit board and TFT-LCD panel, it is very weak to electrostatic discharge. Please be careful with electrostatic discharge.
- 12.7.3 Persons who handle the module should be grounded through adequate methods.

12.8 Disposal

When disposing LCD module, obey the local environmental regulations.

12.9 Others

- 12.9.1 A strong incident light into LCD panel might cause display characteristics' changing inferior because of Polarizer film, color filter, and other materials becoming inferior. Please do not expose LCD module direct sunlight Land Strong UV rays.
- 12.9.2 Please pay attention to a panel side of LCD module not to contact with other materials in pressing it alone.
- 12.9.3 For the packaging box, please pay attention to the followings:
 - 12.9.3.1 Packaging box and inner case for LCD are designed to protect the LCDs from the damage or scratching during transportation. Please do not open except picking LCDs up from the box.
 - 12.9.3.2 Please do not pile them up more than 6 boxes(They are not designed so) And please do not turn over.
 - 12.9.3.3 Please handle packaging box with care not to give them sudden shock and vibrations. And also please do not throw them up.
 - 12.9.3.4 Packing box and inner case for LCDs are made of cardboard, So please pay attention not to get them wet(Such like keeping them in high humidity or wet place can occur getting them wet.)